



BACKLASH FREE ELASTOMER COUPLINGS SERVOMAX[®] / ECOLIGHT[®] 0.5 - 25,000 Nm



GENERAL INFORMATION ABOUT R+W ELASTOMER COUPLINGS:



SERVICE LIFE

When properly selected, handled, and installed, these couplings are maintenance free with infinite service life.

ATEX (Optional)

For use in hazardous zones 1/21 and 2/22, the elastomer coupling has been authorized under directive 94/9/EG and is available with certification.

SPECIAL SOLUTIONS

Various materials, tolerances, dimensions and performance ratings available for custom applications on request.

FIT CLEARANCE

Overall shaft / hub clearance of 0.01 - 0.05 mm

FEATURES





Elastomer is press fit for zero backlash; standard versions are electrically isolating.



BACKLASH FREE ELASTOMER COUPLINGS

SERVOMAX® AND ECOLIGHT®

0.5 - 25,000 Nm

MODEL		FEATURES	
EK1		with keyway connection from 0.5 - 25,000 Nm <ul style="list-style-type: none">▶ press fit design▶ readily modified for custom dimensions	Page 74-75
EK2		with clamping hub from 6 - 2,150 Nm <ul style="list-style-type: none">▶ high concentricity▶ backlash free▶ easy mounting	Page 76
EKL		with clamping hub from 0.5 - 2,150 Nm <ul style="list-style-type: none">▶ compact design▶ low moment of inertia▶ easy mounting	Page 77
EKH		with split clamping hub from 4 - 25,000 Nm <ul style="list-style-type: none">▶ for lateral installation▶ allows for pre-aligned shafts▶ easy mounting	Page 78-79
EK6		with conical clamping ring from 4 - 25,000 Nm <ul style="list-style-type: none">▶ high concentricity▶ high clamping pressure▶ self centering hub design▶ allows for axial installation	Page 80-81

MODEL

FEATURES

SP6



**for high speed spindle applications
from 60 - 1,350 Nm**

Page 82

- ▶ very high precision
- ▶ very high concentricity
- ▶ high clamping force
- ▶ symmetrically machined hubs

EK7



**with expanding shaft
from 2 - 2,150 Nm**

Page 83

- ▶ for hollow shaft mounting
- ▶ expanding shaft through axial tightening
- ▶ short body length after installation

EKZ



**intermediate spacer
from 2 - 2,150 Nm**

Page 84

- ▶ high lateral misalignment
- ▶ easy to mount
- ▶ vibration damping

EK4



**for tapered shafts
from 6 - 400 Nm**

Page 85

- ▶ for tapered shafts such as Fancu motors
- ▶ easy mounting
- ▶ axial installation onto tapered shaft

TX1



**with keyway connection
from 0.5 - 810 Nm**

Page 86-87

- ▶ corrosion proof
- ▶ low cost
- ▶ light weight

GENERAL INFORMATION

R+W ELASTOMER COUPLINGS

AXES OF MISALIGNMENT

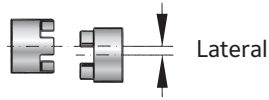

Lateral

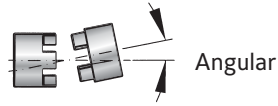

Angular

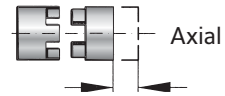

Axial

FUNCTION

The equalizing element of the EK coupling is the elastomer insert. It transmits torque without backlash or vibration. The elastomer insert defines the characteristics of the entire drive system.

Backlash is eliminated by the press fit of the elastomer into the hubs. Through variation of the Shore hardness of the elastomer insert, the coupling system can be optimized for the ideal torsional characteristics.

SIZES 2 - 800



A

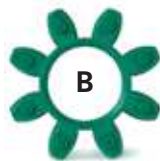

B



C



D



E

Shore hardness 98 A

Shore hardness 64 Sh D

Shore hardness 80 Sh A

Shore hardness 65 Sh D

Shore hardness 64 Sh D

SIZES 2500 - 9500

THE COUPLING INCLUDES 5X ELASTOMER SEGMENTS

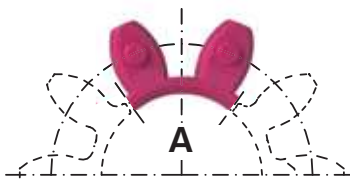

A

Shore hardness 98 A

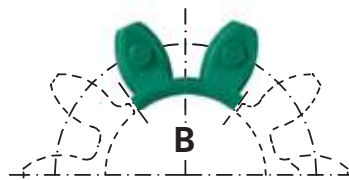

B

Shore hardness 64 Sh D

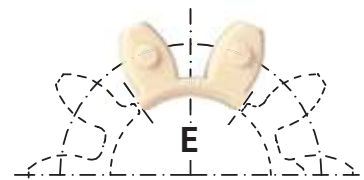

E

Shore hardness 64 Sh D

DESCRIPTION OF THE ELASTOMER INSERTS

Type	Shore hardness	Color	Material	Relative damping (Ψ)	Temperature range	Features
A	98 Sh A	red	TPU	0.4 - 0.5	-30°C to +100°C	high damping
B	64 Sh D	green	TPU	0.3 - 0.45	-30°C to +120°C	high torsional stiffness
C	80 Sh A	yellow	TPU	0.3 - 0.4	-30°C to +100°C	very high damping
D*	65 Sh D	black	TPU	0.3 - 0.45	-10°C to + 70°C	electrically conductive
E	64 Sh D	beige	Hytrel	0.3 - 0.45	-50°C to +150°C	temperature resistant

* The electrical conductivity of the elastomer material is to prevent the electrostatic charging of the elastomer coupling system, to reduce the risk of sparking in operation. ATEX technical data is available upon request.

The values of the relative damping were determined at 10 Hz and +20° C.

SIZES EK

SIZE		2			5			10			20			60			150		
Type (Elastomer insert)		A	B	C	A	B	C	A	B	C	A	B	C	A	B	C	A	B	C
Static torsional stiffness (Nm/rad)	C_T	50	115	17	150	350	53	260	600	90	1140	2500	520	3290	9750	1400	4970	10600	2000
Dynamic torsional stiffness (Nm/rad)	C_{Tdyn}	100	230	35	300	700	106	541	1650	224	2540	4440	876	7940	11900	2072	13400	29300	3590
Lateral (mm)	Max. values	0.08	0.06	0.2	0.08	0.06	0.2	0.1	0.08	0.22	0.1	0.08	0.25	0.12	0.1	0.25	0.15	0.12	0.3
Angular (Degree)		1	0.8	1.2	1	0.8	1.2	1	0.8	1.2	1	0.8	1.2	1	0.8	1.2	1	0.8	1.2
Axial (mm)		±1			±1			±1			±1.5			±1.5			±1.8		

SIZE		300			450			800			2500		4500		9500	
Type (Elastomer insert)		A	B	C	A	B	C	A	B	C	A	B	A	B	A	B
Static torsional stiffness (Nm/rad)	C_T	12400	18000	3000	15100	27000	4120	41300	66080	10320	87600	109000	167000	372000	590000	670000
Dynamic torsional stiffness (Nm/rad)	C_{Tdyn}	23700	40400	6090	55400	81200	11600	82600	180150	28600	175000	216000	337000	743000	1180000	1340000
Lateral (mm)	Max. values	0.18	0.14	0.35	0.2	0.18	0.35	0.25	0.2	0.4	0.5	0.3	0.5	0.3	0.6	0.4
Angular (Degree)		1	0.8	1.2	1	0.8	1.2	1	0.8	1.2	1.5	1	1.5	1	1.5	1
Axial (mm)		±2			±2			±2			±3		±3		±4	

Static torsional stiffness at 50% T_{KN}

Dynamic torsional stiffness at T_{KN}

EK1

WITH KEYWAY CONNECTION

0.5 - 2,150 Nm



PROPERTIES

FEATURES

- ▶ press fit design
- ▶ readily modified for custom dimensions
- ▶ low backlash (keyway)

MATERIAL

- ▶ **Hubs:** up to size 450 high strength aluminum; size 800 steel
- ▶ **Elastomer:** wear resistant thermally stable TPU

DESIGN

Two concentrically machined hubs with curved jaws, keyways, and set screws.

Optional:
Conical bores for Fanuc motors and other tapered shafts available.

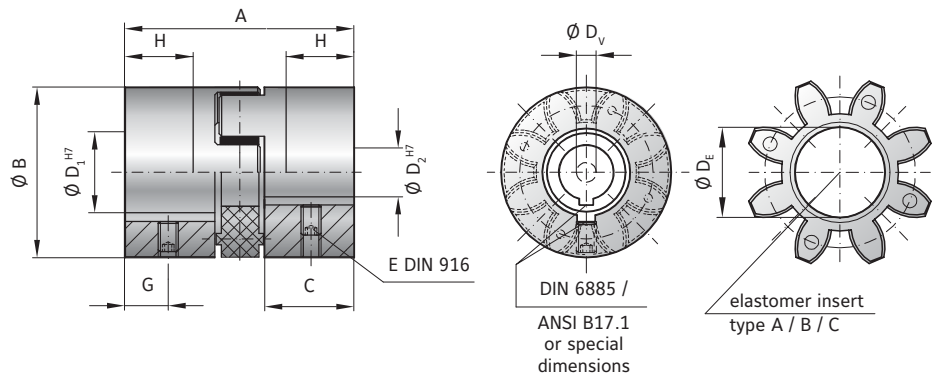

MODEL EK1

SIZE	2			5			10			20			60			150			300			450			800		
Type (Elastomer insert)	A	B	C	A	B	C	A	B	C	A	B	C	A	B	C	A	B	C	A	B	C	A	B	C	A	B	C
Rated torque (Nm) T_{KN}	2	2.4	0.5	9	12	2	12.5	16	4	17	21	6	60	75	20	160	200	42	325	405	84	530	660	95	950	1100	240
Max. torque (Nm) T_{Kmax}	4	4.8	1	18	24	4	25	32	6	34	42	12	120	150	35	320	400	85	650	810	170	1060	1350	190	1900	2150	400
Overall length (mm) A	20			34			35			66			78			90			114			126			162		
Outside diameter (mm) B/B ₁	15			25			32			42			56			66.5			82			102			136.5		
Mounting length (mm) C	6.5			12			12			25			30			35			45			50			65		
Inside diameter (pilot bored) (mm) D _V	3			4			6			7			9			14			16			22			29		
Inside diameter range H7 (mm) D _{1/2}	3 - 9			6 - 15			6 - 18			8 - 25			12 - 32			19 - 38			20 - 45			28 - 60			32 - 80		
Inside diameter of elastomer (mm) D _E	6.2			10.2			14.2			19.2			26.2			29.2			36.2			46.2			60.5		
Set screws (DIN 916) E	see table (depending on bore Ø)**																										
Distance (mm) G	3			5			6			9			11			12			15			17			30		
Possible shortening length (mm) H	4			6			6			19			22			26			32			37			43		
Moment of inertia per hub (10 ⁻³ kgm ²) J ₁ /J ₂	0.0001			0.001			0.003			0.02			0.06			0.1			0.4			1.1			12		
Approx. weight (kg)	0.008			0.03			0.08			0.15			0.35			0.6			1.1			1.7			11		
Speed standard (min ⁻¹)	15,000			15,000			13,000			12,500			11,000			10,000			9,000			8,000			4,000		
Speed balanced (10 ³ min ⁻¹)	60	67	45	57	65	43	53	63	40	45	60	35	31	31	25	22	26	18	22	26	16	16	17	12	13	13	8

For information on shaft misalignment, torsional stiffness, and other details about the elastomer inserts see pages 72 + 73.

** set screw size							
D ₁ /D ₂	- Ø 10	Ø 10.1 - 12	Ø 12.1 - 30	Ø 30.1 - 60	Ø 60.1 - 95	Ø 95.1 - 130	Ø 130.1 - 170
E	M3	M4	M5	M8	M10	M12	M16

EK1

WITH KEYWAY CONNECTION

1,950 – 25,000 Nm



PROPERTIES

FEATURES

- ▶ press fit design
- ▶ readily modified for custom dimensions
- ▶ low backlash (keyway)

DESIGN

Two concentrically machined hubs with curved jaws, keyways, and set screws. Elastomer insert consist of 5 segments.

MATERIAL

- ▶ **Hubs:** GGG40
- ▶ **Elastomer:** wear resistant thermally stable TPU

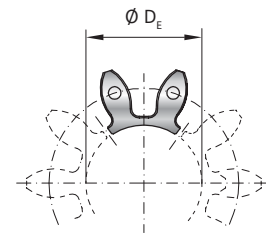
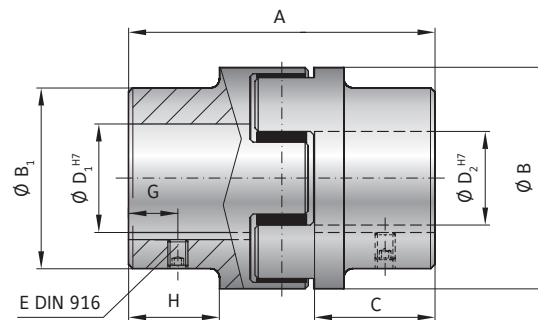

elastomer insert type A / B

MODEL EK1

SIZE		2500		4500		9500	
Type (Elastomer insert)		A	B	A	B	A	B
Rated torque (Nm)	T_{KN}	1950	2450	5000	6200	10000	12500
Max. torque (Nm)	T_{Kmax}	3900	4900	10000	12400	20000	25000
Overall length (mm)	A	213		272		341	
Outside diameter (mm)	B/B_1	160 / 154		225 / 190		290 / 240	
Mounting length (mm)	C	88		113		142	
Inside diameter (pilot bored) (mm)	D_v	30		40		50	
Inside diameter range H7 (mm)	$D_{1/2}$	30 - 95		40 - 130		50 - 170	
Inside diameter of elastomer (mm)	D_E	80		111		145	
Set screws (DIN 916)	E	see table (depending on bore \emptyset)**					
Distance (mm)	G	25		30		40	
Possible shortening length (mm)	H	69		89		110	
Moment of inertia per hub (10^{-3} kgm^2)	J_1/J_2	40		147		480	
Approx. weight (kg)		12.5		25		53	
Speed standard (min^{-1})		3,500		3,000		2,000	
Speed balanced (10^3 min^{-1})		10	10	8	8	6.5	6.5

For information on shaft misalignment, torsional stiffness, and other details about the elastomer inserts see pages 72 + 73.

ORDERING EXAMPLE	EK1	2500	A	50.8	80	XX
Model	●					Special designation only (e.g. special bore tolerance).
Size		●				
Elastomer insert type			●			
Bore D1 H7				●		
Bore D2 H7					●	

For custom features place an XX at the end of the part number and describe the special requirements (e.g. EK1 / 2500 / A / 50.8 / 80 / XX; XX=stainless steel)

EK2

WITH CLAMPING HUB 6 - 2,150 Nm

PROPERTIES



FEATURES

- ▶ easy mounting
- ▶ highly concentric assembly
- ▶ vibration damping

MATERIAL

- ▶ **Hubs:** up to size 450 high strength aluminum; size 800 steel
- ▶ **Elastomer:** wear resistant thermally stable TPU

DESIGN

Two concentrically machined hubs with curved jaws and clamping screws.

ORDERING EXAMPLE

see page 73

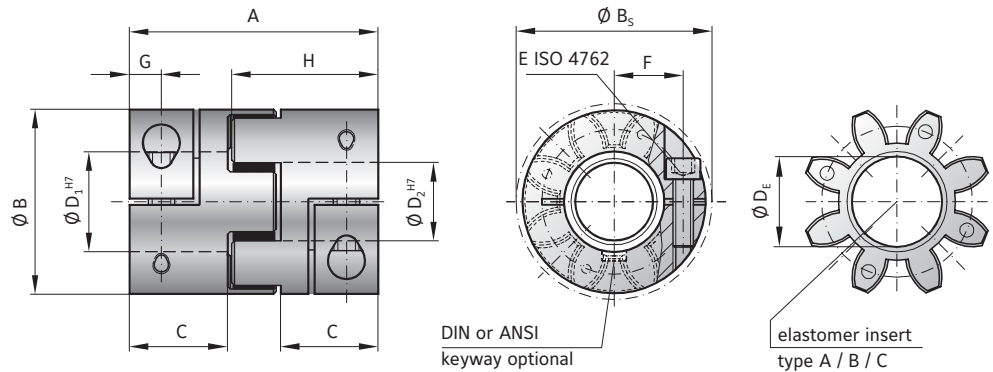

MODEL EK2

SIZE	20			60			150			300			450			800					
Type (Elastomer insert)	A	B	C	A	B	C	A	B	C	A	B	C	A	B	C	A	B	C			
Rated torque (Nm) T_{KN}	17	21	6	60	75	20	160	200	42	325	405	84	530	660	95	950	1100	240			
Max. torque* (Nm) T_{Kmax}	34	42	12	120	150	35	320	400	85	650	810	170	1060	1350	190	1900	2150	400			
Overall length (mm)	A			78			90			114			126			162					
Outside diameter (mm)	B			56			66.5			82			102			136.5					
Outside diameter with screw head (mm)	B_5			57			68			85			105			139					
Mounting length (mm)	C			30			35			45			50			65					
Inside diameter range H7 (mm)	$D_{1/2}$			8 - 25			12 - 32			19 - 36			20 - 45			28 - 60			35 - 80		
Inside diameter of elastomer (mm)	D_E			19.2			26.2			29.2			36.2			46.2			60.5		
Clamping screw (ISO 4762)	E			M5			M6			M8			M10			M12			M16		
Tightening torque of the clamping screw (Nm)	E			8			15			35			70			120			290		
Distance between centers (mm)	F			15.5			21			24			29			38			50.5		
Distance (mm)	G			8.5			10			12			15			17.5			23		
Hub length (mm)	H			39			46			52.5			66			73			93.5		
Moment of inertia per hub (10^{-3} kgm^2) J_1/J_2	E			0.016			0.05			0.13			0.4			0.9			9.5		
Approx. weight (kg)	E			0.15			0.35			0.6			1.1			1.7			10		
Speed standard (min^{-1})	E			12,500			11,000			10,000			9,000			8,000			4,000		
Speed balanced (10^3 min^{-1})	45	60	35	31	31	25	22	26	18	22	26	16	16	17	12	13	13	8			

For information on shaft misalignment, torsional stiffness, and other details about the elastomer inserts see pages 72 + 73.

* Maximum transmittable torque of the clamping hub depends on the bore diameter

Size	Ø 8	Ø 16	Ø 19	Ø 25	Ø 30	Ø 32	Ø 35	Ø 45	Ø 50	Ø 55	Ø 60	Ø 65	Ø 70	Ø 75	Ø 80
20	20	35	45	60											
60		50	80	100	110	120									
150			120	160	180	200	220								
300			200	230	300	350	380	420							
450					420	480	510	600	660	750	850				
800							700	750	800	835	865	900	925	950	1,000

Higher torque possible with keyways

COMPACT VERSION WITH CLAMPING HUB 0.5 - 2,150 Nm



PROPERTIES

FEATURES

- ▶ short overall length
- ▶ easy mounting
- ▶ vibration damping

MATERIAL

- ▶ **Hubs:** up to size 450 high strength aluminum; size 800 steel
- ▶ **Elastomer:** wear resistant thermally stable TPU

DESIGN

Two concentrically machined hubs with curved jaws and clamping screws.

ORDERING EXAMPLE

see page 73

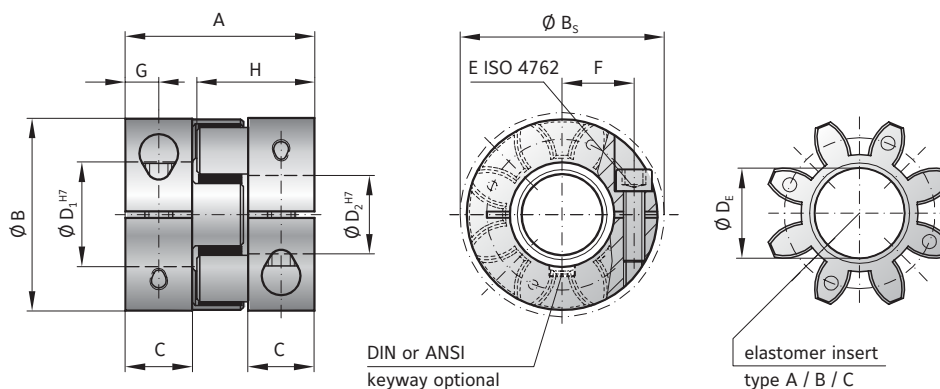

MODEL EKL

SIZE	2			5			10			20			60			150			300			450			800					
Type (Elastomer insert)	A	B	C	A	B	C	A	B	C	A	B	C	A	B	C	A	B	C	A	B	C	A	B	C	A	B	C			
Rated torque (Nm) T_{KN}	2	2.4	0.5	9	12	2	12.5	16	4	17	21	6	60	75	20	160	200	42	325	405	84	530	660	95	950	1100	240			
Max. torque* (Nm) T_{Kmax}	4	4.8	1	18	24	4	25	32	6	34	42	12	120	150	35	320	400	85	650	810	170	1060	1350	190	1900	2150	400			
Overall length (mm)	A			20			26			32			50			58			62			86			94			123		
Outside diameter (mm)	B			16			25			32			42			56			66.5			82			102			136.5		
Outside diameter with screw head (mm)	B_s			17			25			32			44.5			57			68			85			105			139		
Mounting length (mm)	C			6			8			10.3			17			20			21			31			34			46		
Inside diameter range H7 (mm)	$D_{1/2}$			3 - 8			4 - 12.7			4 - 16			8 - 25			12 - 32			19 - 36			20 - 45			28 - 60			35 - 80		
Inside diameter of elastomer (mm)	D_e			6.2			10.2			14.2			19.2			26.2			29.2			36.2			46.2			60.5		
Clamping screw (ISO 4762)	E			M2			M3			M4			M5			M6			M8			M10			M12			M16		
Tightening torque of the clamping screw (Nm)	E			0.6			2			4			8			15			35			70			120			290		
Distance between centers (mm)	F			5.5			8			10.5			15.5			21			24			29			38			50.5		
Distance (mm)	G			3			4			5			8.5			10			11			15			17.5			23		
Hub length (mm)	H			12			16.7			20.7			31			36			39			52			57			74		
Moment of inertia per hub (10^{-3} kgm^2) J_1/J_2	J_1/J_2			0.0003			0.002			0.003			0.01			0.04			0.08			0.3			0.66			8		
Approx. weight (kg)				0.008			0.02			0.05			0.12			0.3			0.5			0.9			1.5			8.5		
Speed standard (min^{-1})				15,000			15,000			13,000			12,500			11,000			10,000			9,000			8,000			4,000		
Speed balanced (10^3 min^{-1})	60	67	45	57	65	43	53	63	40	45	60	35	31	31	25	22	26	18	22	26	16	16	17	12	13	13	8			

For information on shaft misalignment, torsional stiffness, and other details about the elastomer inserts see pages 72 + 73.

* Maximum transmittable torque of the clamping hub depends on the bore diameter

Size	Ø 3	Ø 4	Ø 5	Ø 8	Ø 16	Ø 19	Ø 25	Ø 30	Ø 32	Ø 35	Ø 45	Ø 50	Ø 55	Ø 60	Ø 65	Ø 70	Ø 75	Ø 80
2	0.2	0.8	1.5	2.5														
5		1.5	2	8														
10			4	12	32													
20				20	35	45	60											
60					50	80	100	110	120									
150						120	160	180	200	220								
300						200	230	300	350	380	420							
450								420	480	510	600	660	750	850				
800										700	750	800	835	865	900	925	950	1,000

Higher torque possible with keyways.



WITH SPLIT CLAMPING HUB

4 - 2,150 Nm



PROPERTIES

FEATURES

- ▶ lateral mounting
- ▶ easy installation and removal
- ▶ allows for pre-alignment of shafts

DESIGN

Two concentrically machined, fully split hubs with curved jaws and clamping screws.

MATERIAL

- ▶ **Hubs:** up to size 450 high strength aluminum; size 800 steel
- ▶ **Elastomer:** wear resistant thermally stable TPU

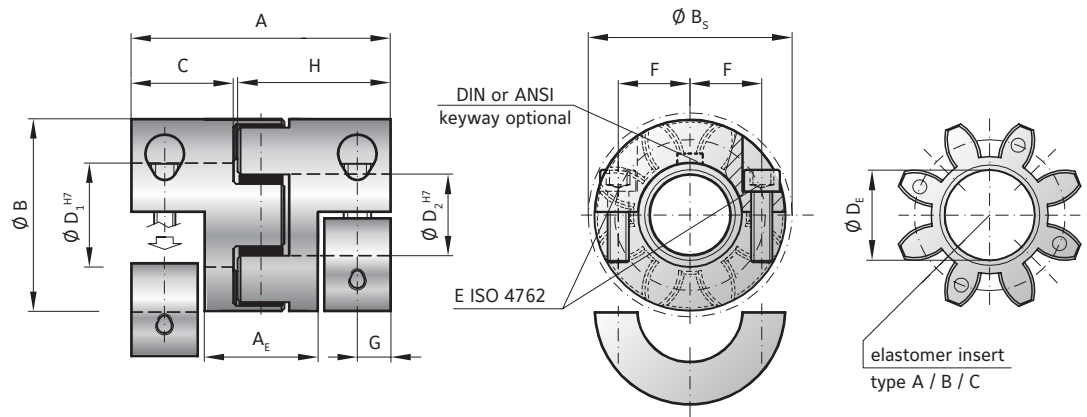

MODEL EKH

SIZE	10			20			60			150			300			450			800		
Type (Elastomer insert)	A	B	C	A	B	C	A	B	C	A	B	C	A	B	C	A	B	C	A	B	C
Rated torque (Nm) T _{KN}	12.6	16	4	17	21	6	60	75	20	160	200	42	325	405	84	530	660	95	950	1100	240
Max. torque* (Nm) T _{Kmax}	25	32	6	34	42	12	120	150	35	320	400	85	650	810	170	1060	1350	190	1900	2150	400
Overall length (mm) A	53			66			78			90			114			126			162		
Length of center section (mm) A _E	20			28.8			34			38			50			52			65		
Outside diameter (mm) B	32			42			56			66.5			82			102			136.5		
Outside diameter with screw head (mm) B _s	32			44.5			57			68			85			105			139		
Mounting length (mm) C	20			25			30			35			45			50			65		
Inside diameter range H7 (mm) D _{1/2}	6 - 16			8 - 25			12 - 32			19 - 36			20 - 45			28 - 60			35 - 80		
Inside diameter of elastomer (mm) D _E	14.2			19.2			26.2			29.2			36.2			46.2			60.5		
Clamping screw (ISO 4762) E	4 x M4			4 x M5			4 x M6			4 x M8			4 x M10			4 x M12			4 x M16		
Tightening torque of the clamping screw (Nm)	4			8			15			35			70			120			290		
Distance between centers (mm) F	10.5			15.5			21			24			29			38			50.5		
Distance (mm) G/G ₁	7.5			8.5			10			12			15			17.5			23		
Hub length (mm) H/H ₁	31			39			46			52.5			66			73			93.5		
Moment of inertia per hub (10 ⁻³ kgm ²) J _{1/2}	0.005			0.02			0.06			0.1			0.4			1			9.5		
Approx. weight (kg)	0.08			0.15			0.35			0.6			1.1			1.7			10		
Speed standard (min ⁻¹)	13,000			12,500			11,000			10,000			9,000			8,000			4,000		
Speed balanced (10 ³ min ⁻¹)	53	63	40	45	60	35	31	31	25	22	26	18	22	26	16	16	17	12	13	13	8

For information on shaft misalignment, torsional stiffness, and other details about the elastomer inserts see pages 72 + 73.

* Maximum transmittable torque of the clamping hub depends on the bore diameter

Size	Ø 6	Ø 8	Ø 16	Ø 19	Ø 25	Ø 30	Ø 32	Ø 35	Ø 45	Ø 50	Ø 55	Ø 60	Ø 65	Ø 70	Ø 75	Ø 80	Ø 90	Ø 120	Ø 140
10	6	12	32																
20		30	40	50	65														
60			65	120	150	180	200												
150				180	240	270	300	330											
300				300	340	450	520	570	630										
450						630	720	770	900	1120	1180	1350							
800								1050	1125	1200	1300	1400	1450	1500	1550	1600			
2500								1400	1800	2000	2250	2500	2700	2900	3100	3300	3700		
4500								2400	2600	2900	3100	3400	3600	3900	4100	4700	6200		
9500									5000	5500	6000	6500	7000	7500	8000	9000	12000	14000	

Higher torque possible with keyways



PROPERTIES

FEATURES

- ▶ lateral mounting
- ▶ easy installation and removal
- ▶ allows for pre-alignment of shafts

MATERIAL

- ▶ **Hubs:** GGG 40
- ▶ **Elastomer:** wear resistant thermally stable TPU

DESIGN

Two concentrically machined, fully split hubs with curved jaws and clamping screws. Elastomer insert consist of 5 segments.

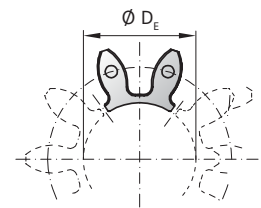
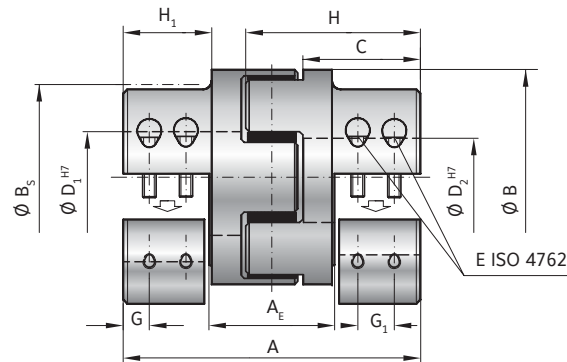

elastomer insert type A / B

MODEL EKH

SIZE		2500		4500		9500	
Type (Elastomer insert)		A	B	A	B	A	B
Rated torque (Nm)	T_{KN}	1950	2450	5000	6200	10000	12500
Max. torque* (Nm)	T_{Kmax}	3900	4900	10000	12400	20000	25000
Overall length (mm)	A	213		272		341	
Length of center section (mm)	A_e	78		104		131	
Outside diameter (mm)	B	160		225		290	
Outside diameter with screw head (mm)	B_s	156		199		243	
Mounting length (mm)	C	85		113		140	
Inside diameter range H7 (mm)	$D_{1/2}$	35 - 90		40 - 120		50 - 140	
Inside diameter of elastomer (mm)	D_e	80		111		145	
Clamping screw (ISO 4762)		8 x M16		8 x M20		8 x M24	
Tightening torque of the clamping screw (Nm)	E	300		600		1100	
Distance between centers (mm)	F	57		75		90	
Distance (mm)	G/G_1	18 / 30		24 / 41		30 / 48	
Hub length (mm)	H/H_1	120 / 69		154 / 89		193 / 110	
Moment of inertia per hub (10^{-3} kgm^2)	J_1/J_2	40		147		480	
Approx. weight (kg)		12.5		25		53	
Speed standard (min^{-1})		3,000		3,500		2,000	
Speed balanced (10^3 min^{-1})		10	10	8	8	6.5	6.5

For information on shaft misalignment, torsional stiffness, and other details about the elastomer inserts see pages 72 + 73.

* Maximum transmittable torque of the clamping hub depends on the bore diameter see page 70.

ORDERING EXAMPLE	EKL EK2 EKH	60	A	12.7	24	XX
Model	●					
Size		●				
Elastomer insert type			●			
Bore D1 H7				●		
Bore D2 H7					●	
For custom features place an XX at the end of the part number and describe the special requirements (e.g. EKH / 60 / A / 12.7 / 24 / XX; XX=anodized aluminum)						

EK6

WITH CONICAL CLAMPING RING

4 - 2,150 Nm



PROPERTIES

FEATURES

- ▶ high clamping pressure
- ▶ self centering on shaft
- ▶ very high concentricity

DESIGN

Two concentrically machined hubs with curved jaws and conical clamping rings.

MATERIAL

- ▶ **Hubs:** up to size 450 high strength aluminum; size 800 steel
- ▶ **Elastomer:** wear resistant thermally stable TPU

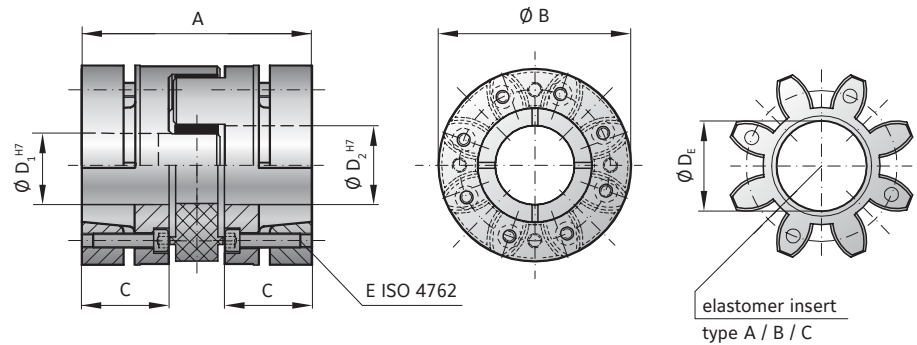

MODEL EK6

SIZE	10			20			60			150			300			450			800		
Type (Elastomer insert)	A	B	C	A	B	C	A	B	C	A	B	C	A	B	C	A	B	C	A	B	C
Rated torque (Nm) T_{KN}	12.5	16	4	17	21	6	60	75	20	160	200	42	325	405	84	530	660	95	950	1100	240
Max. torque (Nm) T_{Kmax}	25	32	6	34	42	12	120	150	35	320	400	85	650	810	170	1060	1350	190	1900	2150	400
Overall length (mm) A	42			56			64			76			96			110			138		
Outside diameter (mm) B/B ₂	32			43			56			66.5			82			102			136.5		
Mounting length (mm) C	15			20			23			28			36			42			53		
Inside diameter range H7 (mm) D _{1/2}	6 - 16			8 - 24			12 - 32			19 - 35			20 - 45			28 - 55			32 - 80		
Inside diameter of elastomer (mm) D _E	14.2			19.2			26.2			29.2			36.2			46.2			60.5		
Clamping screw (ISO 4762) E	3x M3			6x M4			4x M5			8x M5			8x M6			8x M8			8x M10		
Tightening torque of the clamping screw (Nm)	2			3			6			7			12			35			55		
Distance (mm) F																					
Moment of inertia per hub (10^{-3} kgm ²) J ₁ /J ₂	0.004			0.015			0.05			0.1			0.3			0.85			9.2		
Approx. weight (kg)	0.08			0.12			0.3			0.5			0.9			1.5			9.6		
Speed standard (min ⁻¹)	20,000			19,000			14,000			13,000			10,000			9,000			4,000		
Speed balanced (10 ³ min ⁻¹)	53	63	40	45	60	35	31	31	25	22	26	18	22	26	16	16	17	12	13	13	8

For information on shaft misalignment, torsional stiffness, and other details about the elastomer inserts see pages 72 + 73.

ORDERING EXAMPLE	EK6	60	A	19	22.23	XX
Model	●					Special designation only (e.g. special bore tolerance).
Size		●				
Elastomer insert type			●			
Bore D1 H7				●		
Bore D2 H7					●	

For custom features place an XX at the end of the part number and describe the special requirements (e.g. EK6 / 60 / A / 19 / 22.23 / XX; XX=finely balanced ISO G2.5 / 30,000 rpm)

EK6

WITH CONICAL CLAMPING RING

1,950 - 25,000 Nm



PROPERTIES

FEATURES

- ▶ high clamping pressure
- ▶ self centering on shaft
- ▶ very high concentricity

DESIGN

Two concentrically machined hubs with curved jaws and conical clamping rings. Elastomer insert consist of 5 segments.

MATERIAL

- ▶ **Hubs:** GGG40
- ▶ **Elastomer:** wear resistant thermally stable TPU

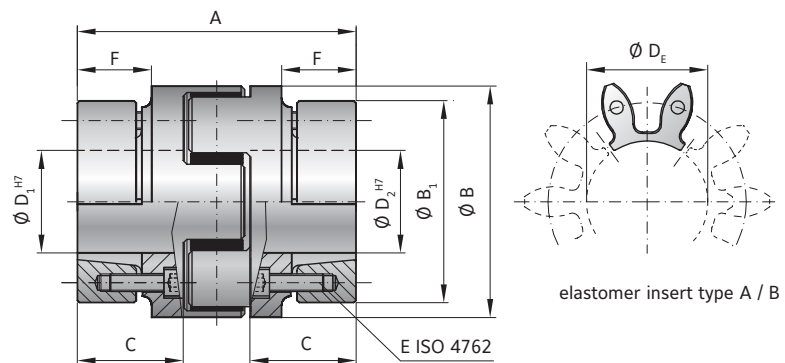

MODEL EK6

SIZE		2500		4500		9500	
Type (Elastomer insert)		A	B	A	B	A	B
Rated torque (Nm)	T_{KN}	1950	2450	5000	6200	10000	12500
Max. torque (Nm)	T_{Kmax}	3900	4900	10000	12400	20000	25000
Overall length (mm)	A	177		227		282	
Outside diameter (mm)	B/B ₁	160 / 159		225 / 208		290 / 285	
Mounting length (mm)	C	70		90		112	
Inside diameter range H7 (mm)	D _{1/2}	40 - 95		50 - 130		60 - 170	
Inside diameter of elastomer (mm)	D _E	80		111		145	
Clamping screw (ISO 4762)		10x M10		10x M12		10x M16	
Tightening torque of the clamping screw (Nm)	E	60		100		160	
Distance (mm)	F	51		66		80	
Moment of inertia per hub (10 ⁻³ kgm ²)	J ₁ /J ₂	31.7		135.7		469.2	
Approx. weight (kg)		15		35		73	
Speed standard (min ⁻¹)		3,500		3,000		2,000	
Speed balanced (10 ³ min ⁻¹)		10	10	8	8	6.5	6.5

For information on shaft misalignment, torsional stiffness, and other details about the elastomer inserts see pages 72 + 73.

ORDERING EXAMPLE	EK6	2500	A	50.8	80	XX
Model	●					Special designation only (e.g. special bore tolerance).
Size		●				
Elastomer insert type			●			
Bore D1 H7				●		
Bore D2 H7					●	
For custom features place an XX at the end of the part number and describe the special requirements (e.g. EK6 / 2500 / A / 50.8 / 80 / XX; XX=stainless steel)						

SP6

HIGH SPEED WITH CONICAL CLAMPING RING

60 - 1,350 Nm

NEW



High speed

PROPERTIES

FEATURES

- ▶ very high precision
- ▶ very high concentricity
- ▶ high clamping force
- ▶ symmetrically machined hubs

▶ **Elastomer: wear resistant thermally stable TPU**

DESIGN

Two precision machined hubs with curved jaws and conical clamping rings.

MATERIAL

- ▶ **Hubs: high strength aluminium; optional steel**
- ▶ **Clamping ring: high strength aluminium; optional steel**

FIT CLEARANCE

Overall shaft / hub tolerance
0.01 - 0.025 mm

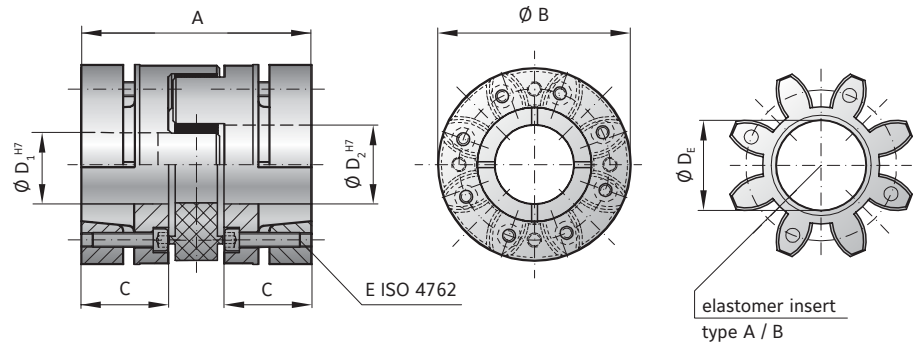

MODEL SP6

SIZE		60		150			300		450		
Type (Elastomer insert)		A	B	A	B	A	B	A	B		
Rated torque (Nm)	T_{KN}	60	75	160	200	325	405	530	660		
Max. torque (Nm)	T_{Kmax}	120	150	320	400	650	810	1060	1350		
Overall length (mm)	A	64	78	80	90	100	114	110	126	140	
Outside diameter (mm)	B	55		65			80		102		
Mounting length (mm)	C	23	30	30	35	40	45	42	50	57	
Inside diameter range H7 (mm)	$D_{1/2}^*$	14 - 32		19 - 38			20 - 48**		28 - 55		
Inside diameter of elastomer (mm)	D_e	26.2		29.2			36.2		46.2		
Hub material		AL / optional steel		AL / optional steel			AL / optional steel		AL / optional steel		
Clamping screw (ISO 4762)		4x M5		8x M5			8x M6		8x M8		
Tightening torque of the clamping screw - AL / steel (Nm)	E	6 / 6	7 / 7	7 / 8.5	7.5 / 8.5	8.5 / 8.5	14 / 14	25 / 30			
Moment of inertia per hub AL / steel (10^{-3} kgm^2)	J_1/J_2	0.06 / 0.15	0.08 / 0.20	0.16 / 0.38	0.18 / 0.44	0.20 / 0.50	0.52 / 1.29	1.33 / 3.31	1.55 / 3.88	1.74 / 4.38	
Approx. weight total - AL / steel (kg)		0.25 / 0.62	0.32 / 0.78	0.46 / 1.10	0.53 / 1.30	0.60 / 1.43	1.00 / 2.41	1.70 / 4.00	1.90 / 4.70	2.20 / 5.20	
Speed standard (min-1)		28,000		26,000			26,000		18,000		

For information on shaft misalignment, torsional stiffness, and other details about the elastomer inserts see pages 72 + 73.

* Recommended fit pairing H7/k6; H6/j5 (short spindle); starting at Ø55 G7/m6

** from Ø46 to 48 with custom hub

ORDERING EXAMPLE	SP6	150	90	A	32	25.4	XX
Model	●						Special designation only (e.g. hub material steel).
Size		●					
Overall length			●				
Elastomer insert type				●			
Bore D1 H7					●		
Bore D2 H7						●	
For custom features place an XX at the end of the part number and describe the special requirements (e.g. SP6 / 150 / 90 / A / 32 / 25.4 / XX; XX=hub material steel)							

EK7

WITH EXPANDING SHAFT

2 - 2,150 Nm



PROPERTIES

FEATURES

- ▶ for hollow shaft mounting
- ▶ short overall length
- ▶ solution for mismatched bore / shaft diameters

MATERIAL

- ▶ **Hubs:** up to size 450 high strength aluminum; size 800 steel
- ▶ **Expanding shaft hub:** steel

- ▶ **Elastomer:** wear resistant thermally stable TPU

DESIGN

One concentrically machined hub with clamping screw and curved jaws. One concentrically machined hub with expanding shaft system and curved jaws.

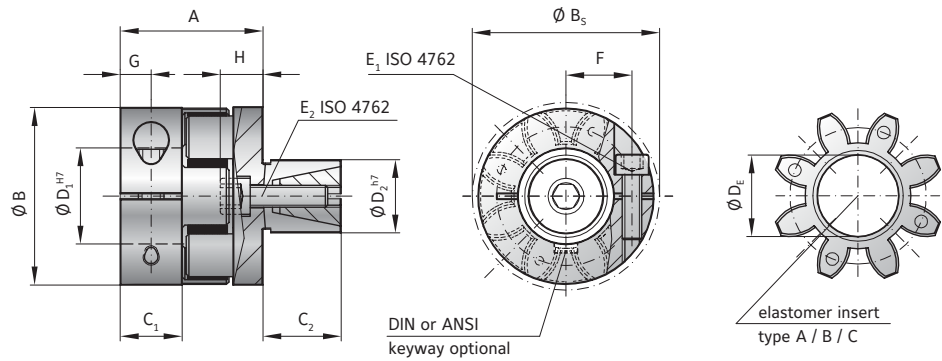

MODEL EK7

SIZE	5			10			20			60			150			300			450			800			
	A	B	C	A	B	C	A	B	C	A	B	C	A	B	C	A	B	C	A	B	C	A	B	C	
Type (Elastomer insert)																									
Rated torque (Nm)	T_{KN}	9	12	2	12.5	16	4	17	21	6	60	75	20	160	200	42	325	405	84	530	660	95	950	1100	240
Max. torque* (Nm)	T_{Kmax}	18	24	4	25	32	6	34	42	12	120	150	35	320	400	85	650	810	170	1060	1350	190	1900	2150	400
Overall length (mm)	A	22			28			40			46			51			68			76			94		
Outside diameter (mm)	B	25			32			42			56			66.5			82			102			136.5		
Outside diameter with screw head (mm)	B_s	25			32			44.5			57			68			85			105			139		
Mounting length (mm)	C_1	8			10.3			17			20			21			31			34			46		
Mounting length (mm)	C_2	12			20			25			27			32			45			55			60		
Inside diameter range H7 (mm)	D_1	4 - 12.7			5 - 16			8 - 25			12 - 32			19 - 36			20 - 45			28 - 60			35 - 80		
Outside diameter range h7 (mm)	D_2	10 - 16			13 - 25			14 - 30			23 - 38			26 - 42			38 - 60			42 - 70			42 - 80		
Inside diameter of elastomer (mm)	D_e	10.2			14.2			19.2			26.2			29.2			36.2			46.2			60.5		
Clamping screw (ISO 4762)	E_1	M3			M4			M5			M6			M8			M10			M12			M16		
Tightening torque (Nm)	E_1	2			4			8			15			35			70			120			290		
Clamping screw (ISO 4762)	E_2	M4			M5			M6			M8			M10			M12			M16			M16		
Tightening torque (Nm)	E_2	4			9			12			32			60			110			240			300		
Distance between centers (mm)	F	8			10.5			15.5			21			24			29			38			50.5		
Distance (mm)	G	4			5			8.5			10			11			15			17.5			23		
Length (mm)	H	7			7			10			11			16			20			27			27		
Moment of inertia D_1 (10^{-3} kgm^2)	J_1	0.002			0.003			0.01			0.04			0.08			0.3			0.66			8		
Moment of inertia D_2 (10^{-3} kgm^2)	J_2	0.002			0.01			0.04			0.1			0.2			1			2.6			9		
Approx. weight (kg)		0.04			0.05			0.12			0.3			0.5			0.9			1.5			7.6		
Speed standard (min^{-1})		15,000			13,000			12,500			11,000			10,000			9,000			8,000			4,000		
Speed balanced (10^3 min^{-1})		57	65	43	53	63	40	45	60	35	31	31	25	22	26	18	22	26	16	16	17	12	13	13	8

For information on shaft misalignment, torsional stiffness, and other details about the elastomer inserts see pages 72 + 73.

* Maximum transmittable torque of the clamping hub depends on the bore diameter (see EKL on page 68).

ORDERING EXAMPLE	EK7	20	A	24	19.05	XX
Model	●					
Size		●				
Elastomer insert type			●			
Bore D1 H7				●		
Expanding shaft D2 h7					●	
For custom features place an XX at the end of the part number and describe the special requirements (e.g. EK7 / 20 / A / 24 / 19.05 / XX; XX=stainless steel)						

Special designation only (e.g. special bore tolerance).

ELASTOMER COUPLINGS EK | TX



INTERMEDIATE SPACER

0.5 - 2,150 Nm

PROPERTIES



FEATURES

- ▶ high lateral misalignment
- ▶ easy to mount
- ▶ combine with any two hub designs

MATERIAL

- ▶ **Hubs:** high strength aluminum
- ▶ **Elastomer:** wear resistant thermally stable TPU

DESIGN

A concentrically machined spacer with curved jaws. 2x elastomer segment press fit for zero backlash; standard versions are electrically isolating.

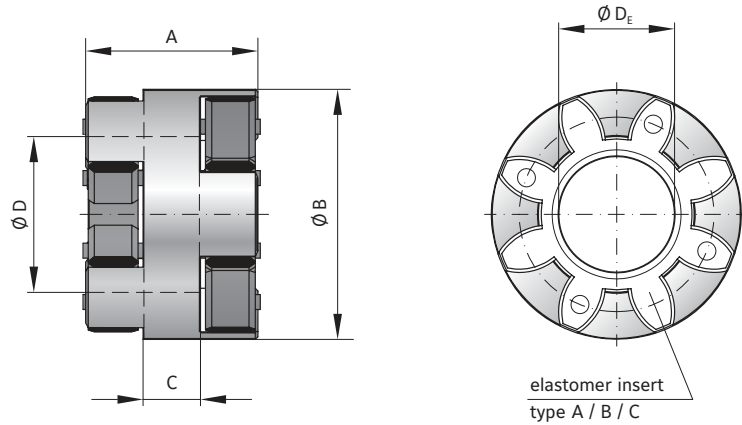

MODEL EKZ

SIZE	2			5			10			20			60			150			300			450			800					
Type (Elastomer insert)	A	B	C	A	B	C	A	B	C	A	B	C	A	B	C	A	B	C	A	B	C	A	B	C	A	B	C	A	B	C
Rated torque (Nm) T_{KN}	2	2.4	0.5	9	12	2	12.5	16	4	17	21	6	60	75	20	160	200	42	325	405	84	530	660	95	950	1100	240			
Max. torque (Nm) T_{Kmax}	4	4.8	1	18	24	4	25	32	6	34	42	12	120	150	35	320	400	85	650	810	170	1060	1350	190	1900	2150	400			
Overall length (mm) A	20			26			30			39			48			53			62			86			81					
Outside diameter (mm) B	16			25			32			42			56			66.5			82			102			136.5					
Hub length (mm) C	9			9			9			10			16			18			20			40			25					
Inside diameter (mm) D	9			15			18			25			32			38			45			60			80					
Inside diameter of elastomer (mm) D_E	6.2			10.2			14.2			19.2			26.2			29.2			36.2			46.2			60.5					
Moment of inertia (10^{-3} kgm^2) J_1/J_2	0.0001			0.0005			0.002			0.008			0.03			0.05			0.1			0.6			1.1					
Approx. weight (kg)	0.007			0.02			0.04			0.09			0.21			0.33			0.58			1.38			2.09					
Speed standard (min^{-1})	15,000			15,000			13,000			12,500			11,000			10,000			9,000			8,000			4,000					

For information on shaft misalignment, torsional stiffness, and other details about the elastomer inserts see pages 72 + 73.

ORDERING EXAMPLE	EKZ	60	A	XX
Model	●			
Size		●		
Elastomer insert type			●	
Special designation only (e.g. non-standard length).				
For custom features place an XX at the end of the part number and describe the special requirements (e.g. EKZ / 60 / A / XX; XX=anodized aluminum)				

WORKS WITH FULL PRODUCT RANGE



EK1



EK2



EK6

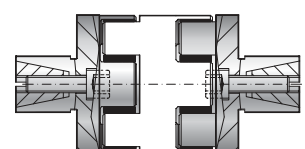

EK7

EK4

FOR CONICAL SHAFT ENDS

20 - 150 Nm



PROPERTIES

FEATURES

- ▶ for tapered shafts
- ▶ short compact design
- ▶ easy assembly
- ▶ concentrically machined hubs
- ▶ backlash free
- ▶ electrically isolating

MATERIAL

- ▶ **Clamping hub D₁**: high strength aluminum

- ▶ **Conical hub D₂**: steel
- ▶ **Elastomer**: wear resistant thermally stable TPU

DESIGN

Two coupling hubs are concentrically machined with curved jaws. One side with clamping hub and screw per ISO 4762. One side with tapered bore and keyway per customer specifications.

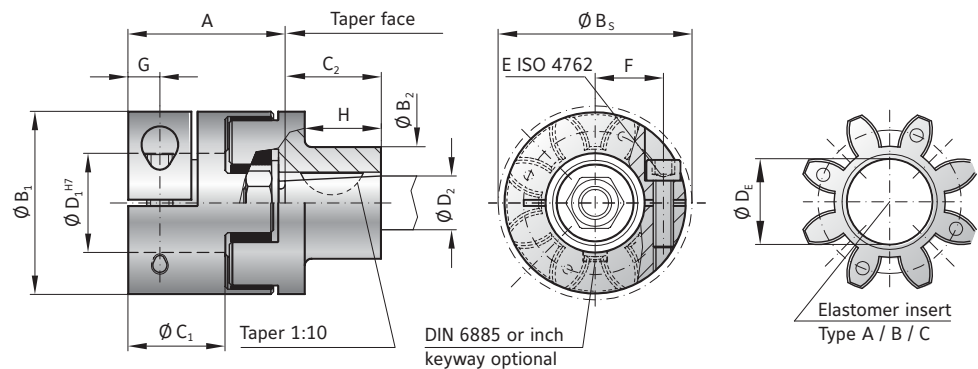

MODEL EK4

SIZE		20			60			150		
Type (Elastomer insert)		A	B	C	A	B	C	A	B	C
Rated torque	(Nm) T _{KN}	17	21	6	60	75	20	160	200	42
Max. torque*	(Nm) T _{Kmax}	34	42	12	120	150	35	320	400	85
Overall length	(mm) A	42			50			57		
Outside diameter of clamping hub	(mm) B ₁	42			56			66.5		
Outside diameter of tapered bore hub	(mm) B ₂	20			28			30		
Outside diameter with screw head	(mm) B ₅	44.5			57			68		
Mounting length	(mm) C ₁	25			30			35		
Mounting length	(mm) C ₂	15			27			28		
Inside diameter range H7	(mm) D ₁	8-25			12-32			19-36		
Possible tapered bore diameter	(mm) D ₂	11			16			16		
Inside diameter of elastomer	(mm) D _E	19.2			26.2			29.2		
Clamping screw (ISO 4762)	(Nm) E	M5			M6			M8		
Tightening torque of the clamping screw		8			15			35		
Distance between centers	(mm) F	15.5			21			24		
Distance	(mm) G	8.5			10			12		
Length	(mm) H	9.5			21			19		
Speed standard	(min ⁻¹)	12500			11000			10000		
Speed balanced	(10 ³ min ⁻¹)	45	60	35	31	31	25	22	26	18

* in Maximum transmittable torque depends on the bore diameter (overall clearance between shaft and hub 0.01 to 0.05 mm; shaft oiled) Higher torques upon request.

For information on shaft misalignment, torsional stiffness, and other details about the elastomer inserts see pages 72 + 73.

ORDERING EXAMPLE	EK4	20	A	24	XX
Model	●				Non standard e.g. finely balanced
Size		●			
Type Elastomer insert			●		
Bore Ø D1 H7				●	
For custom features place an XX at the end of the part number and describe the special requirements (e.g. EK4 / 20 / A / 24 / XX)					