

rev.4

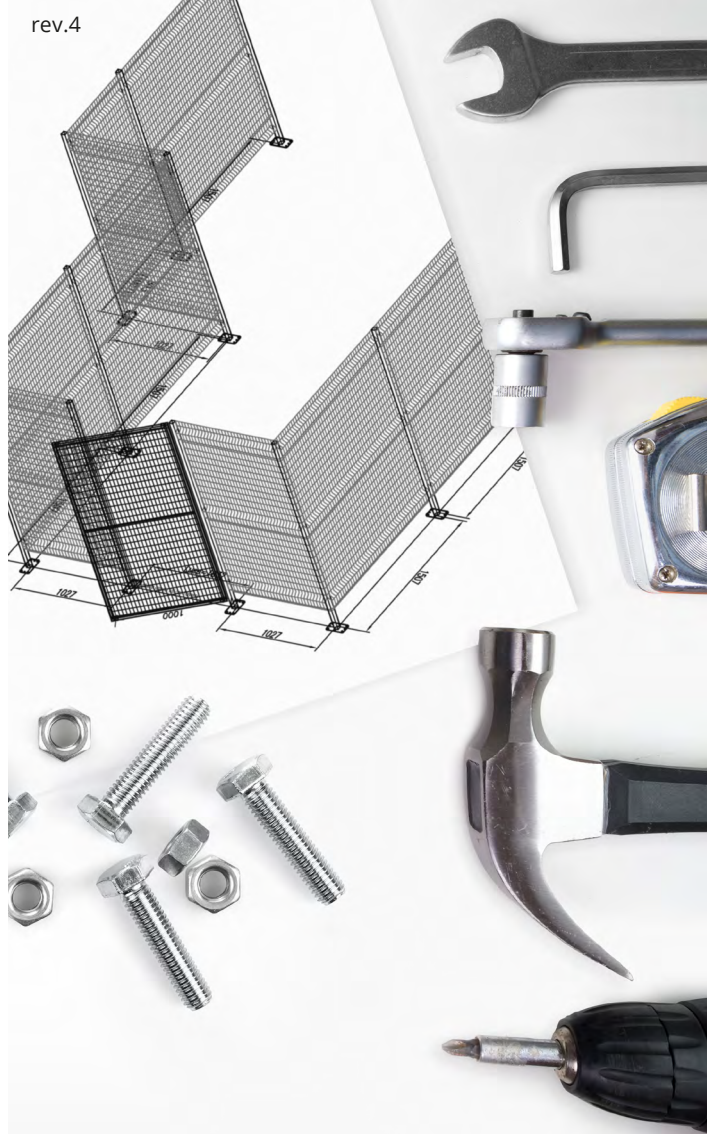

 **PROTEC**

Manuale di istruzioni

Instruction manual  
Manuel d'instruction  
Bedienungsanleitung  
Manual de instrucciones



Description	Page
<b>7040001043 + 101010108</b>	<b>26</b>
<ul style="list-style-type: none"> <li>□ Piedino intermedio di appoggio ECOTEK</li> <li>Intermediate support foot ECOETK</li> <li>Zwischenstützfuß ECOTEK</li> <li>Pied de support intermédiaire ECOTEK</li> <li>Pie de apoyo intermedio ECOTEK</li> </ul>	
<b>101010014 (KFN004)</b>	<b>27</b>
<ul style="list-style-type: none"> <li>□ Montaggio pannello al montante tratti inclinati NOVATEK - ECOTEK</li> <li>Panel assembly on posts in leaning sections NOVATEK - ECOTEK</li> <li>Paneeleinbau mit Schrägprofilen NOVATEK - ECOTEK</li> <li>Montage des panneaux sur les montants avec sections inclinées NOV - ECO</li> <li>Ensamblaje de los paneles a los postes en las secciones inclinadas NOV - ECO</li> </ul>	
<b>101010037 (KFN010)</b>	<b>28</b>
<ul style="list-style-type: none"> <li>□ Montaggio pannelli speciali al montante NOVATEK - ECOTEK</li> <li>Assembly of special panels to post NOVATEK - ECOTEK</li> <li>Einbau spezieller Paneele an den Pfosten NOVATEK - ECOTEK</li> <li>Assemblage de panneaux spéciaux au montant NOVATEK - ECOTEK</li> <li>Ensamblaje de paneles especiales a los postes NOVATEK - ECOTEK</li> </ul>	
<b>101010062</b>	<b>29</b>
<ul style="list-style-type: none"> <li>□ Montaggio tratti rettilinei con viti imperdibili NOVATEK</li> <li>Assembly to intermediate posts with captive fasteners NOVATEK</li> <li>Einbau an den Zwischenpfosten mit unverlierbaren Schrauben NOVATEK</li> <li>Montage sur le montant intermédiaire avec des vis imperdables NOVATEK</li> <li>Ensamblaje al poste intermedio con tornillos imperdibles NOVATEK</li> </ul>	
<b>101010063</b>	<b>30</b>
<ul style="list-style-type: none"> <li>□ Montaggio tratti terminali con viti imperdibili NOVATEK</li> <li>Assembly of end sections with captive fasteners NOVATEK</li> <li>Befestigung der Anschlussabschnitten mit unverlierbaren Schrauben NOVATEK</li> <li>Assemblage de sections terminales avec des vis imperdables NOVATEK</li> <li>Montaje de secciones terminales con tornillos cautivos NOVATEK</li> </ul>	
<b>101010104C (H=2000) - 101010107C (H=2520)</b>	<b>31</b>
<ul style="list-style-type: none"> <li>☞ Montaggio terminale con viti imperdibili TECHNO</li> <li>Assembly to posts with captive fasteners TECHNO</li> <li>Einbau mit unverlierbaren Schrauben TECHNO</li> <li>Assemblage à la verticale du terminal avec des vis imperdables TECHNO</li> <li>Ensamblaje de los paneles con tornillos imperdibles TECHNO</li> </ul>	
<b>101010103C (H=2000) - 101010106C (H=2520)</b>	<b>32</b>
<ul style="list-style-type: none"> <li>☞ Montaggio angolare con viti imperdibili TECHNO</li> <li>Angle panels assembly with captive fasteners TECHNO</li> <li>Eckpaneele Einbau mit unverlierbaren Schrauben TECHNO</li> <li>Montage des panneaux au montant terminal avec des vis imperdables TECHNO</li> <li>Ensamblaje de los paneles angulares con tornillos imperdibles TECHNO</li> </ul>	
<b>101010102C (H=2000) - 101010105C (H=2520)</b>	<b>33</b>
<ul style="list-style-type: none"> <li>☞ Montaggio intermedio con viti imperdibili TECHNO</li> <li>Assembly to intermediate posts with captive fasteners TECHNO</li> <li>Einbau an den Zwischenpfosten mit unverlierbaren Schrauben TECHNO</li> <li>Montage sur le montant intermédiaire avec des vis imperdables TECHNO</li> <li>Ensamblaje al poste intermedio con tornillos imperdibles TECHNO</li> </ul>	
<b>101010042C (H=2000) - 101010079C (H=2520)</b>	<b>34</b>
<ul style="list-style-type: none"> <li>☞ Montaggio pannelli al montante a 90° convessi TECHNO</li> <li>Mounting panels to the post at 90° convex sections TECHNO</li> <li>Montage der Paneele an dem Pfosten - konvex 90° TECHNO</li> <li>Assemblage des panneaux au montant pour les sections convexes à 90° TECHNO</li> <li>Montaje de paneles en el montante para secciones convexas de 90° TECHNO</li> </ul>	
<b>101010043C (H=2000) - 101010061C (H=2520)</b>	<b>35</b>
<ul style="list-style-type: none"> <li>☞ Montaggio pannelli al montante angoli diversi 90° TECHNO</li> <li>Assembly of panels to the post with different 90° angles TECHNO</li> <li>Montage der Paneele an den Pfosten mit verschiedenen 90° Winkeln TECHNO</li> <li>Assemblage des panneaux au montant pour différents angles de 90° TECHNO</li> <li>Montaje de paneles a los postes con distintos ángulos de 90° TECHNO</li> </ul>	



□ NOVATEK-ECOTEK

☞ TECHNO

☞ HINGED DOOR

☞ SLIDING DOOR

Description	Page
<b>101020110 (KFTECO20)</b>	<b>36</b>
<ul style="list-style-type: none"> <li>☞ Montaggio pannelli con una piega TECHNO</li> <li>Fold panels assembly TECHNO</li> <li>Einfaltig Paneele Einbau TECHNO</li> <li>Montage des panneaux avec un pli TECHNO</li> <li>Montaje de paneles con un pliegue TECHNO</li> </ul>	
<b>101050036</b>	<b>37-39</b>
<ul style="list-style-type: none"> <li>□ Kit taglio pannelli NOVATEK</li> <li>Panels cutting kit NOVATEK</li> <li>Panel-Schneidsatz NOVATEK</li> <li>Kit de coupe de panneau NOVATEK</li> <li>Kit de corte de panel NOVATEK</li> </ul>	
<b>7030003146</b>	<b>40</b>
<ul style="list-style-type: none"> <li>□ Kit prolunga NOVATEK - ECOTEK</li> <li>Extension kit NOVATEK - ECOTEK</li> <li>Erweiterungssatz NOVATEK - ECOTEK</li> <li>Kit d'extension NOVATEK - ECOTEK</li> <li>Kit de extension NOVATEK - ECOTEK</li> </ul>	
<b>101010101</b>	<b>41</b>
<ul style="list-style-type: none"> <li>□ Kit unione NOVATEK</li> <li>Union kit NOVATEK</li> <li>Verbandskasten NOVATEK</li> <li>Kit d'union NOVATEK</li> <li>Kit de union NOVATEK</li> </ul>	
<b>1010201#00010000 (KPNV001)</b>	<b>42-43</b>
<ul style="list-style-type: none"> <li>☞ Complessivo montaggio porta ad anta singola</li> <li>Single hinged door assembly</li> <li>Einzelflügeltür</li> <li>Assemblage de porte à battant simple</li> <li>Montaje de la puerta de hoja singola</li> </ul>	
<b>1010203#00010000 (KPNV011)</b>	<b>44-46</b>
<ul style="list-style-type: none"> <li>☞ Complessivo montaggio porta ad anta doppia</li> <li>Double Hinged door assembly</li> <li>Doppelflügeltür</li> <li>Assemblage de porte à battant double</li> <li>Montaje de la puerta de doble hoja</li> </ul>	
<b>1010200024 (KPNV047)</b>	<b>47</b>
<ul style="list-style-type: none"> <li>☞ Montaggio cerniere per porte ad anta in angolo</li> <li>Hinges assembly for corner doors</li> <li>Einbau von Scharnieren für Ecktüren</li> <li>Montage de charnières pour portes d'angle</li> <li>Montaje de bisagras en puertas con hoja en ángulo</li> </ul>	
<b>101030101</b>	<b>48-49</b>
<ul style="list-style-type: none"> <li>☞ ANTA Microinterruttore a cerniera con traverso superiore</li> <li>DOOR Hinged microswitch with upper crosspiece</li> <li>TÜR Schwenkbarer Mikroschalter mit oberem Querbalken</li> <li>PORTE Micro-interrupteur à charnière avec traverse supérieure</li> <li>PUERTA Microinterruptor con bisagras con con guía superior</li> </ul>	
<b>101030100</b>	<b>50-51</b>
<ul style="list-style-type: none"> <li>☞ ANTA Microinterruttore a cerniera senza traverso superiore</li> <li>DOOR Hinged microswitch without upper crosspiece</li> <li>TÜR Schwenkbarer Mikroschalter ohne oberes Querstück</li> <li>PORTE Micro-interrupteur articulé sans traverse supérieure</li> <li>PUERTA Microinterruptor con bisagra sin travesaño superior</li> </ul>	
<b>101030149</b>	<b>52</b>
<ul style="list-style-type: none"> <li>☞ ANTA Microinterruttore a chiave</li> <li>DOOR Key-operated microswitch</li> <li>TÜR Schlüssel-Mikroschalter</li> <li>PORTE Micro-interrupteur à clé</li> <li>PUERTA Microinterruptor accionado por llave</li> </ul>	









Description	Page
<b>101030149 + 7030002872</b>	<b>53</b>
 ANTA Microinterruttore a chiave + Carter di schermatura DOOR Key-operated microswitch + Shielding casing TÜR Schlüssel-Mikroschalter + Schieldgehäuse PORTE Micro-interrupteur à clé + Boîtier blindé PUERTA Microinterruptor con llave + Carter de protección	
<b>101030096</b>	<b>54-55</b>
 ANTA Elettroserratura DOOR Electro lock TÜR Elektroschloss PORTE Serrure électrique PUERTA Electrobloqueo	Elettroserratura + Carter per schermatura Electro lock + Shield casing Elektroschloss + Schildgehäuse Serrure électrique + Boîtier de blindage Electrobloqueo + Carter de protección
<b>101020021 (Right) - 10120022 (Left)</b>	<b>56</b>
 Serratura a chiave per porta ad anta singola (destra o sinistra) Key lock assembly for single hinged door (right or left) Schlüsselschloss für einflügelige Tür (rechts oder links) Serrure à clé pour porte à un vantail (droite ou gauche) Cerradura con llave para puerta de hoja individual (derecha o izquierda)	
<b>101020021</b>	<b>57</b>
 Serratura a chiave per porta ad anta doppia Key lock assembly for double hinged door Schlüsselschloss für zweiflügelige Tür Serrure à clé pour porte simple ou double battant Conjunto de cerradura con llave para puerta de doble hoja	
<b>101020032 (KP050) + 101020275</b>	<b>58</b>
 Sistema antipánico per porta ad anta singola (Destra o Sinistra) o doppia Anti-panic system for single hinge (Right or Left) or double door Anti-Panik-System für einflügelige Tür (rechts oder links) oder doppelt Système anti-panique pour porte à une vantail (droite ou gauche) ou double Sistema antipánico para puerta de una sola hoja (derecha o izquierda) o doble	
<b>7030401068</b>	<b>59</b>
 Staffa per kit porte scorrevoli su montante 50x50 Bracket for sliding door kit on 50x50 upright Halterung für Schiebetür-Bausatz am Pfosten 50x50 Crochet pour kit de porte coulissante sur poteau 50x50 Soporte para kit de puerta corredera con poste de 50x50	
<b>101020235 (KPNV031)</b>	<b>60-63</b>
 Complessivo montaggio porta scorrevole a terra singola Single sliding door to the ground assembly Einzel-Schiebetür-Baugruppe Assemblage d'une seule porte coulissante Conjunto de montaje de puerta deslizante simple	
<b>101020238 (KPNV032)</b>	<b>64-68</b>
 Complessivo montaggio porta scorrevole a terra doppia Double sliding door to the ground assembly Doppel-Schiebetür-Baugruppe Ensemble d'assemblage de porte coulissante double Conjunto de montaje de puerta deslizante doble	
<b>101020168</b>	<b>69-72</b>
 Montaggio porta scorrevole a terra singola con piastra da 300 mm Single sliding door to the ground assembly with 300 mm plate Einzel-Schiebetür-Baugruppe mit 300 mm Platte Ensemble de porte coulissante simple avec plaque de 300 mm Conjunto de ensamblaje de puerta deslizante con placa de 300 mm	
<b>101020171</b>	<b>73-76</b>
 Montaggio porta scorrevole a terra doppia con piastra da 300 mm Double sliding door assembly with ground guide and 300 mm plate Doppel Schiebetür mit Bodenführung und 300 mm Platte FR - Double porte coulissante avec guidage au sol et plaque de 300 mm Montaje de puerta corredera doble con guía de suelo y plac de 300 mm	

 NOVATEK-ECOTEK

 TECHNO

 HINGED DOOR

 SLINDING DOOR

Description	Page
<b>101020081</b>	<b>77-81</b>
 Montaggio porta scorrevole a terra singola o doppia con ruota in gomma Single or double sliding door assembly with rubber wheel Einbau einzel oder doppel Schiebetür mit Gummirad Assemblage d'une simple ou double porte coulissante avec roue en caoutchouc ES - Montaje de puerta corredera doble o sencilla con rueda de goma	
<b>101020214</b>	<b>82-87</b>
 Kit porta autoportante Self-supporting door kit Selbsttragende Tür Kit Kit porte autoportante Kit puerta autoportante	
<b>101020234 (KPNV050)</b>	<b>88-91</b>
 Complessivo montaggio porta scorrevole sospesa singola Suspended single sliding door assembly Schwebende Einzel-Schiebetür-Baugruppe Ensemble d'assemblage de porte coulissante simple suspendu Conjunto de ensamblaje de puerta deslizante individual suspendido	
<b>101020237 (KPNV030)</b>	<b>92-95</b>
 Complessivo montaggio porta scorrevole sospesa doppia Suspended double sliding door assembly Doppelt hängende Schiebetürmontage Ensemble d'assemblage de porte coulissante à double suspension Conjunto de montaje de puerta deslizante con suspensión doble	
<b>101030102</b>	<b>96-97</b>
 Microinterruttore Microswitch Mikro Microrupteur Microinterruptor	<b>101030102 + 7030002867</b> Microinterruttore + Carter per schermatura Microswitch + Shield casing Mikro + Schildgehäuse Microrupteur + Boîtier de blindage Microinterruptor + Carter de protección
<b>101030097</b>	<b>98-99</b>
 Elettroserratura Electric lock Elektroschloss Serrure électrique Electrobloqueo	<b>101030097 + 7030002868</b> Elettroserratura + Carter per schermatura Electric lock + Shield casing Elektroschloss + Schildgehäuse Serrure électrique + Boîtier de blindage Electrobloqueo + Carter de protección
<b>101020150 (Right) - 101020151 (Left)</b>	<b>100</b>
 Serratura chiusura a chiave PORTA SINGOLA Destra-Sinistra Lock with key lock SINGLE DOOR Left-Right Schloss mit Schlüsselschloss EINZELTÜR Rechts - Links Serrure avec serrure à clé PORTE SIMPLE Droite - Gauche Cerradura con cierre de llave PUERTA INDIVIDUAL Derecha - Izquierda	
<b>101020152</b>	<b>101</b>
 Serratura chiusura a chiave PORTA DOPPIA Lock with key lock DOUBLE DOOR Schloss mit Schlüsselschloss DOUBLE DOOR Serrure avec serrure à clé DOUBLE PORTE Cerradura con cierre de llave DOUBLE DOOR	
<b>7030001105</b>	<b>102</b>
 Montaggio staffa per pannello fisso ad angolo NOVATEK Bracket assembly for angle fixed panel NOVATEK Befestigungswinkel für feste Platte in einem Winkel NOVATEK Support de montage pour panneau fixe à un angle NOVATEK Soporte de montaje para panel fijo en ángulo NOVATEK	
Dichiarazioni di conformità CE	104
Declarations of conformity CE	107
Erklärungen zur EG-Konformität	111
Déclarations de conformité CE	113
Declaraciones de conformidad CE	116

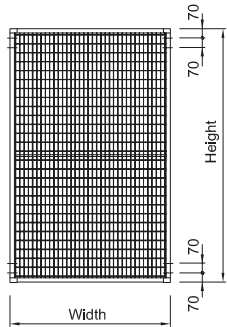
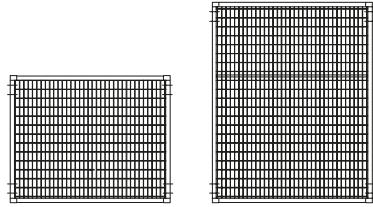

COMMERCIAL CODE	TECHNICAL CODE	Width	Height	Weight (kg)
PNNA001	0021701#0250095011020000	250	950	2,50
PNNA002	0021701#0400095011020000	400		3,00
PNNA003	0021701#0700095011020000	700		4,50
PNNA004	0021701#1000095011020000	1000		5,50
PNNA005	0021701#1200095011020000	1200		6,50
PNNA006	0021701#1500095011020000	1500		9,50
PNNA030	0021701#0250130011020000	250	1300	3,50
PNNA031	0021701#0400130011020000	400		4,50
PNNA032	0021701#0700130011020000	700		6,50
PNNA033	0021701#1000130011020000	1000		8,50
PNNA034	0021701#1200130011020000	1200		10,50
PNNA035	0021701#1500130011020000	1500		12,50
PNNA007	0021701#0250150011020000	250	1500	4,00
PNNA008	0021701#0400150011020000	400		5,00
PNNA009	0021701#0700150011020000	700		7,00
PNNA010	0021701#1000150011020000	1000		9,00
PNNA011	0021701#1200150011020000	1200		11,00
PNNA012	0021701#1500150011020000	1500		13,00
PNNA013	0021701#0250190011020000	250	1900	5,00
PNNA014	0021701#0400190011020000	400		6,00
PNNA015	0021701#0700190011020000	700		8,50
PNNA016	0021701#1000190011020000	1000		11,50
PNNA017	0021701#1200190011020000	1200		12,50
PNNA018	0021701#1500190011020000	1500		15,00

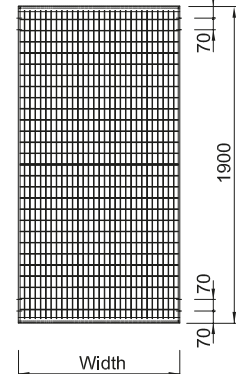
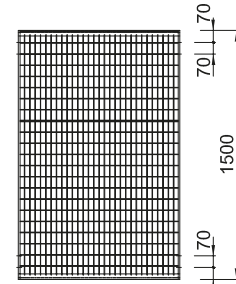

COMMERCIAL CODE	TECHNICAL CODE	Width	Height	Weight (kg)
PNNE010	0021801#0250150011020000	250	1500	3,50
PNNE011	0021801#0410150011020000	410		4,50
PNNE012	0021801#0700150011020000	700		6,00
PNNE013	0021801#1020150011020000	1020		8,00
PNNE014	0021801#1210150011020000	1210		9,00
PNNE015	0021801#1500150011020000	1500		10,50
PNNE020	0021801#0250190011020000	250	1900	4,80
PNNE021	0021801#0410190011020000	410		5,80
PNNE022	0021801#0700190011020000	700		7,20
PNNE023	0021801#1020190011020000	1020		9,20
PNNE024	0021801#1210190011020000	1210		10,00
PNNE025	0021801#1500190011020000	1500		12,00

COMMERCIAL CODE	TECHNICAL CODE	Height	Section	Plate	Weight (kg)
MT111	0020024#00000001	1050	40x40	100x180	2,50
MT114	0020024#02000001	1400	40x40	100x180	3,50
MT112	0020024#03000001	1600	40x40	100x180	4,00
MT113	0020024#05000001	2000	40x40	100x180	5,00
MT115	7020002074	2560	40x40	100x180	6,50
MT500	0020024#00000001	1050	40x80	100x180	4,30
MT503	0020024#02010001	1400	40x80	100x180	5,40
MT501	0020024#03010001	1600	40x80	100x180	6,70
MT502	0020024#05010001	2000	40x80	100x180	7,70
MT504	7020002549	2560	40x80	100x180	9,00
MT505	7020001682	2960	40x80	100x180	11,20
MT506	7020001952	3110	40x80	100x180	11,70
MT211	0020024#00020001	1050	80x80	150x150	6,00
MT214	0020024#02020001	1400	80x80	150x150	8,00
MT212	0020024#03020001	1600	80x80	150x150	8,90
MT213	0020024#05020001	2000	80x80	150x150	10,70
MT215	7020001782	2560	80x80	150x150	13,70
MT216	7020002071	2960	80x80	150x150	15,60
MT217	6020001953	3110	80x80	150x150	16,30
MT704	7020004993	2000	50x50	100x180	6,5
MT705	7020004994	2560	50x50	100x180	8,14
MT706	7020004995	2960	50x50	100x180	8,31
MT707	7020004996	3110	50x50	100x180	9,75
MT708	7020004997	3510	50x50	100x180	10,9

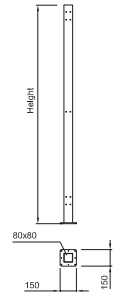
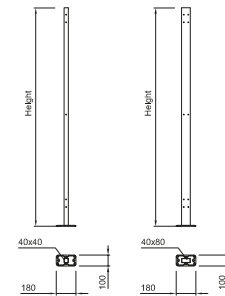
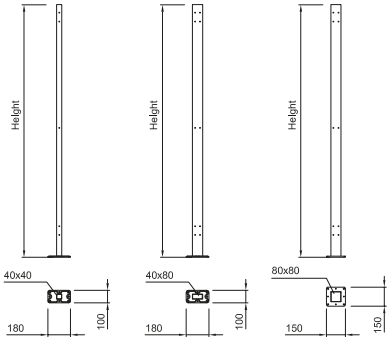

COMMERCIAL CODE	TECHNICAL CODE	Height	Section	Plate	Weight (kg)
MT112	0020024#03000001	1600	40x40	100x180	4,00
MT113	0020024#05000001	2000	40x40	100x180	5,00
MT501	0020024#03010001	1600	40x80	100x180	6,70
MT502	0020024#05010001	2000	40x80	100x180	7,70
MT506	7020001952	3110	40x80	100x180	11,50
MT212	0020024#03020001	1600	80x80	150x150	8,90
MT213	0020024#05020001	2000	80x80	150x150	10,70
MT217	6020001953	3110	80x80	150x150	16,00
MT704	7020004993	2000	50x50	100x180	6,5
MT707	7020004996	3110	50x50	100x180	9,75

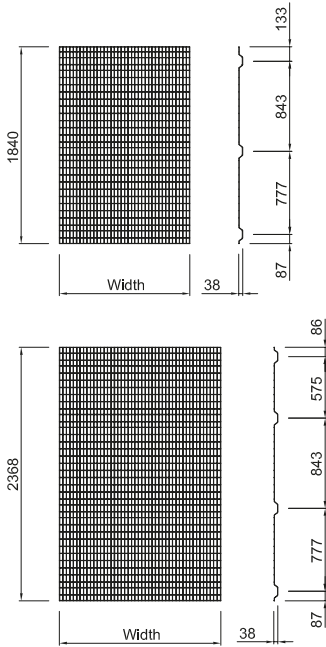

COMMERCIAL CODE	TECHNICAL CODE	Width	Height	Weight (kg)
PNNT001	0020101#0224110100	259	1840	1,40
PNNT002	0020101#0324110100	419		2,00
PNNT003	0020101#0424110100	707		3,60
PNNT004	0020101#0524110100	1027		5,00
PNNT005	0020101#0724110100	1219		6,00
PNNT006	0020101#0824110100	1507		7,40
PNNT013	0020101#6124110100	2019		9,85
PNNT008	0020101#0226110100	259	2368	1,90
PNNT009	0020101#0326110100	419		2,60
PNNT010	0020101#0426110100	707		4,30
PNNT011	0020101#0526110100	1027		6,00
PNNT012	0020101#0726110100	1219		7,20
PNNT007	0020101#0826110100	1507		9,00

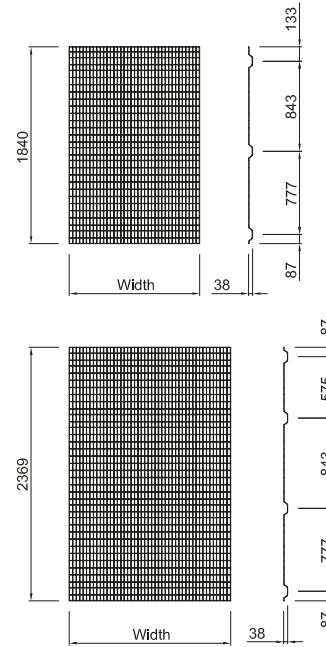

COD.	TECHNICAL CODE	Width	Height	Weight (kg)
PNNT116	0020106#0824140100	260	1840	2,11
PNNT117	0020106#1324140100	420		3,41
PNNT118	0020106#2724140100	708		5,75
PNNT110	0020106#3724140100	1028		8,36
PNNT115	0020106#4324140100	1220		9,89
PNNT120	0020106#5224140100	1508		12,20
PNNT125	0020106#6824140100	2020		16,29
PNNT130	0020106#8324140100	2500	20,13	
PNNT121	0020106#0830140100	260	2369	2,69
PNNT122	0020106#1330140100	420		4,35
PNNT123	0020106#2730140100	708		7,33
PNNT204	0020106#3730140100	1028		10,65
PNNT205	0020106#4330140100	1220		12,64
PNNT206	0020106#5230140100	1508		15,63

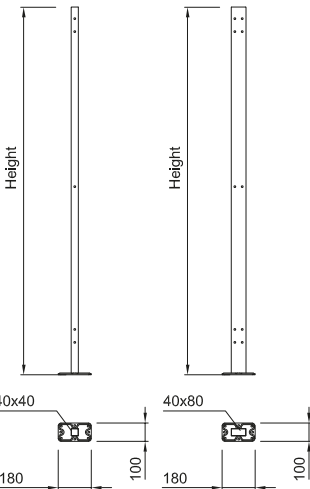

COMMERCIAL CODE	TECHNICAL CODE	Height	Section	Plate	Weight (kg)
MT113	0020024#05000001	2000	40x40	100x180	5,00
MATEC110	0020029#05000001	2000	40x40	100x180	5,00
MT2500	0020024#43000001	2520	40x40	100x180	6,00
MATEC2500	0020029#43000001	2520	40x40	100x180	6,00
MT502	0020024#05010001	2000	40x80	100x180	7,70
MATEC115	0020029#05010001	2000	40x80	100x180	7,70
MT507	0020024#43010001	2520	40x80	100x180	8,70
MATEC2501	0020029#43010001	2520	40x80	100x180	8,70
MT300	0020024#05140001	2000	50x50	100x180	6,50
MATEC301	0020029#05140001	2000	50x50	100x180	6,50
MT350	0020024#43140001	2520	50x50	100x180	8,02
MATEC351	0020029#43140001	2520	50x50	100x180	8,02

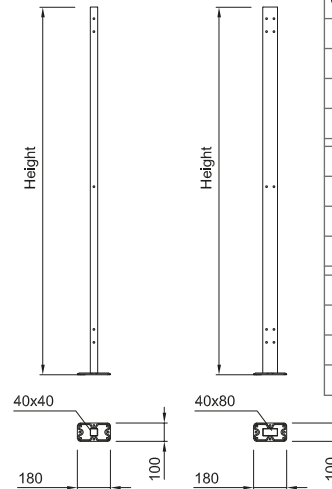

COMMERCIAL CODE	TECHNICAL CODE	Height	Section	Plate	Weight (kg)
MT113	0020024#05000001	2000	40x40	100x180	5,00
MATEC110	0020029#05000001	2000	40x40	100x180	5,00
MT2500	0020024#43000001	2520	40x40	100x180	6,00
MATEC2500	0020029#43000001	2520	40x40	100x180	6,00
MT502	0020024#05010001	2000	40x80	100x180	7,70
MATEC115	0020029#05010001	2000	40x80	100x180	7,70
MT507	0020024#43010001	2520	40x80	100x180	8,70
MATEC2501	0020029#43010001	2520	40x80	100x180	8,70
MT300	0020024#05140001	2000	50x50	100x180	6,5
MATEC301	0020029#05140001	2000	50x50	100x180	6,5
MT350	0020024#43140001	2520	50x50	100x180	8,023
MATEC351	0020029#43140001	2520	50x50	100x180	8,023

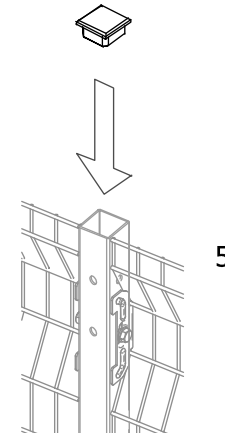
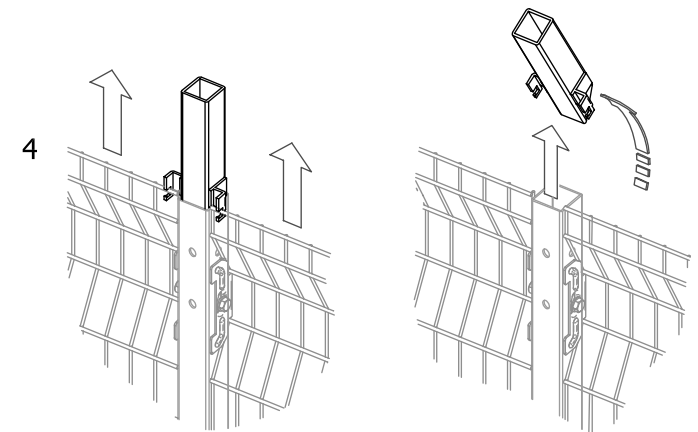
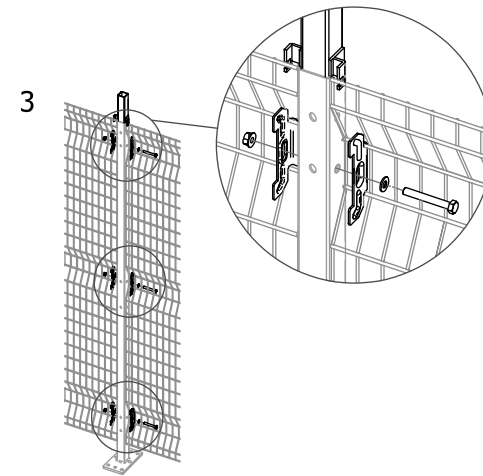
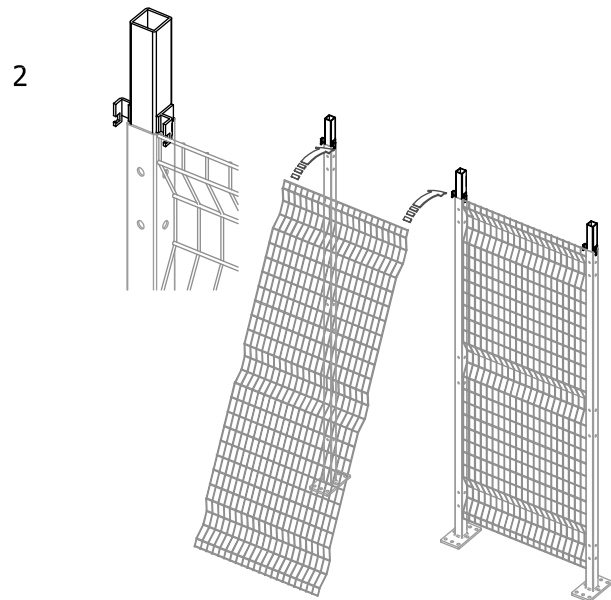
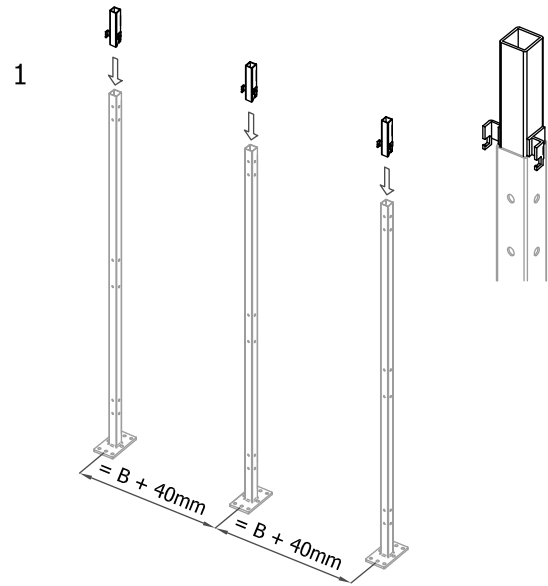

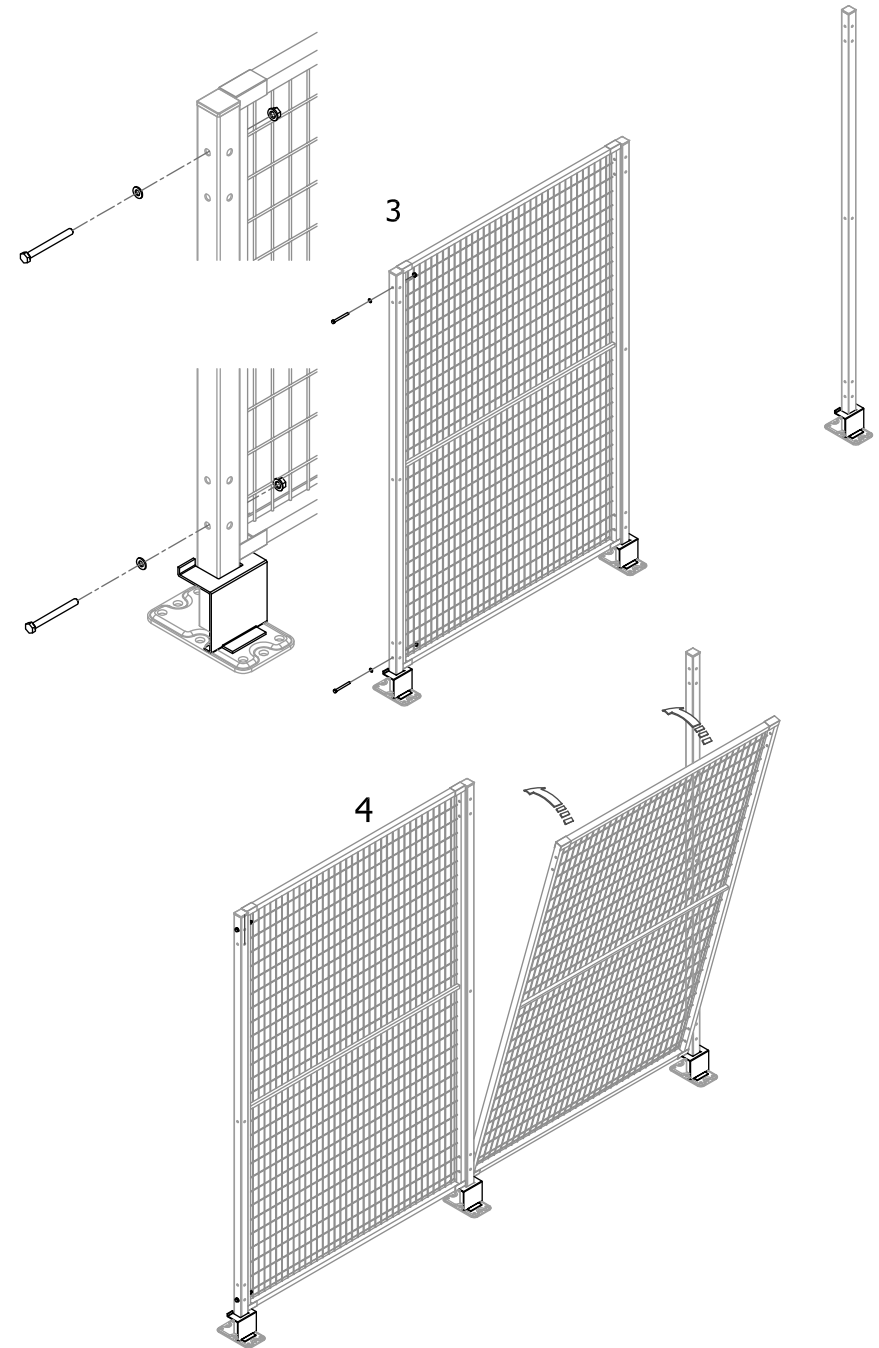
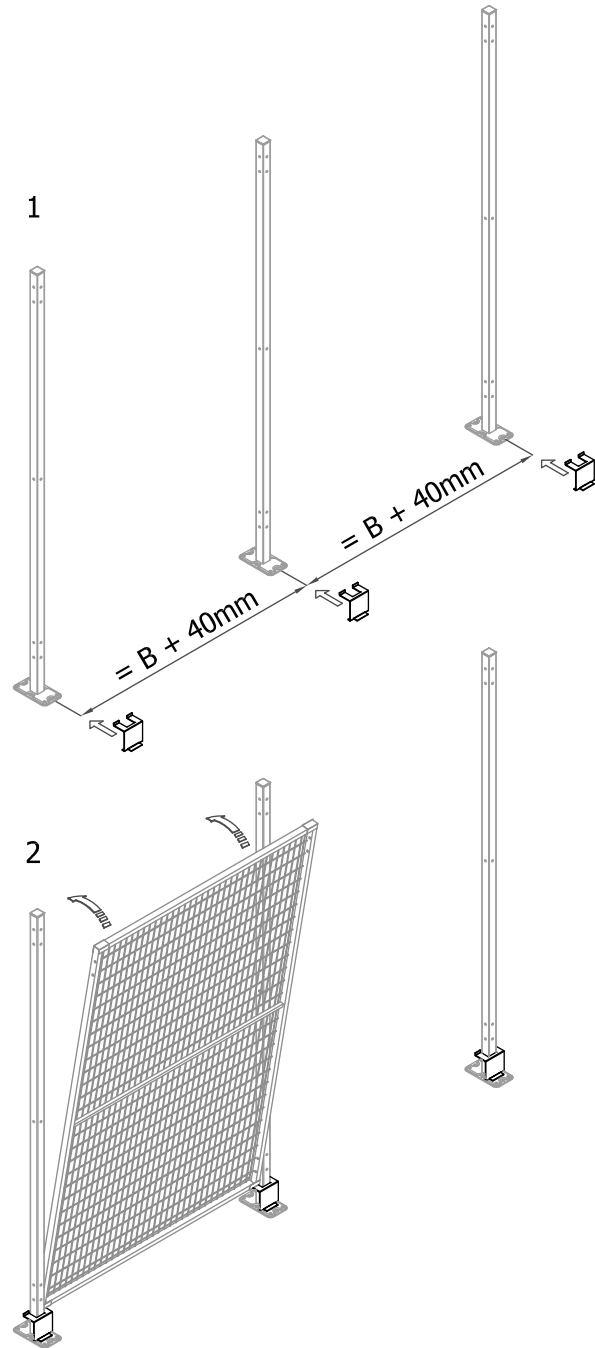





M10	Nm = 25	
M8	Nm = 15	

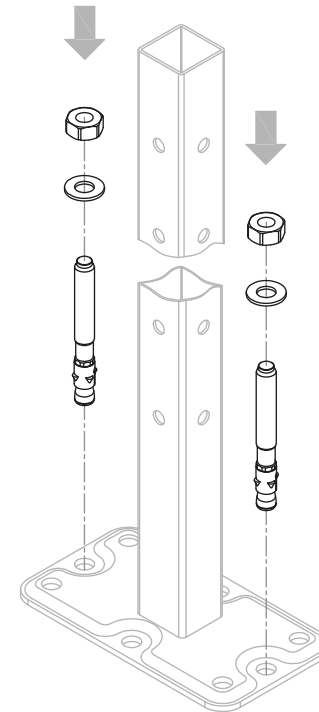
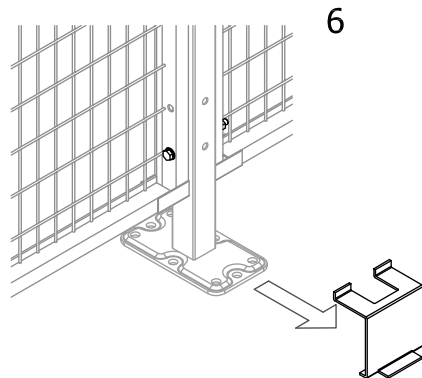
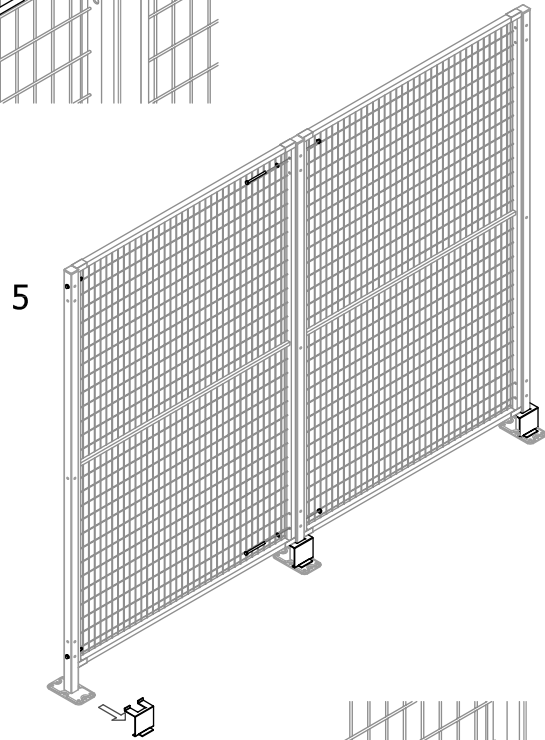
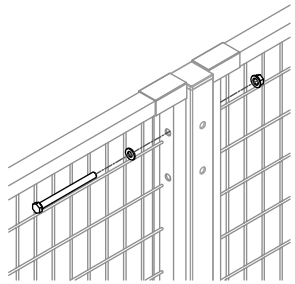

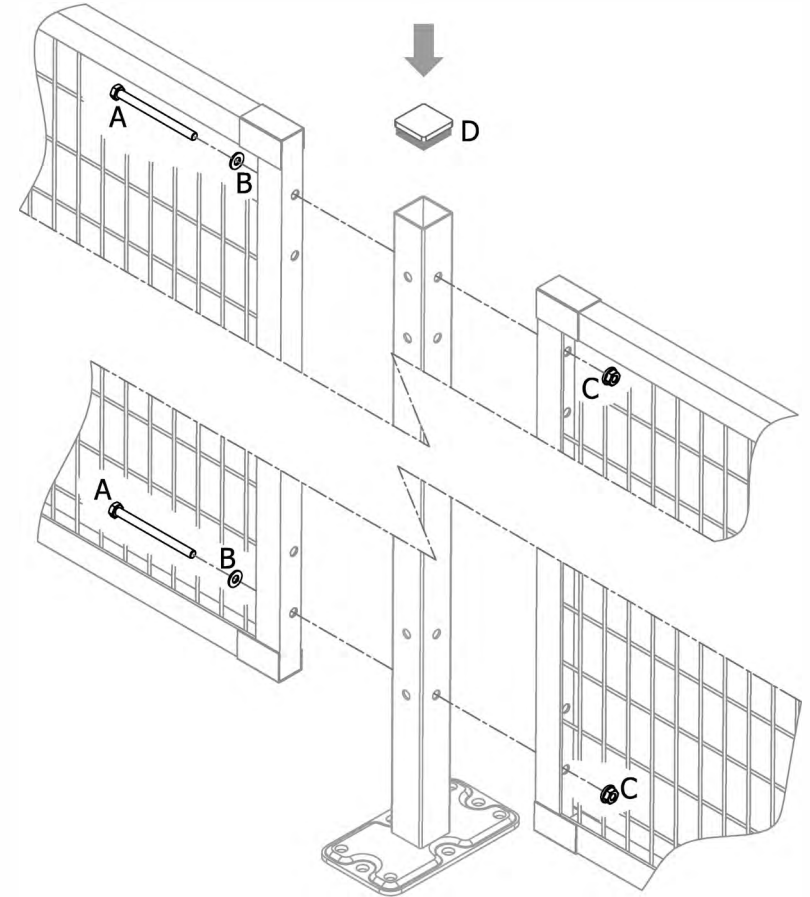
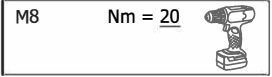
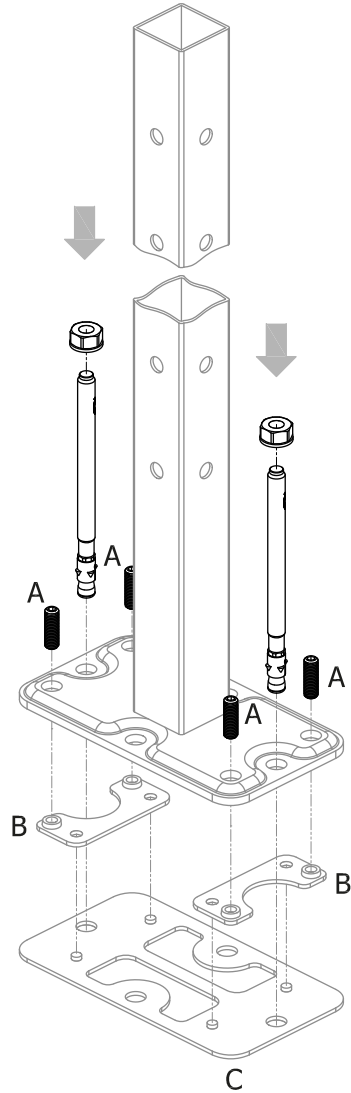
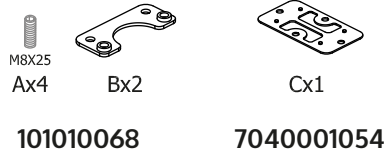

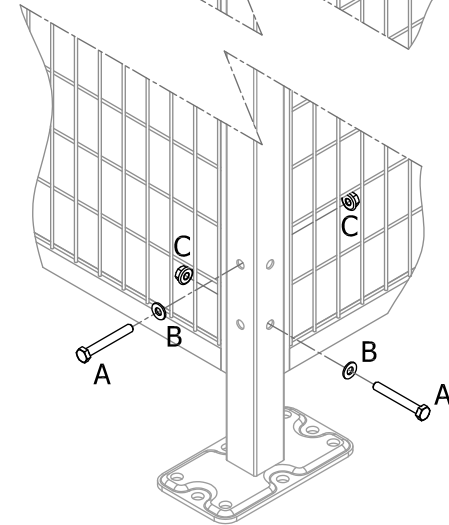
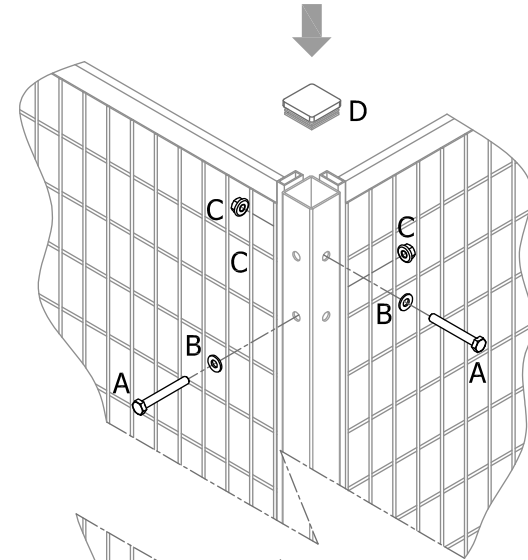
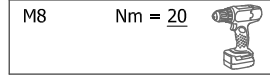
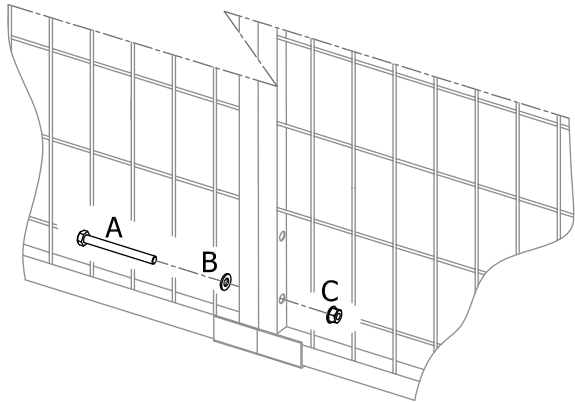
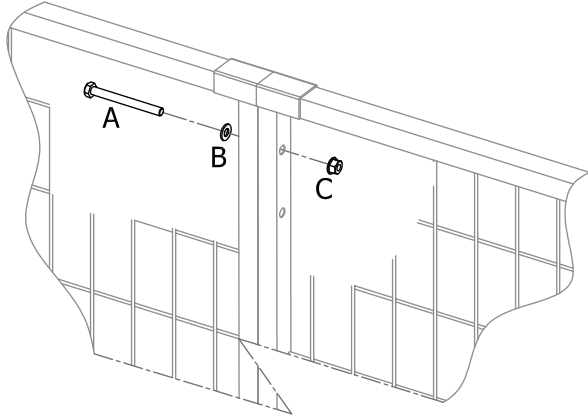
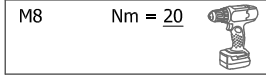

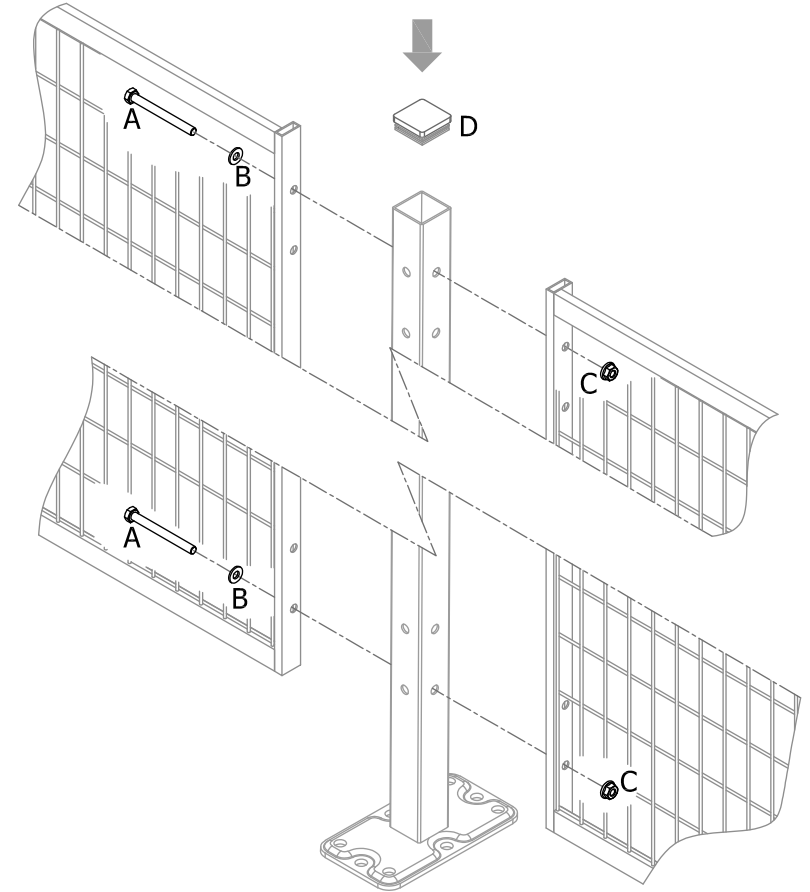
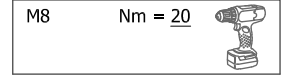
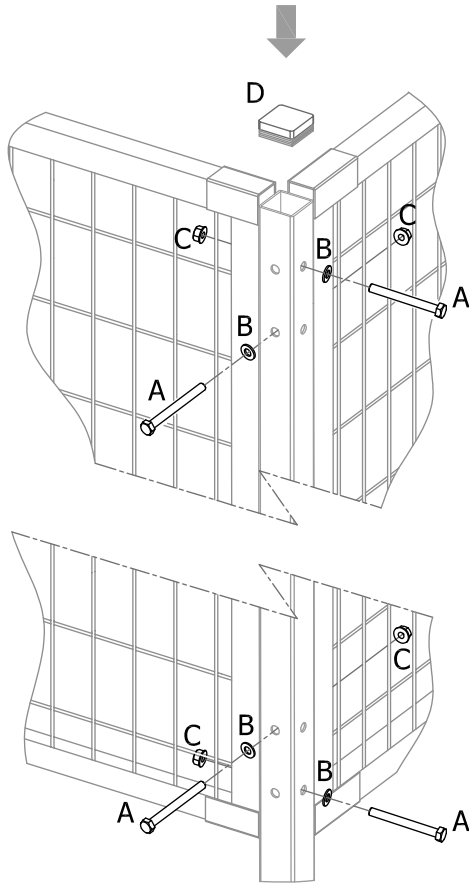
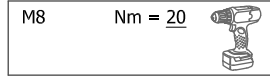

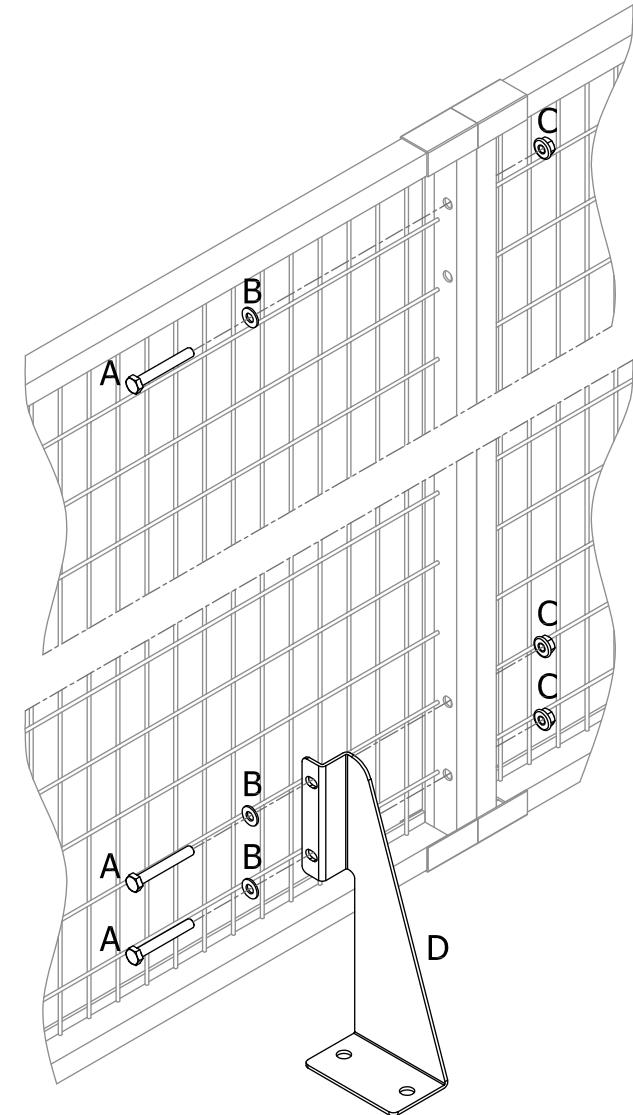
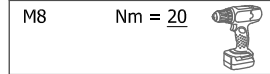
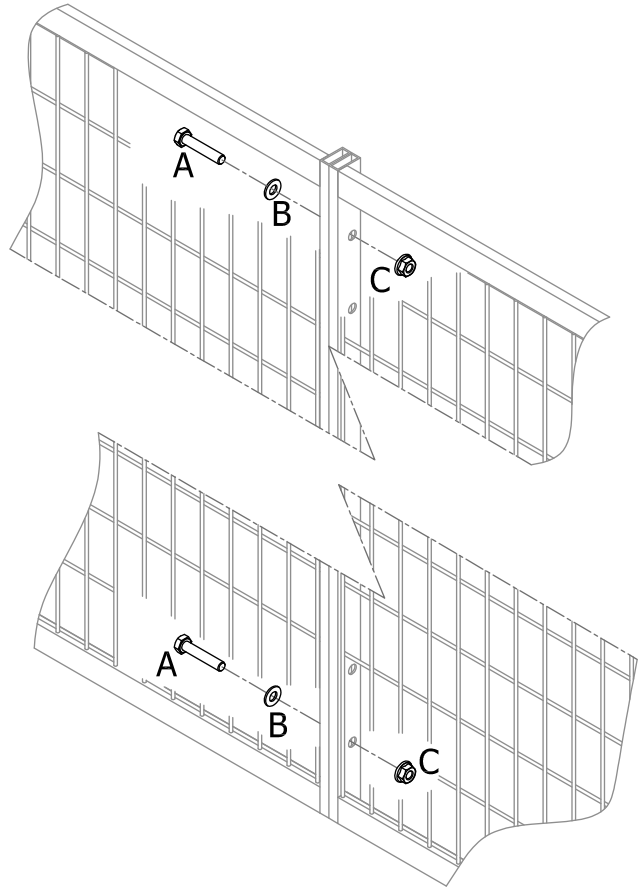
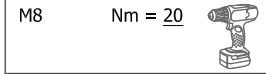

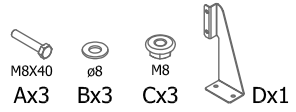



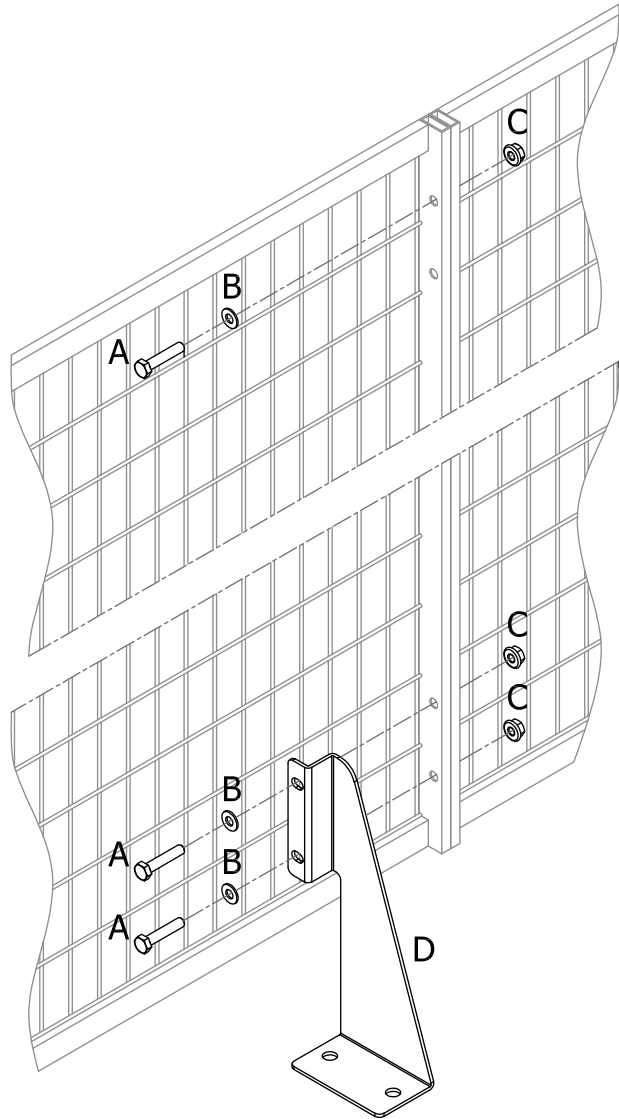

M8 Nm = 20 



M8 Nm = 20 

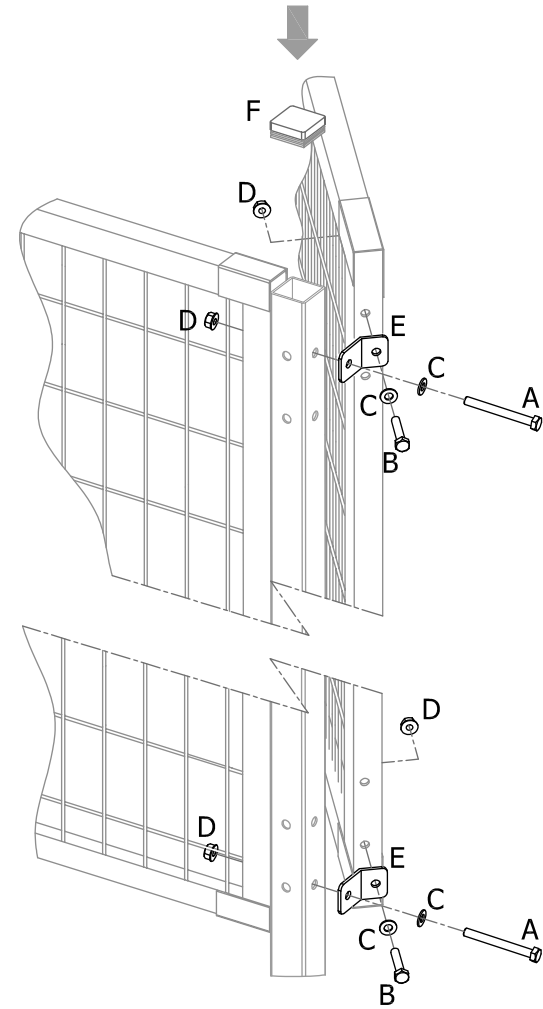

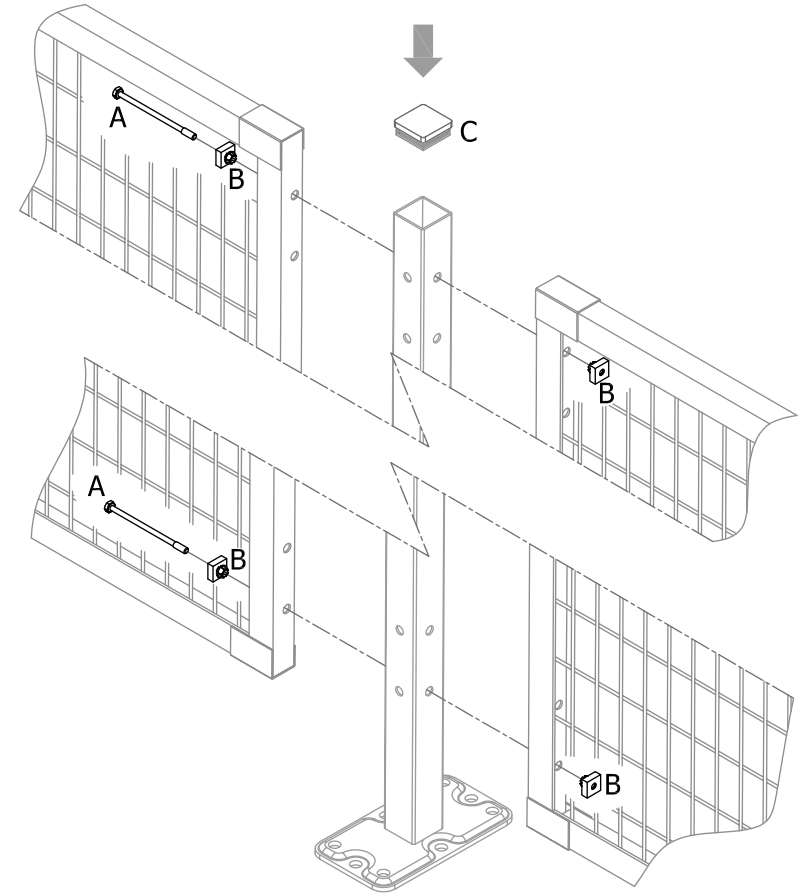
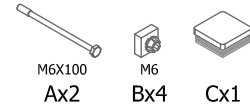
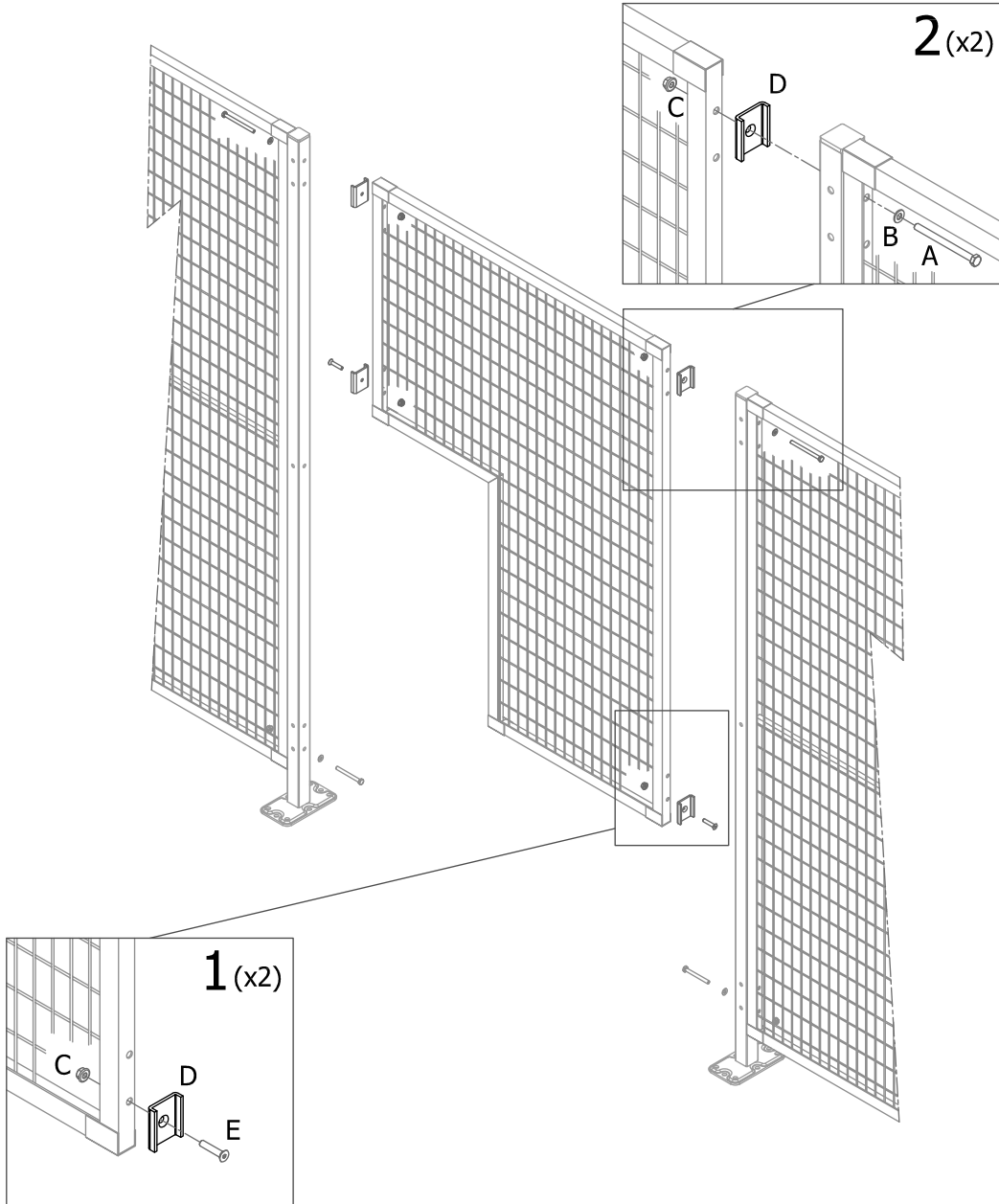
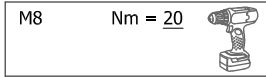

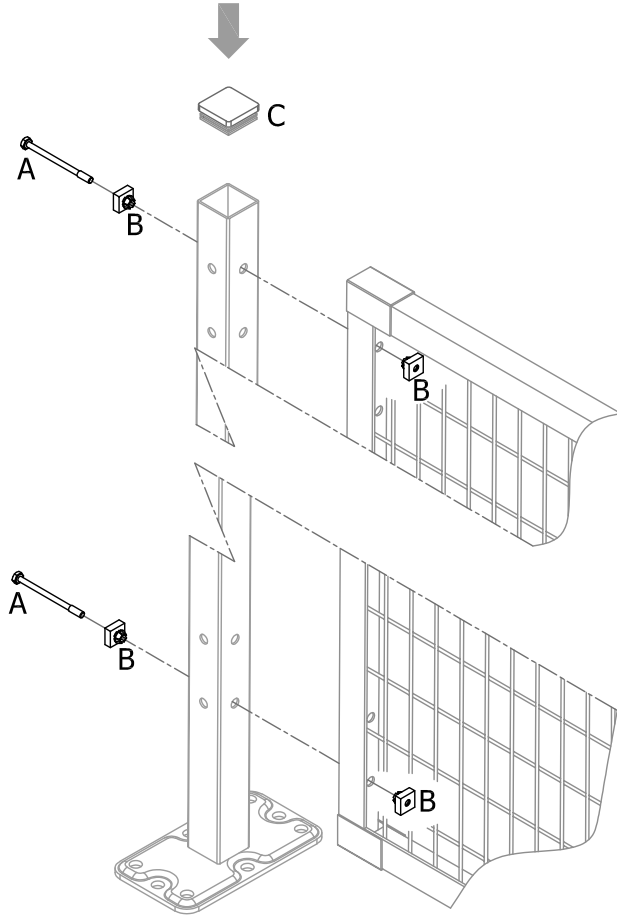

101010104C

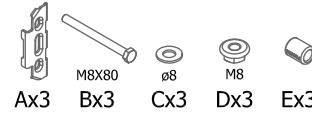

101010107C

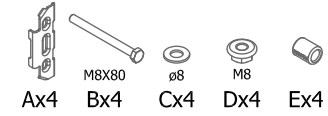

M8 Nm = 20

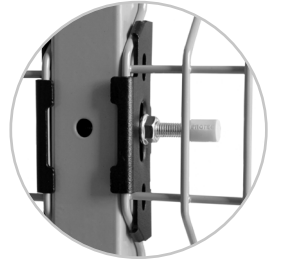
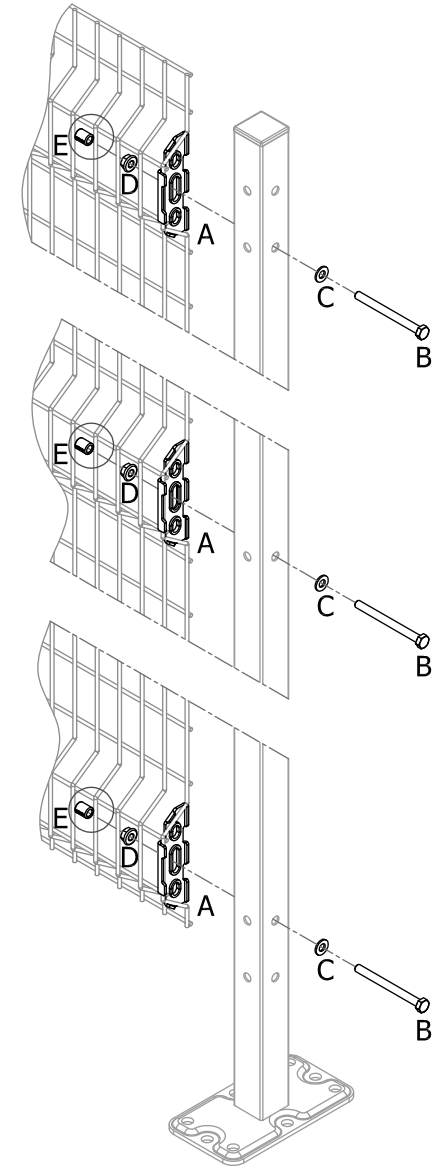



101010103C

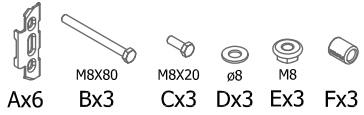

101010106C



M8(B) Nm = 20  
M8(C) Nm = 7±8

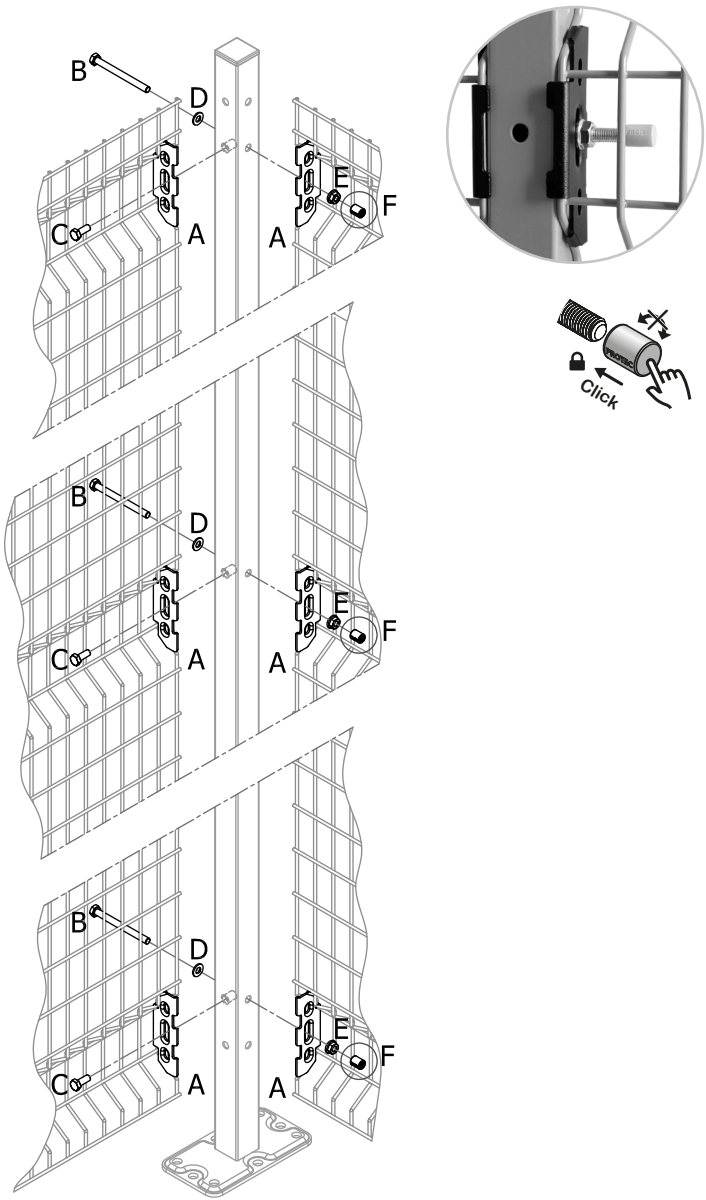

101010102C

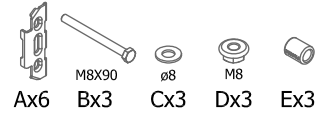

101010105C

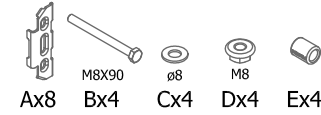

M8 Nm = 20

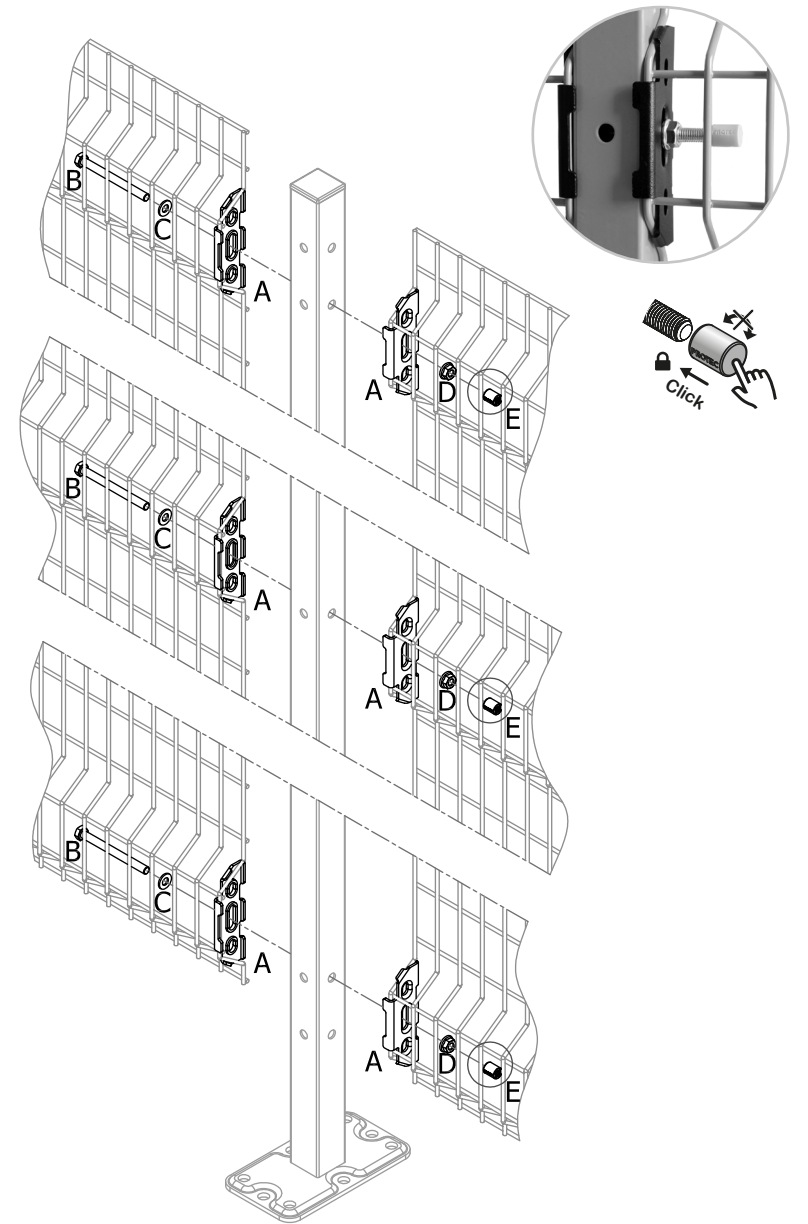

101010042C

101010079C



Ax3



Ax4



M8x30

x4



ø8

x4

M8	Nm = 7÷8	
----	----------	--

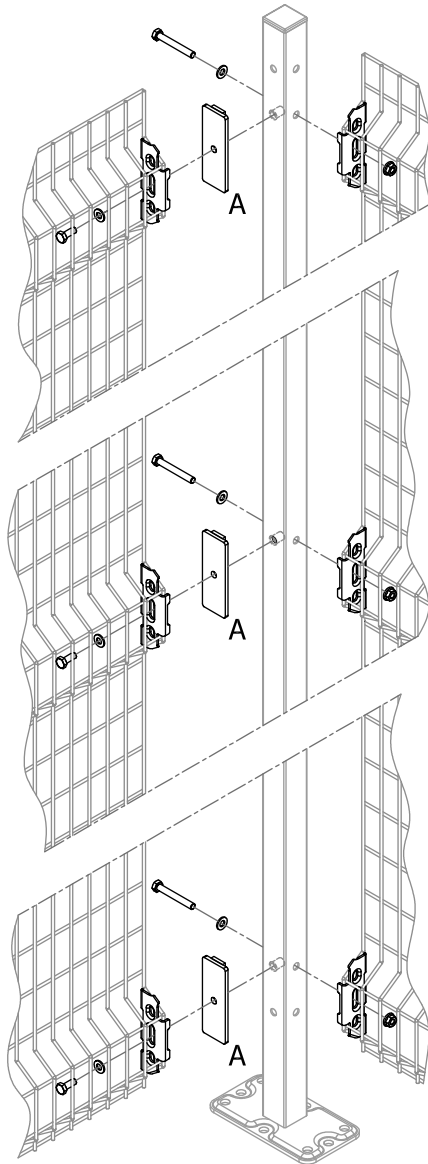

101010043C

101010061C



Ax3



M8x60

Bx3



M8x20

Cx3



M8

Dx3



Ax4



M8x60

Bx4



M8x20

Cx4



M8

Dx4

M8(B)	Nm = 20	
M8(C)	Nm = 7÷8	

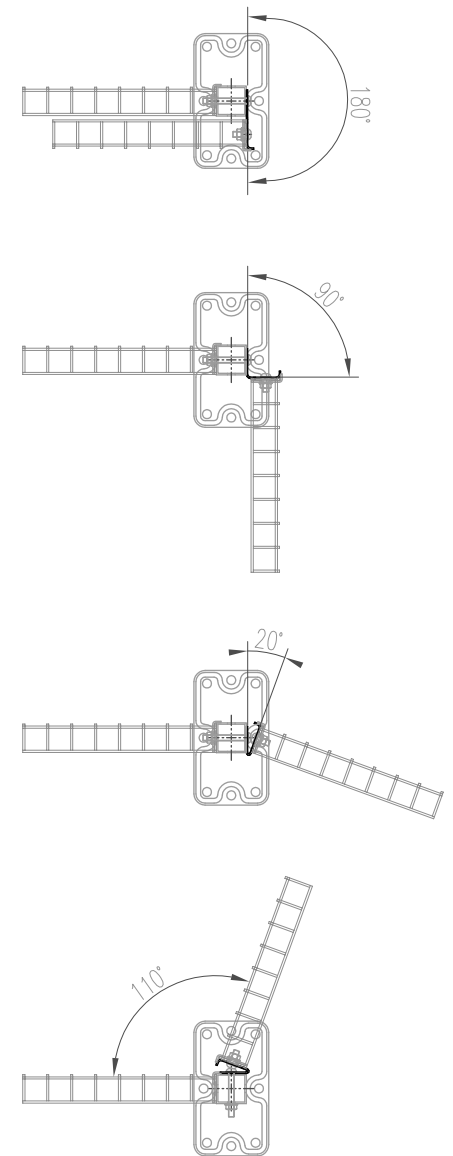
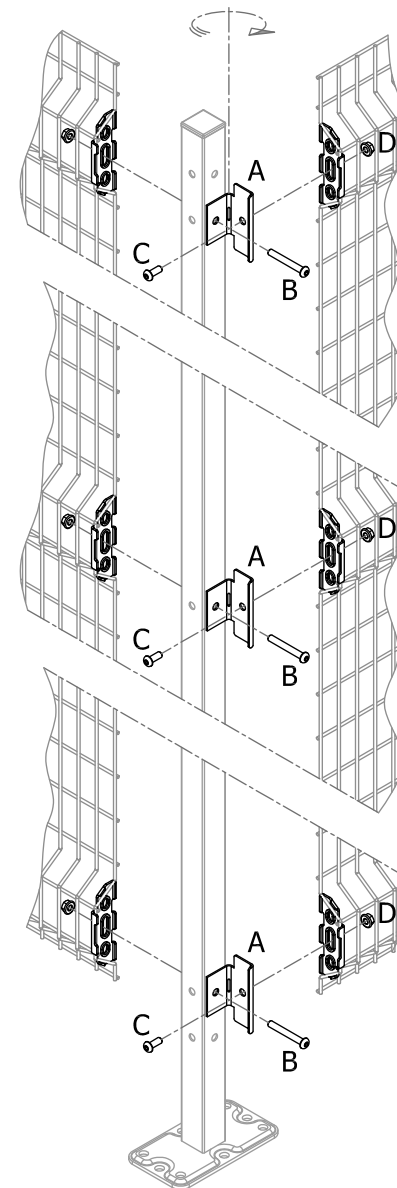

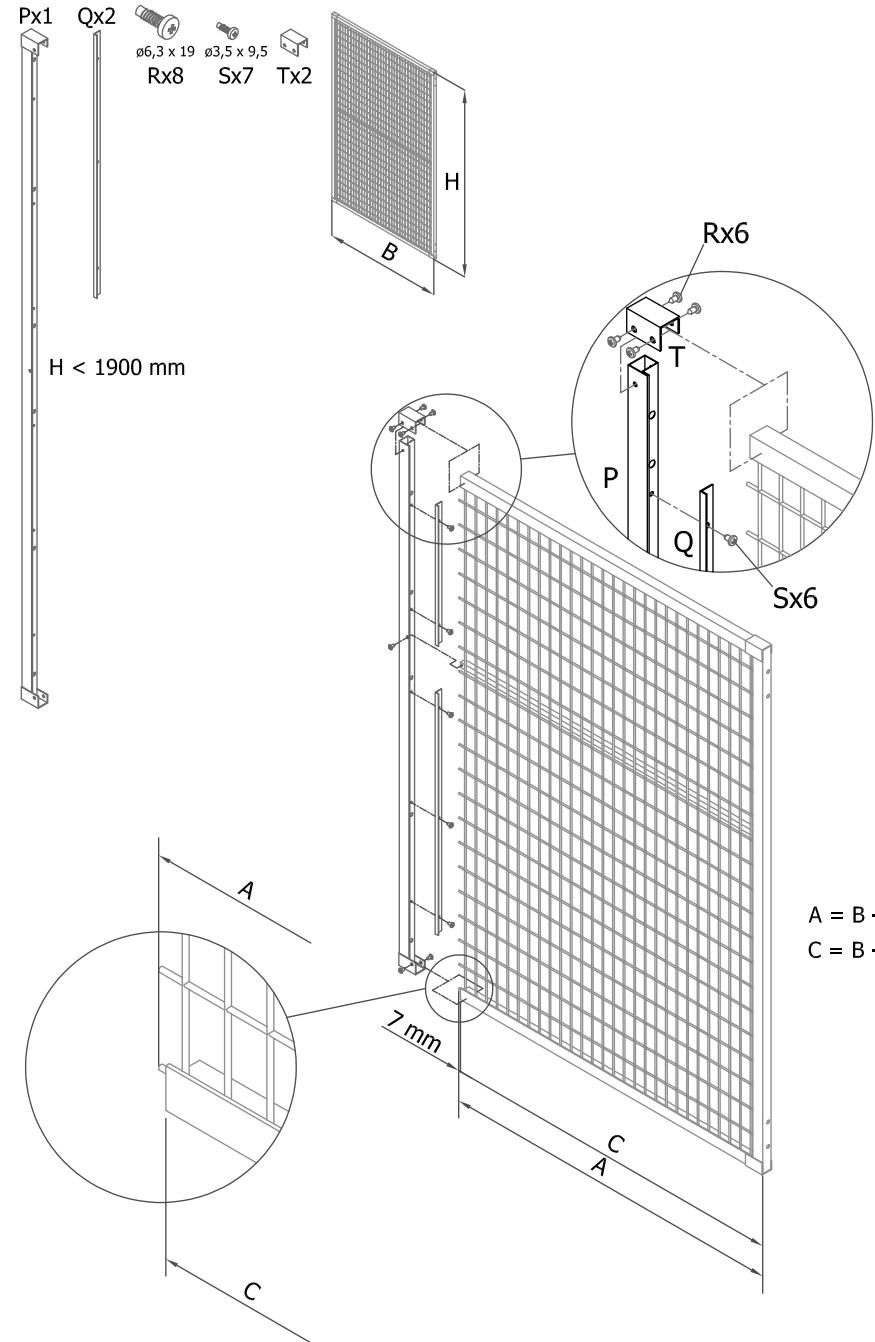
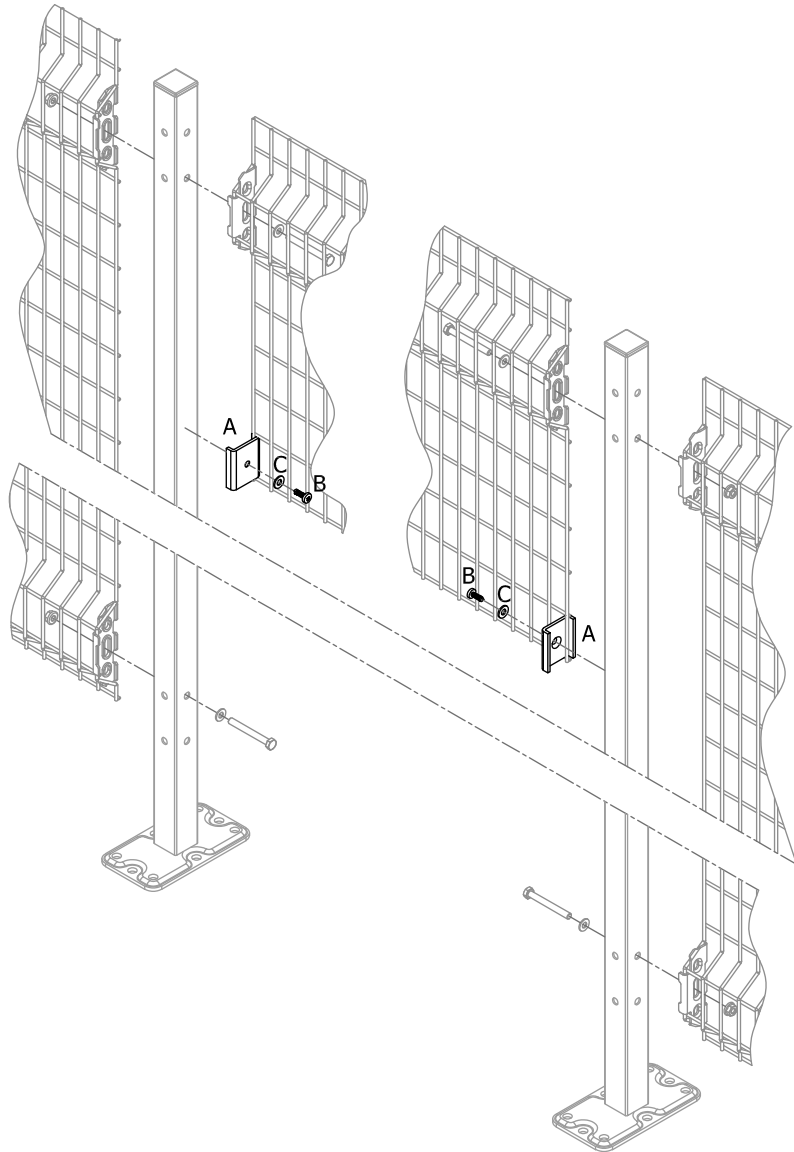
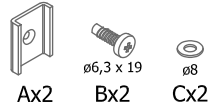

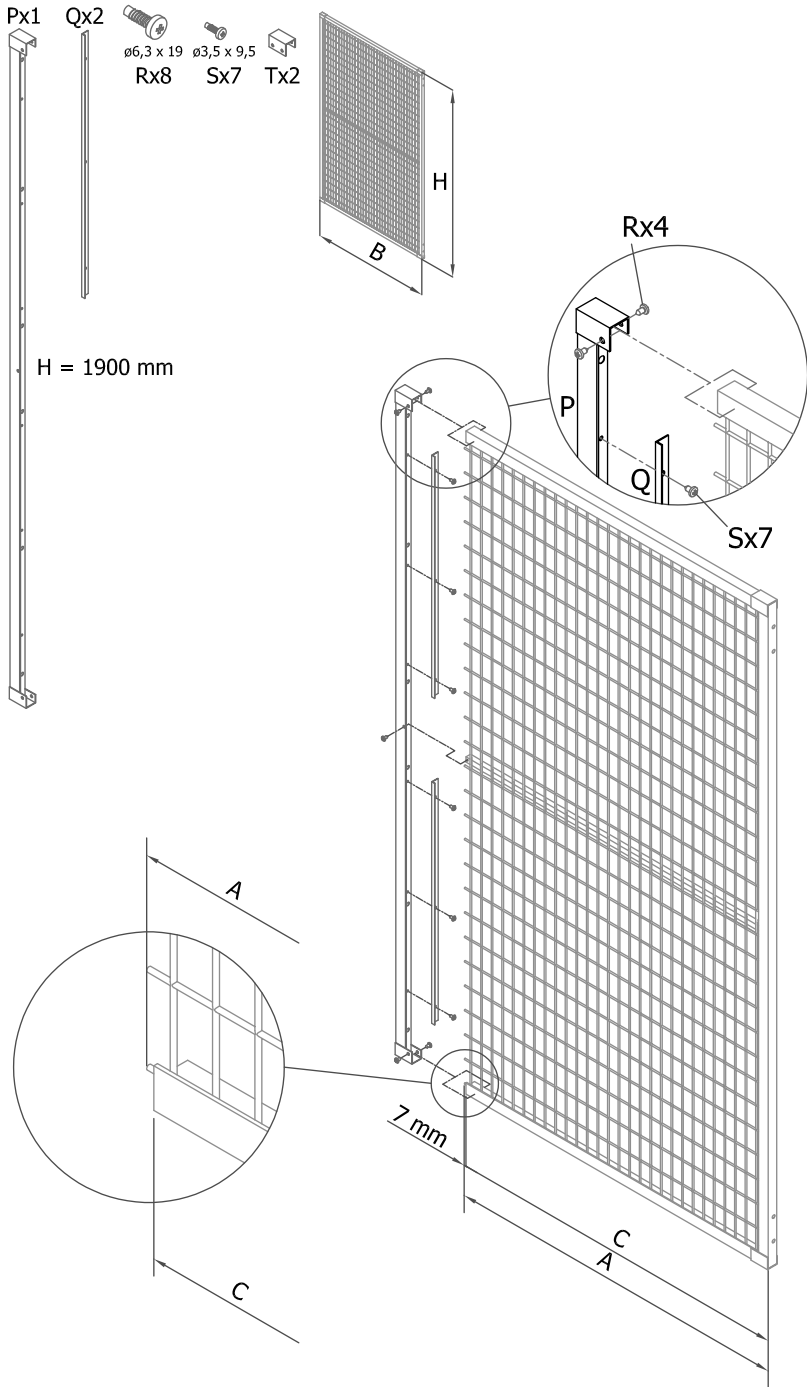

$A = B - 25 \text{ mm}$   
 $C = B - 32 \text{ mm}$

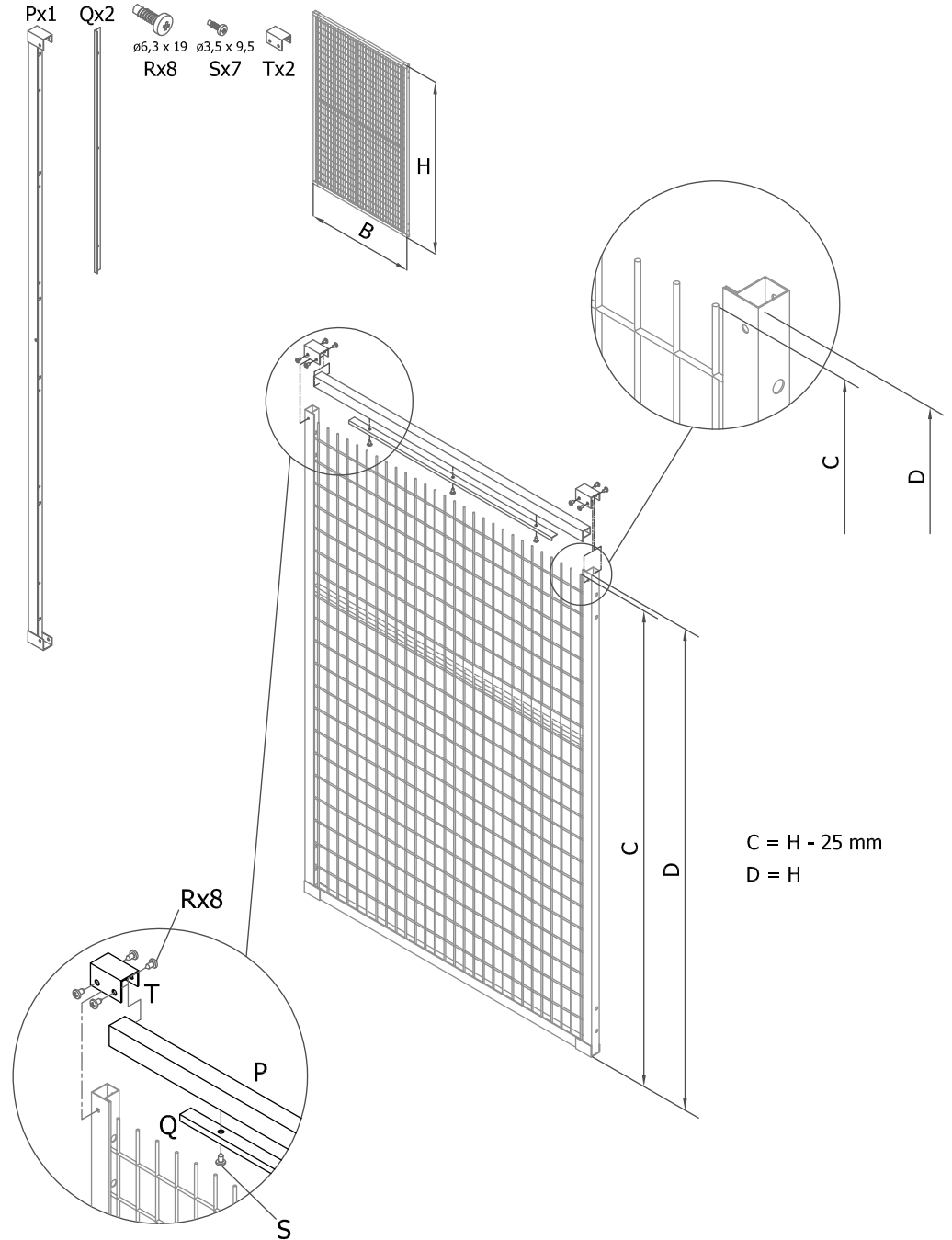

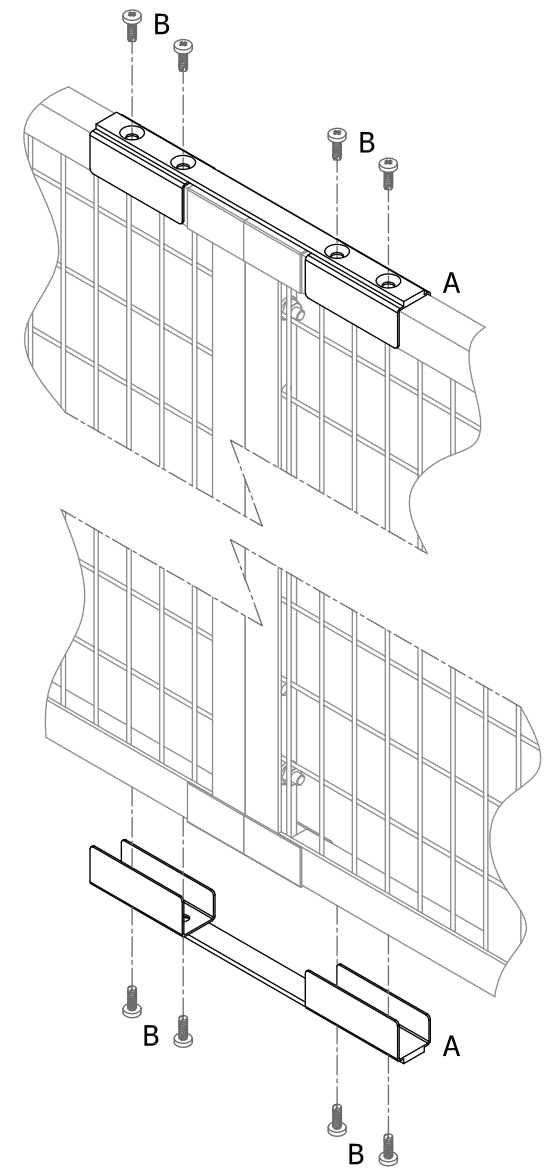
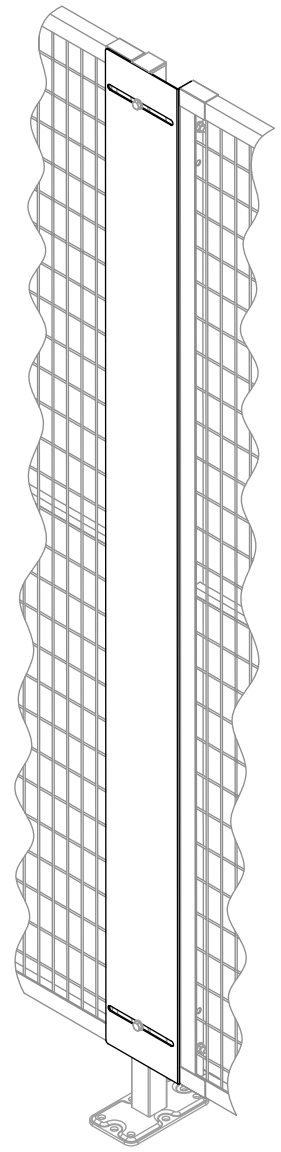
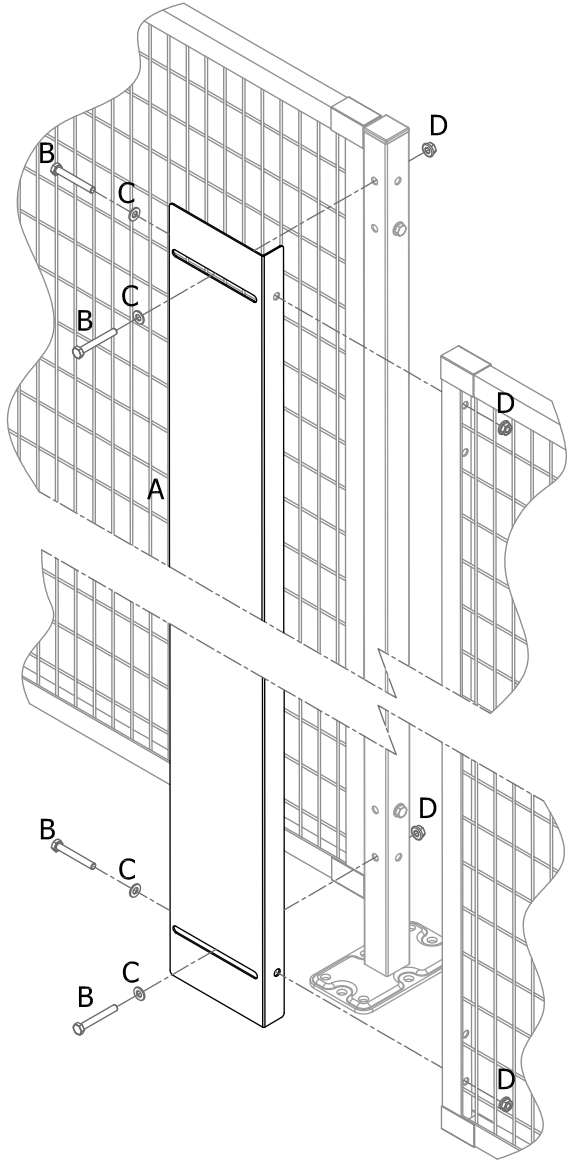
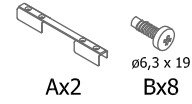
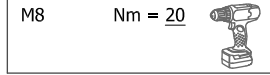
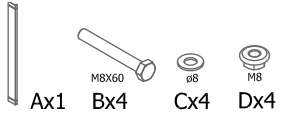

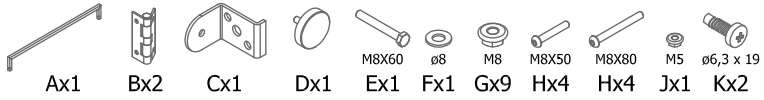

M8(E,H,N)	Nm = 20	
M8(O)	Nm = 7±8	
M5	Nm = 5	

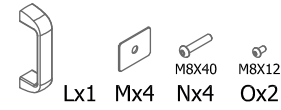
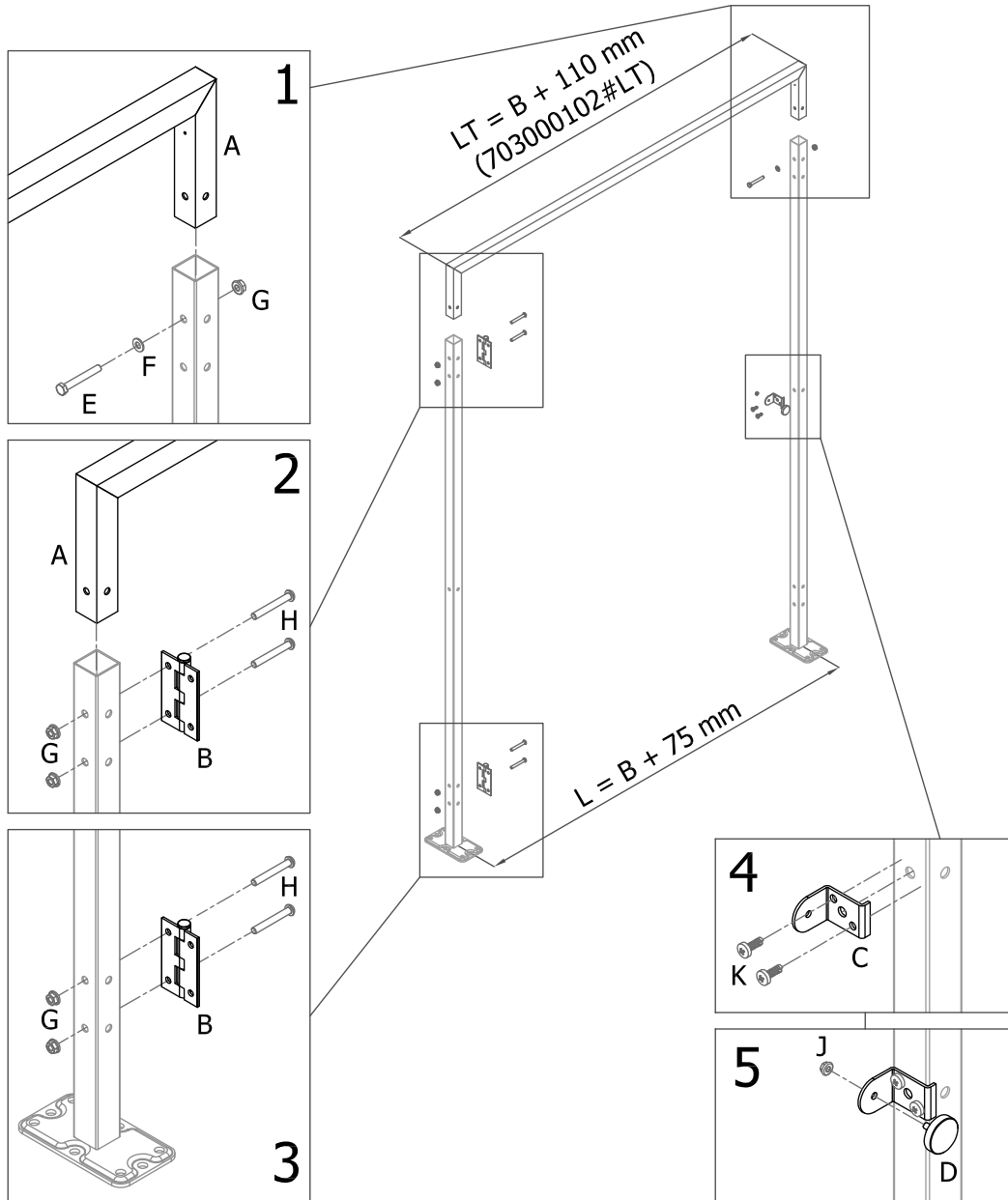

M8(E,H,N)	Nm = 20	
M8(O)	Nm = 7±8	
M5	Nm = 5	

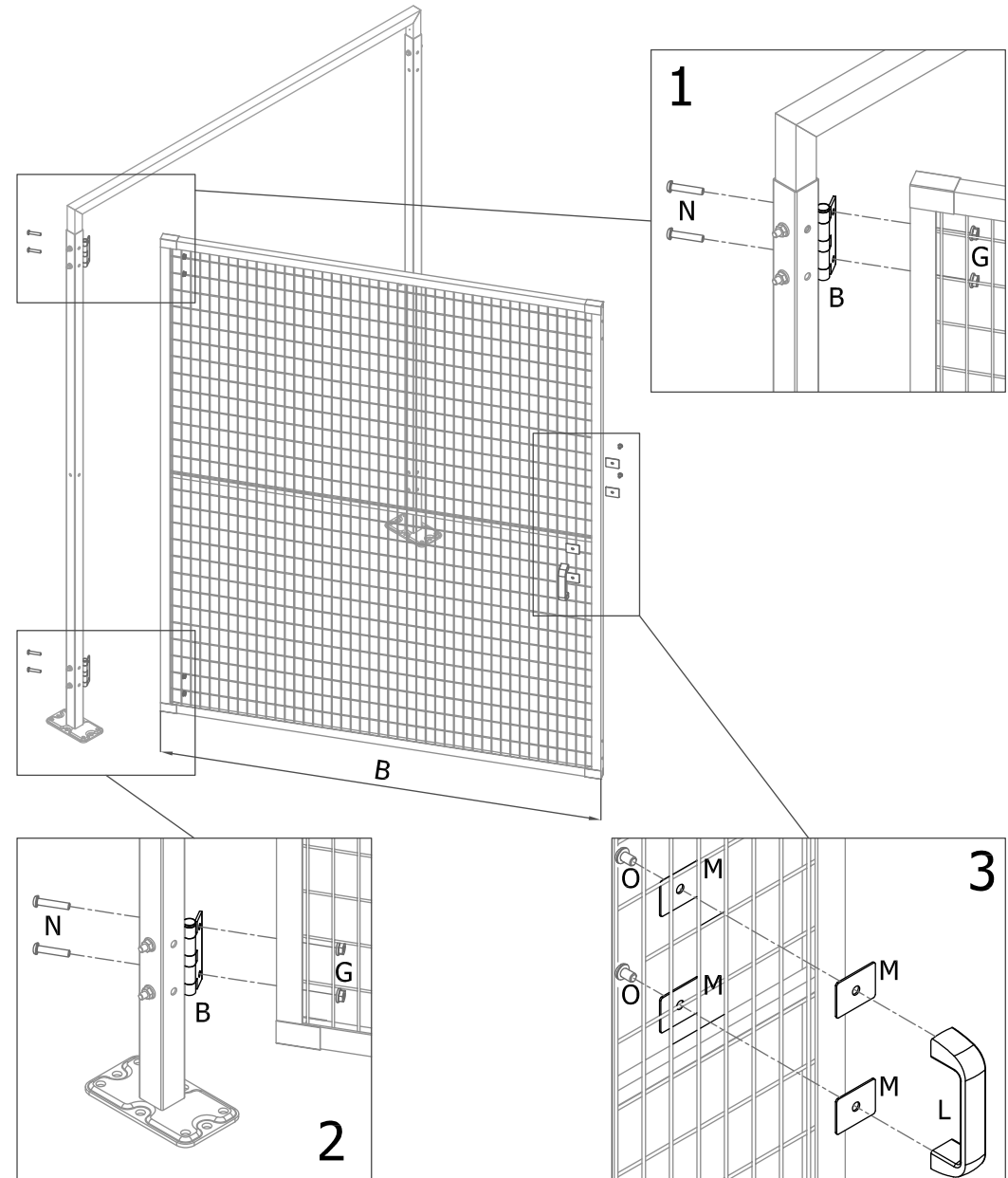



M8(C,E,O)	Nm = 20	
M8(N)	Nm = 7±8	
M5	Nm = 5	

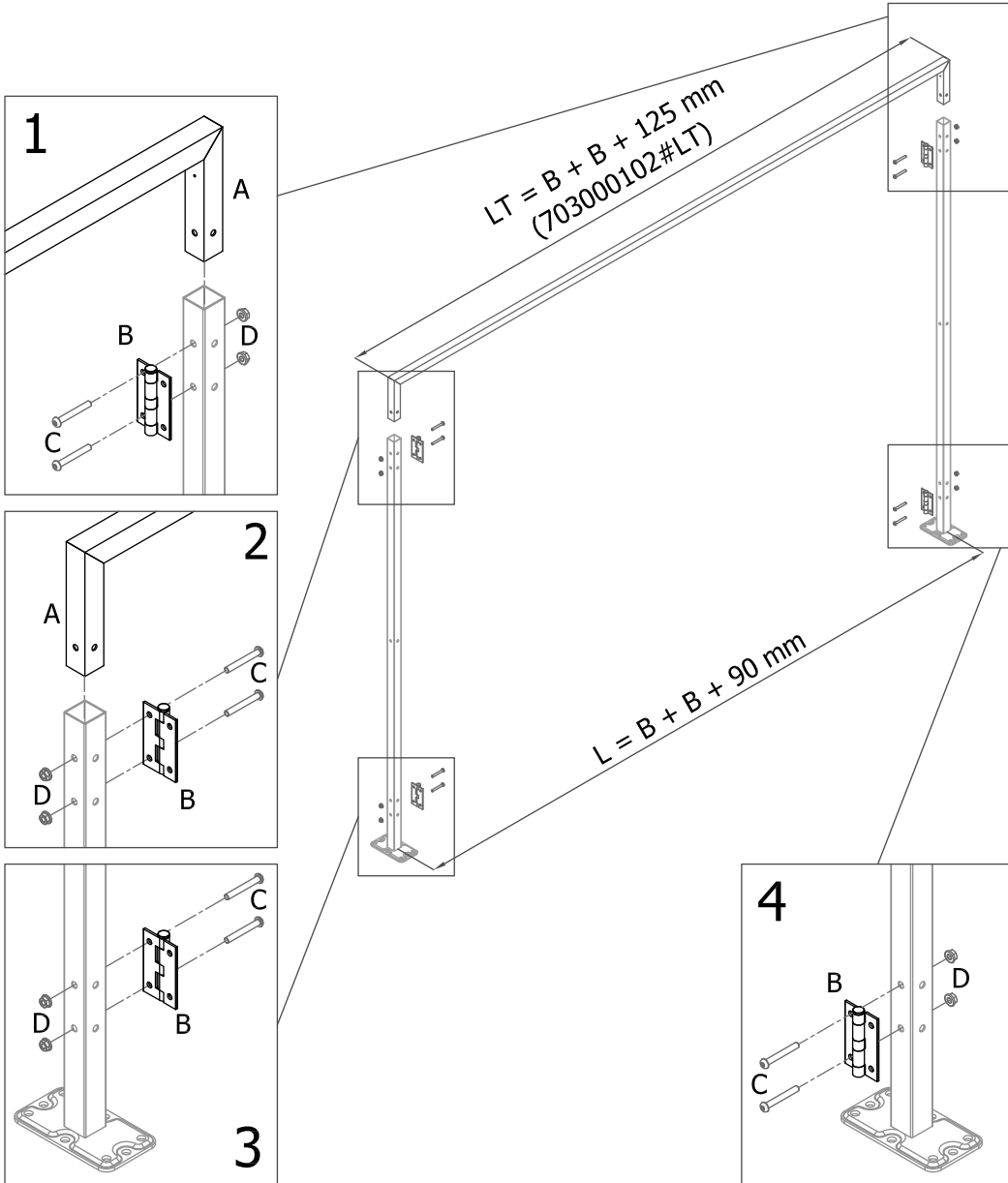

M8(C,E,O)	Nm = 20	
M8(N)	Nm = 7±8	
M5	Nm = 5	

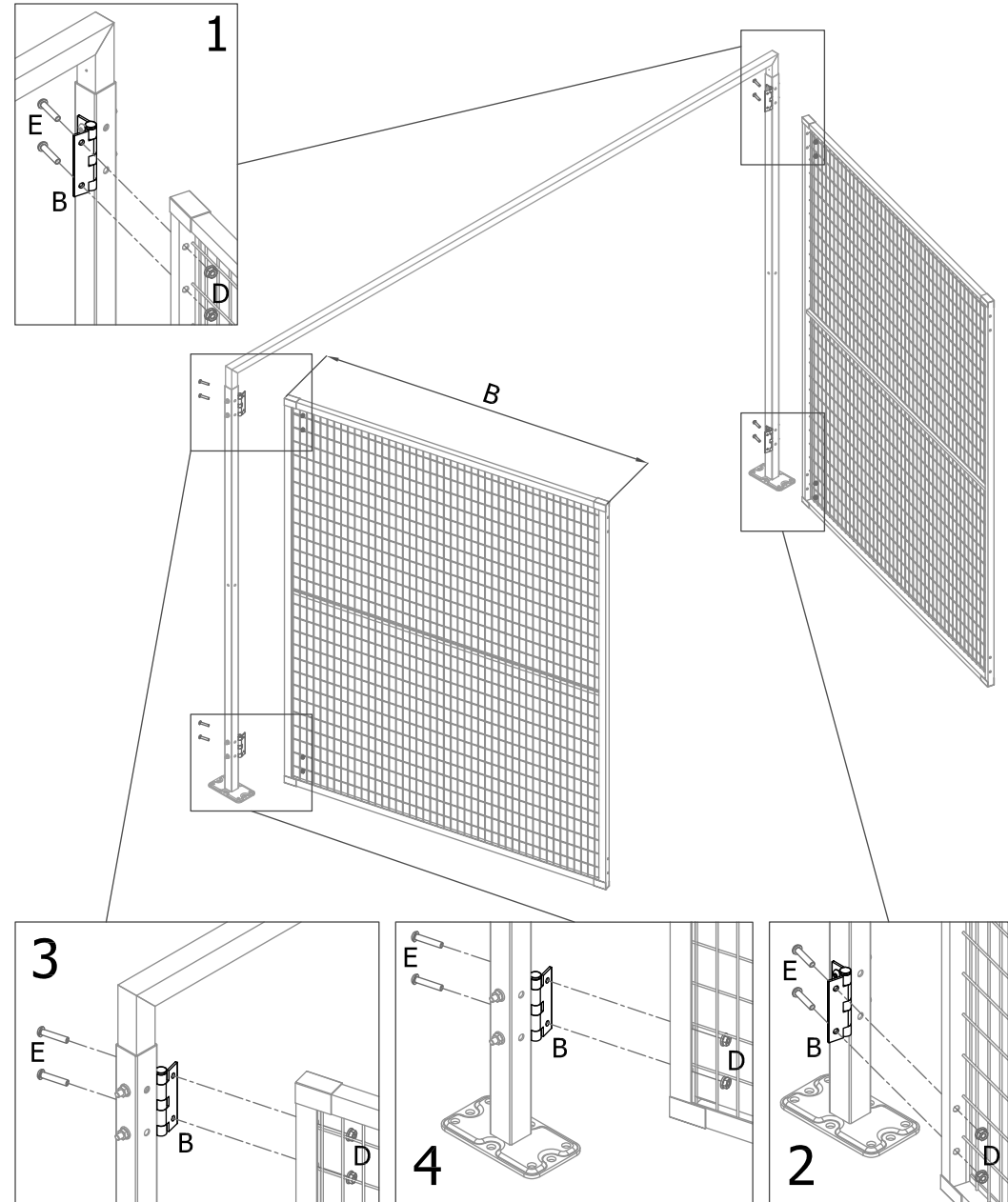

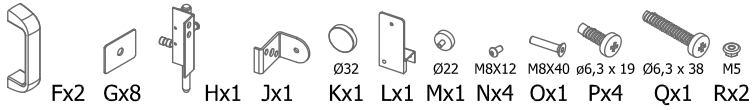

M8(C,E,O)	Nm = 20	
M8(N)	Nm = 7±8	
M5	Nm = 5	

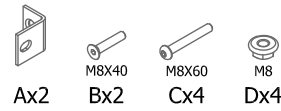
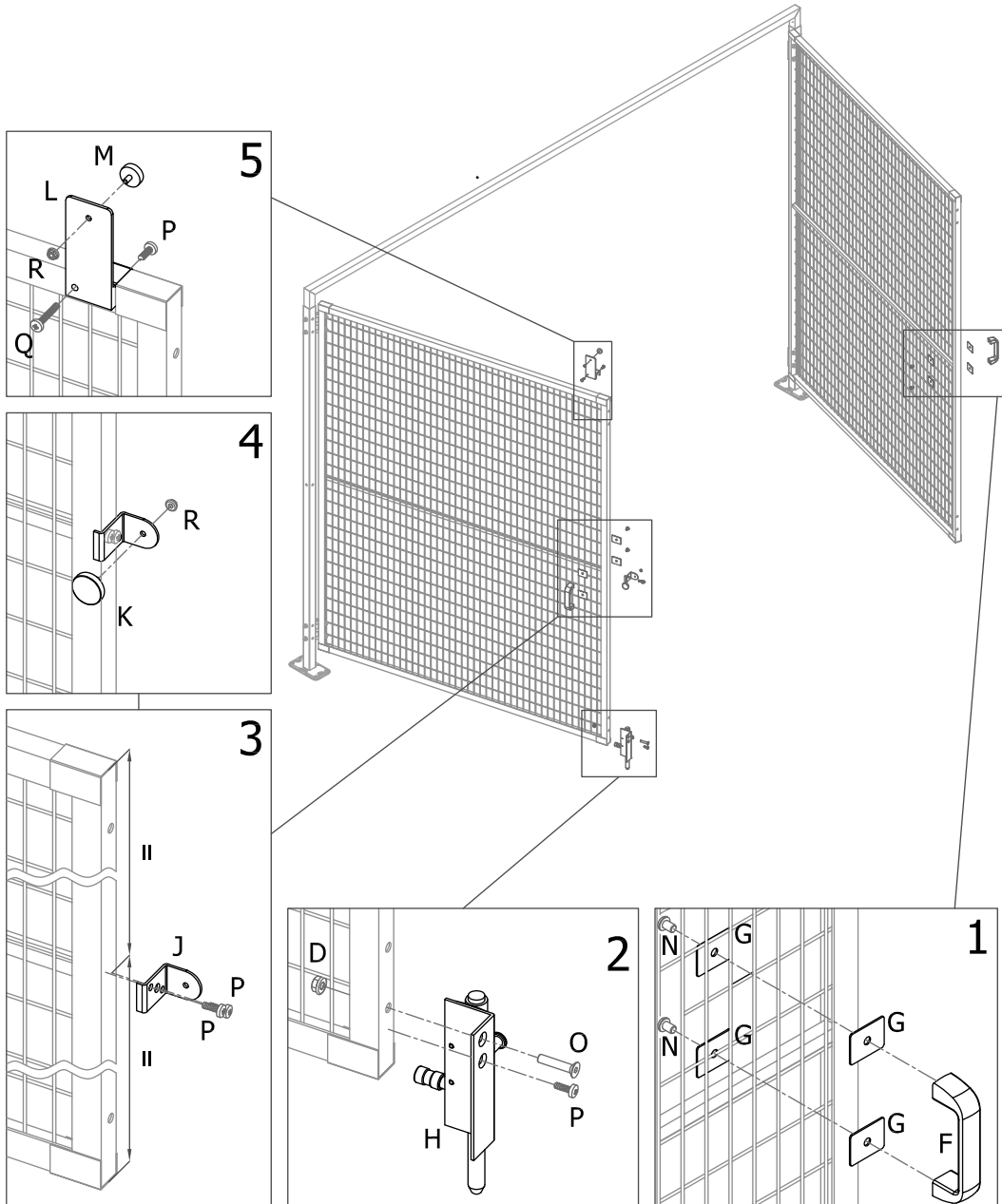

M8	Nm = 20	
----	---------	--

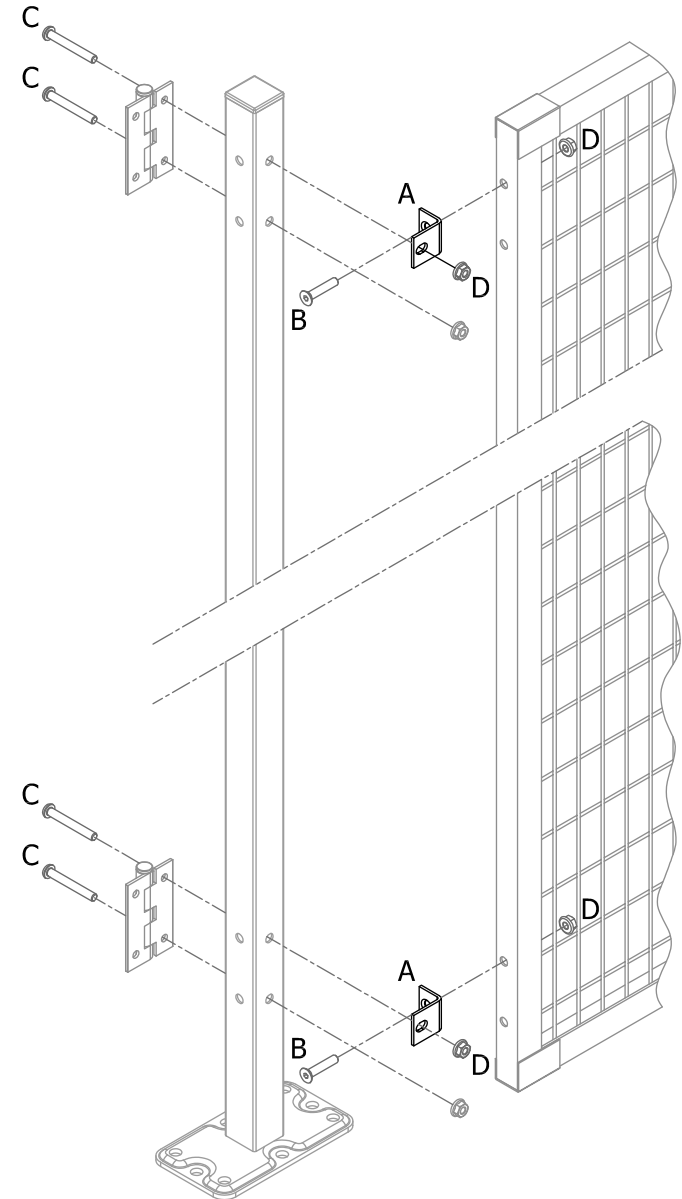



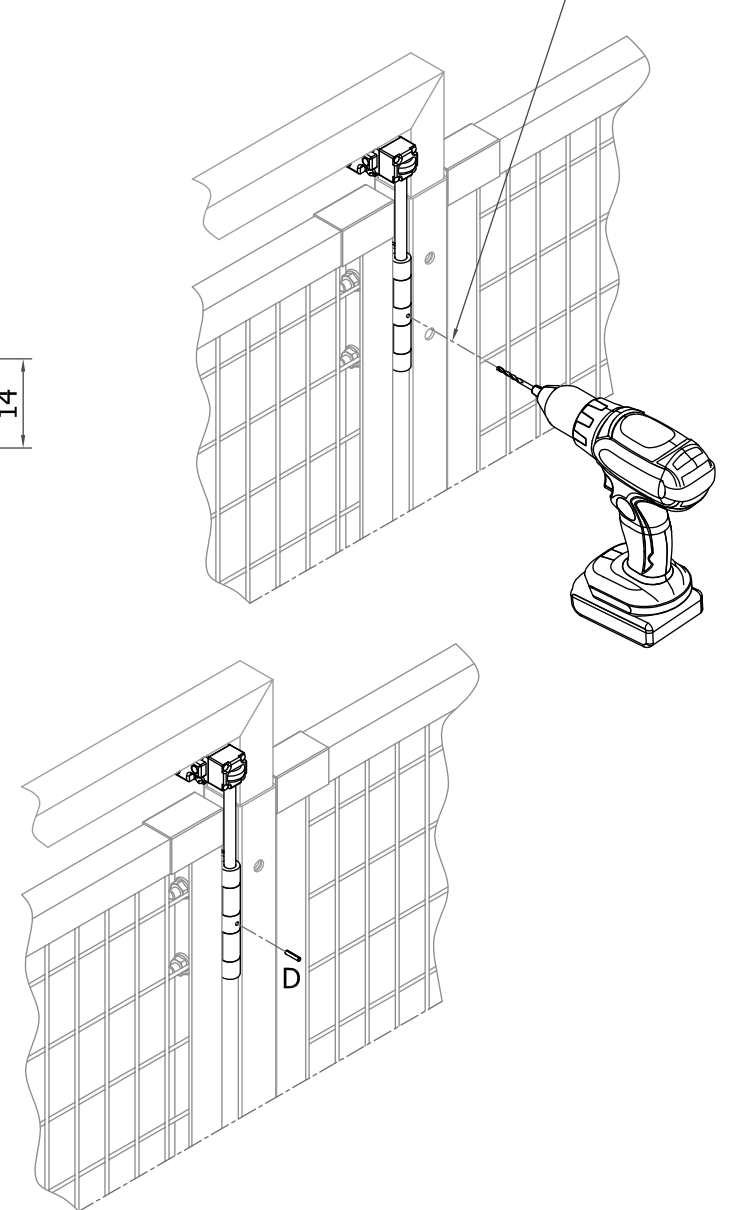
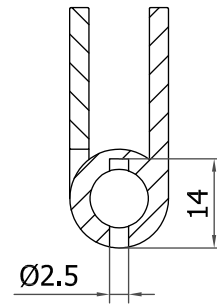
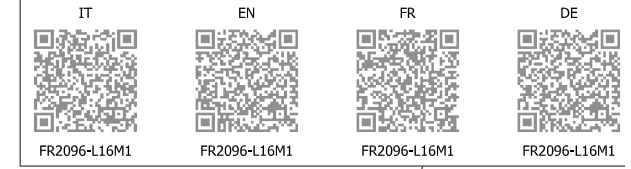
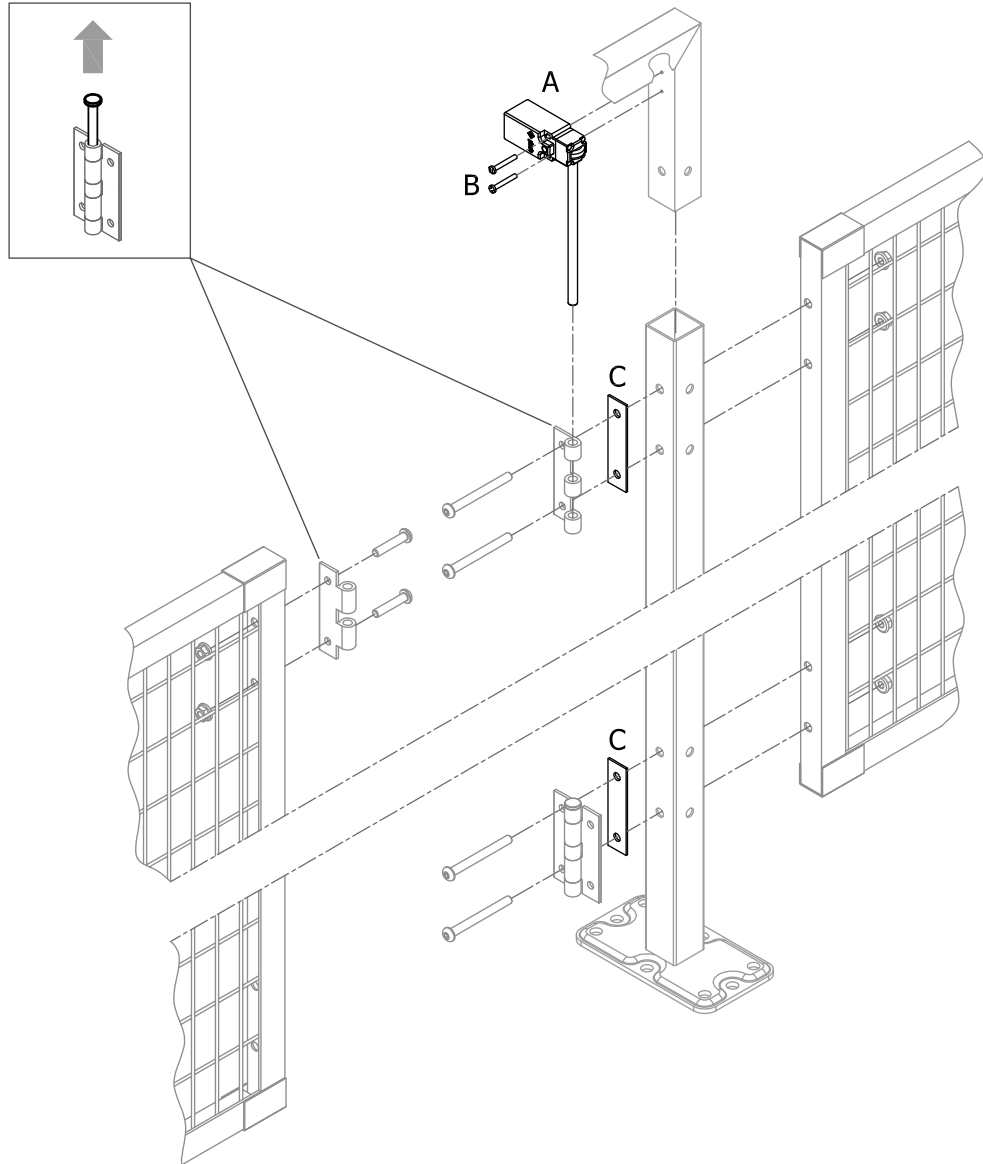
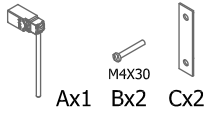

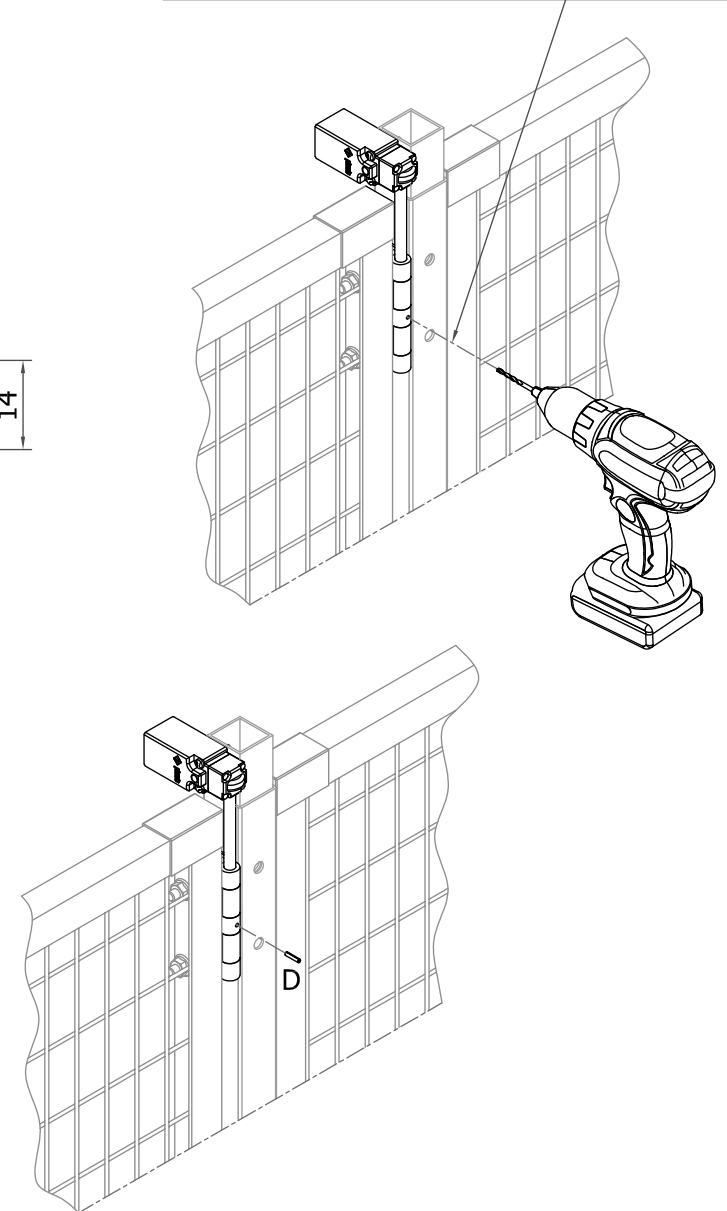
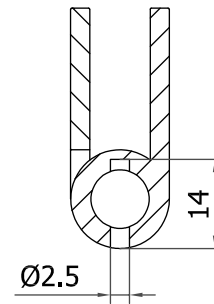
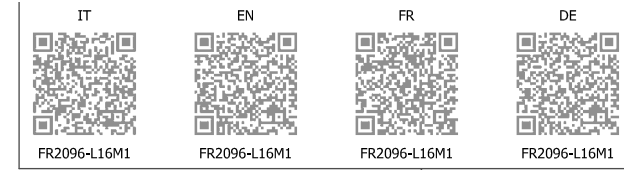
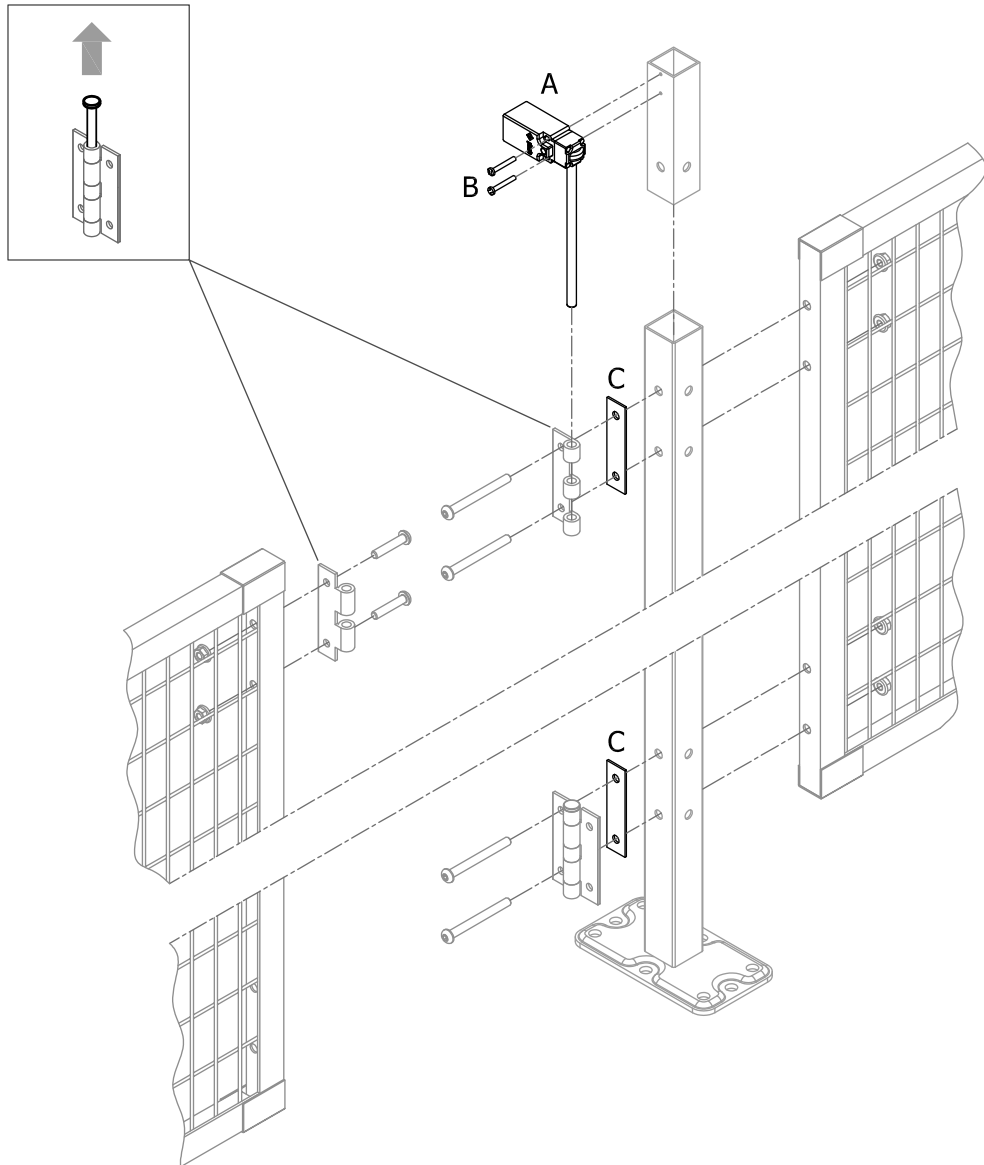
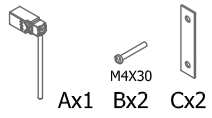

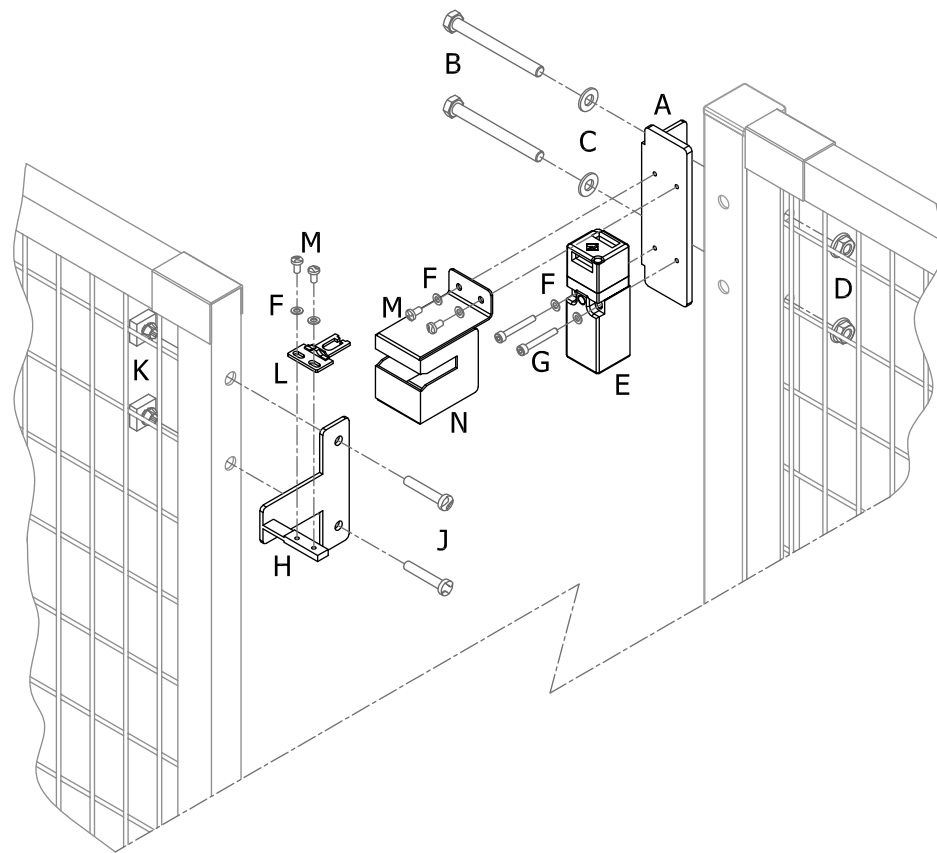
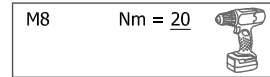
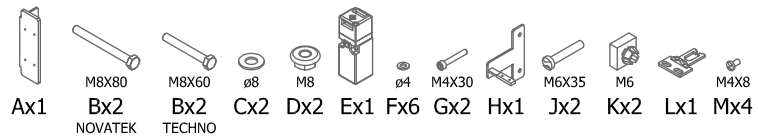
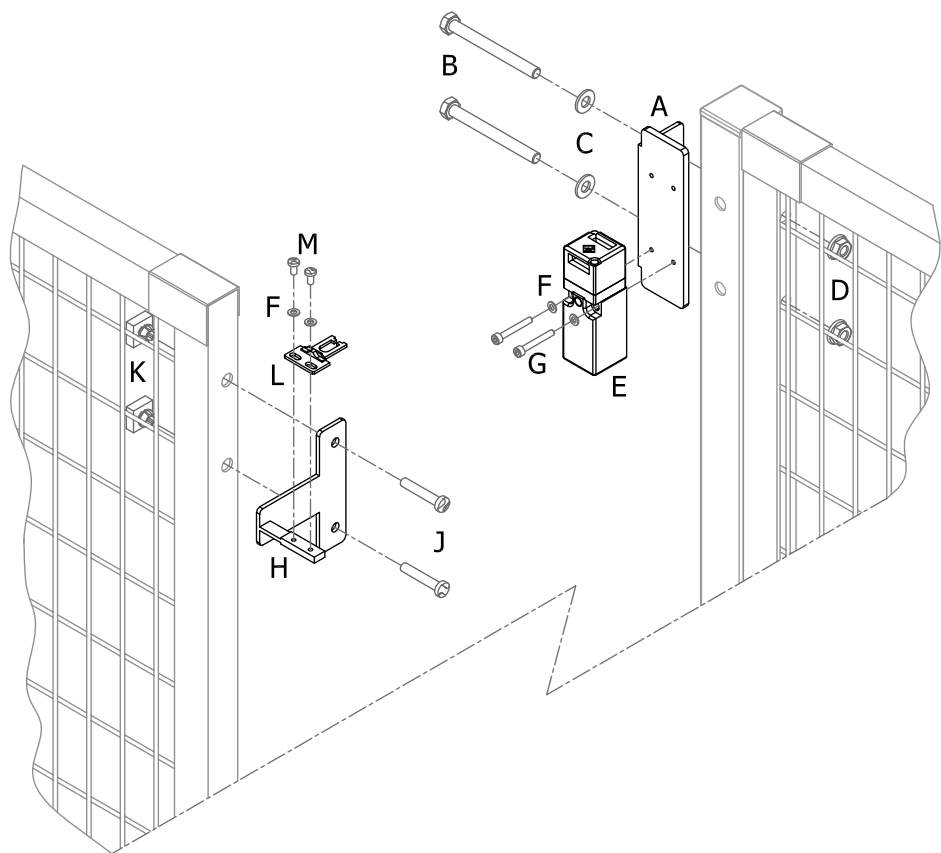
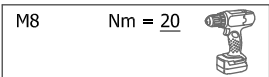
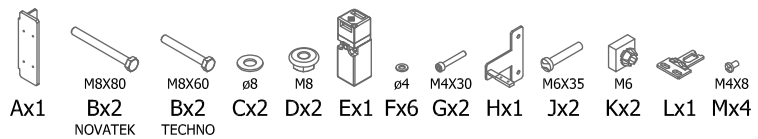

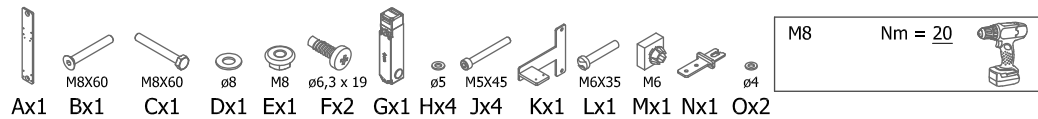

M4X10  
Px2

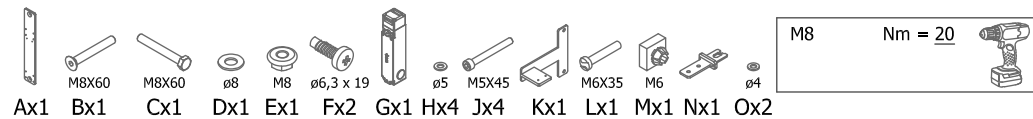
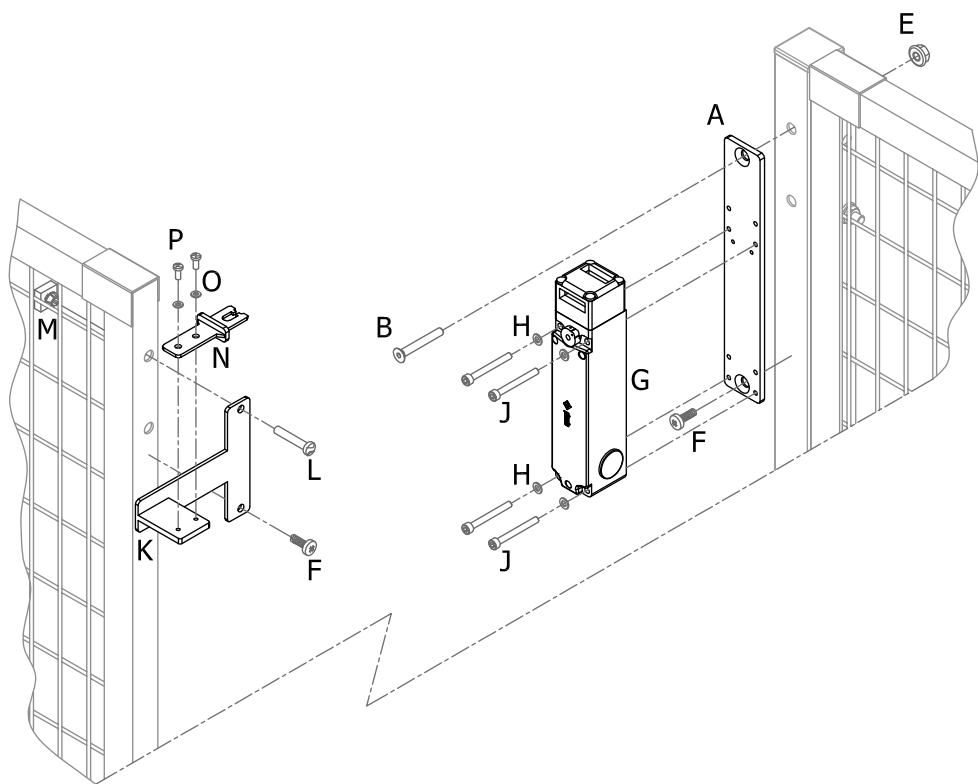

M4X10  
Px2 Qx1

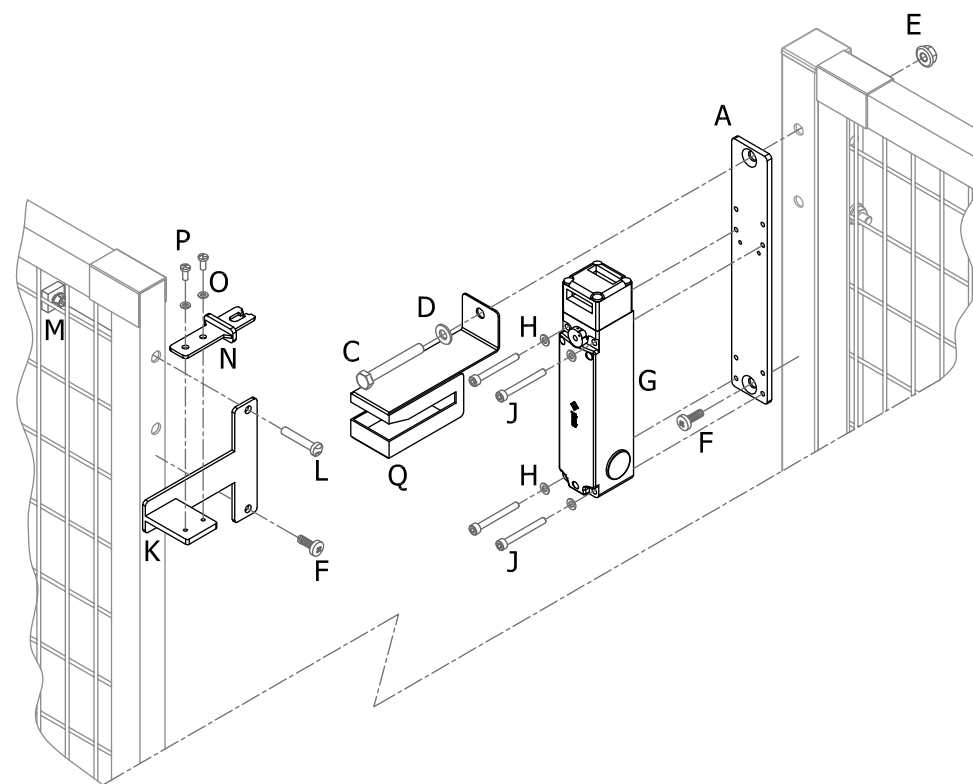

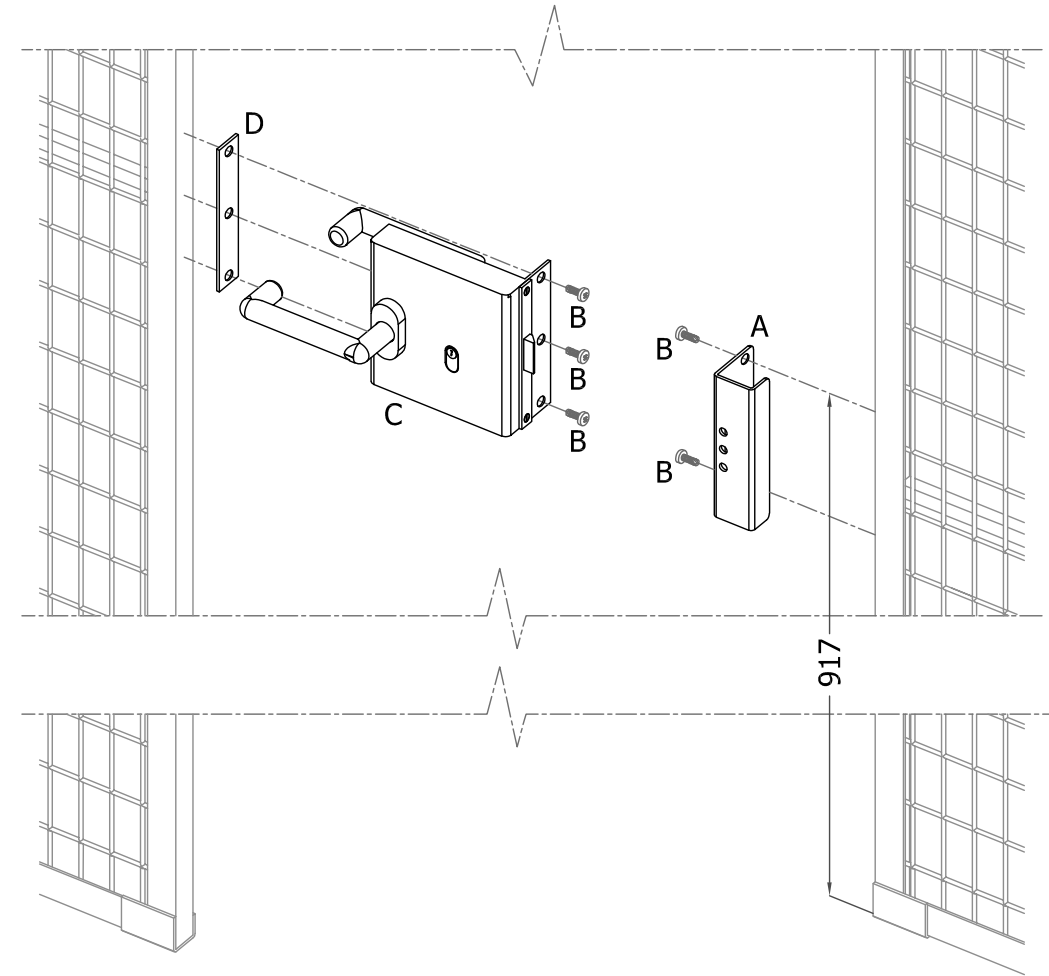
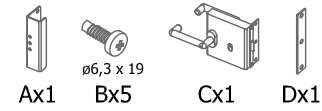
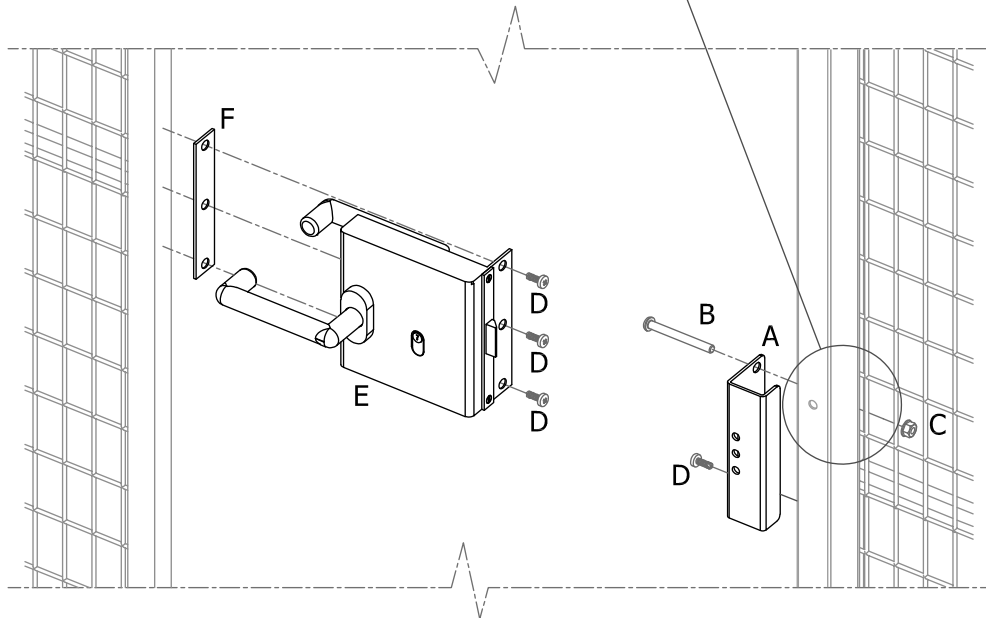
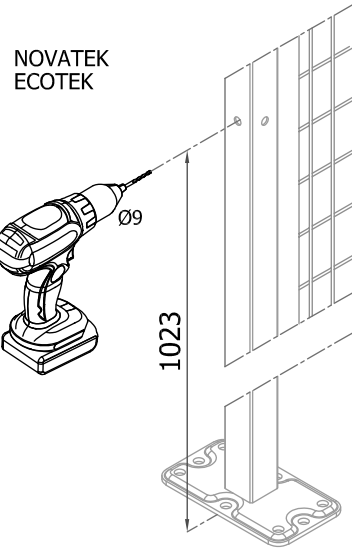
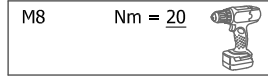
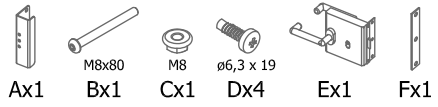

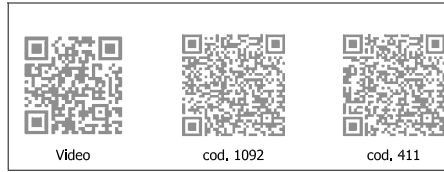
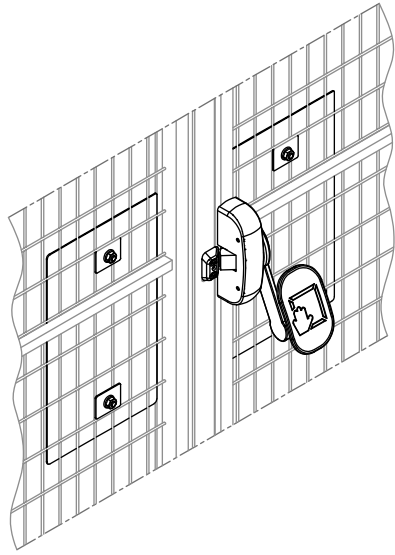



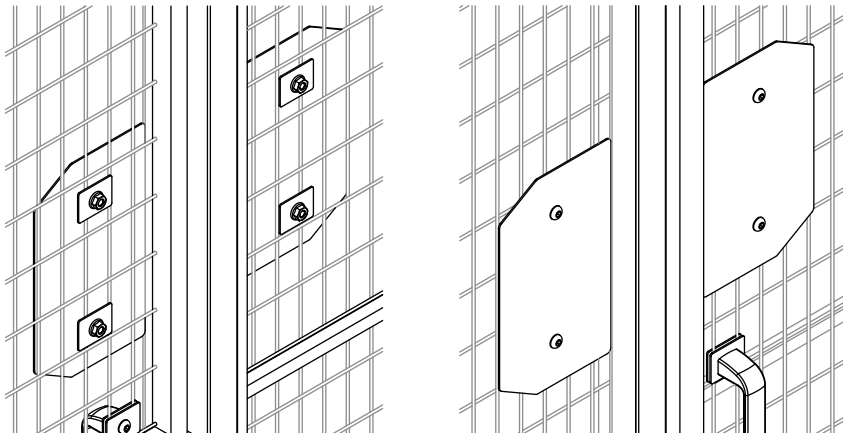
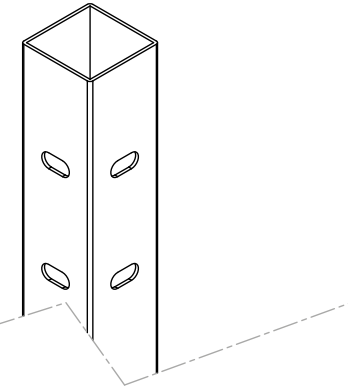
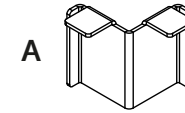
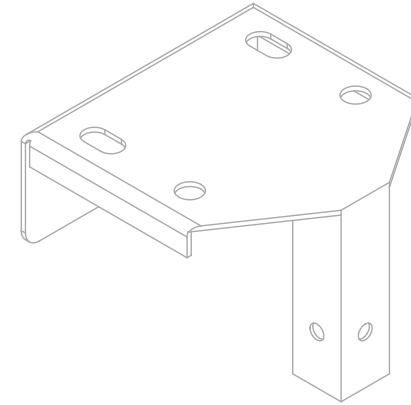

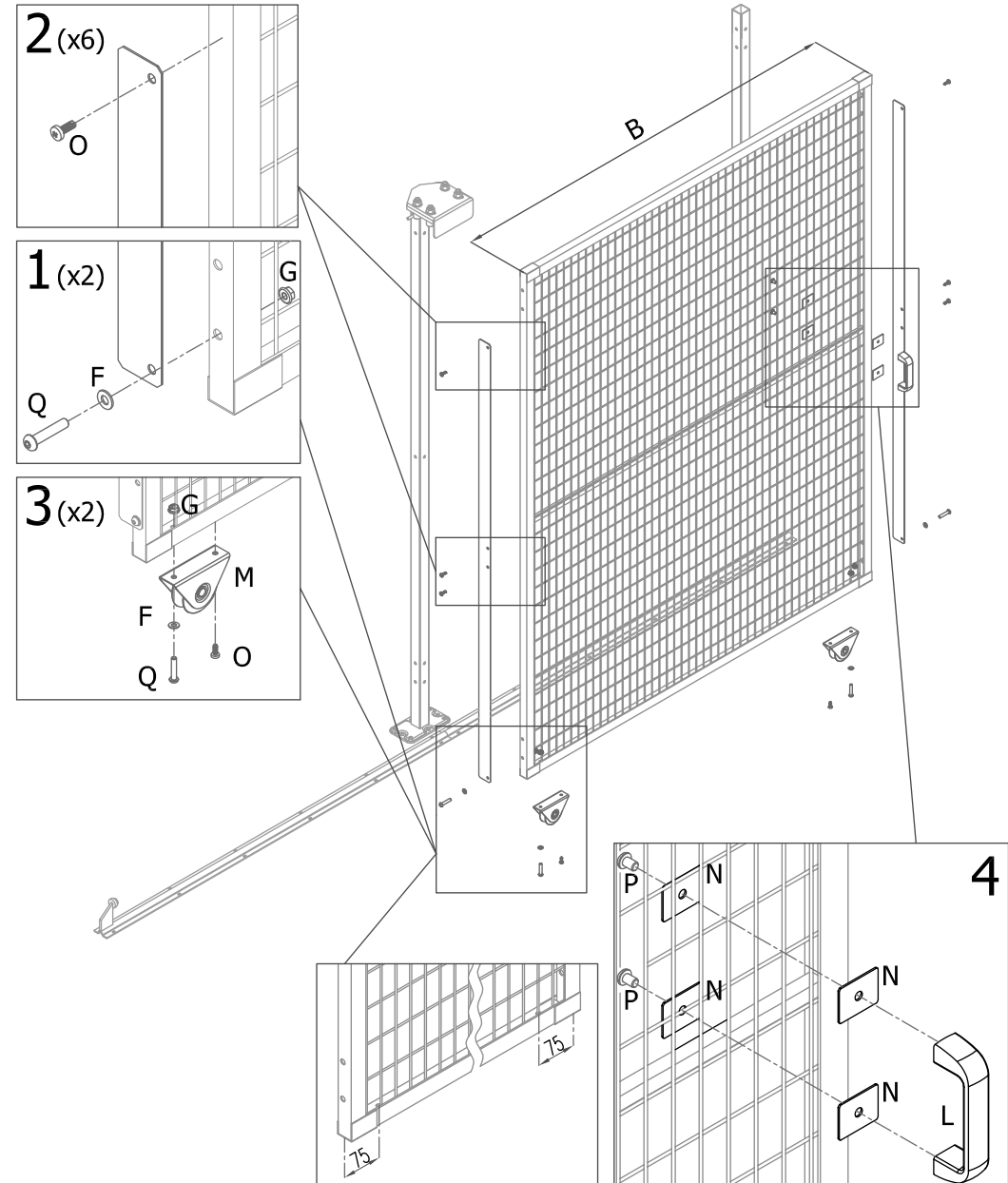
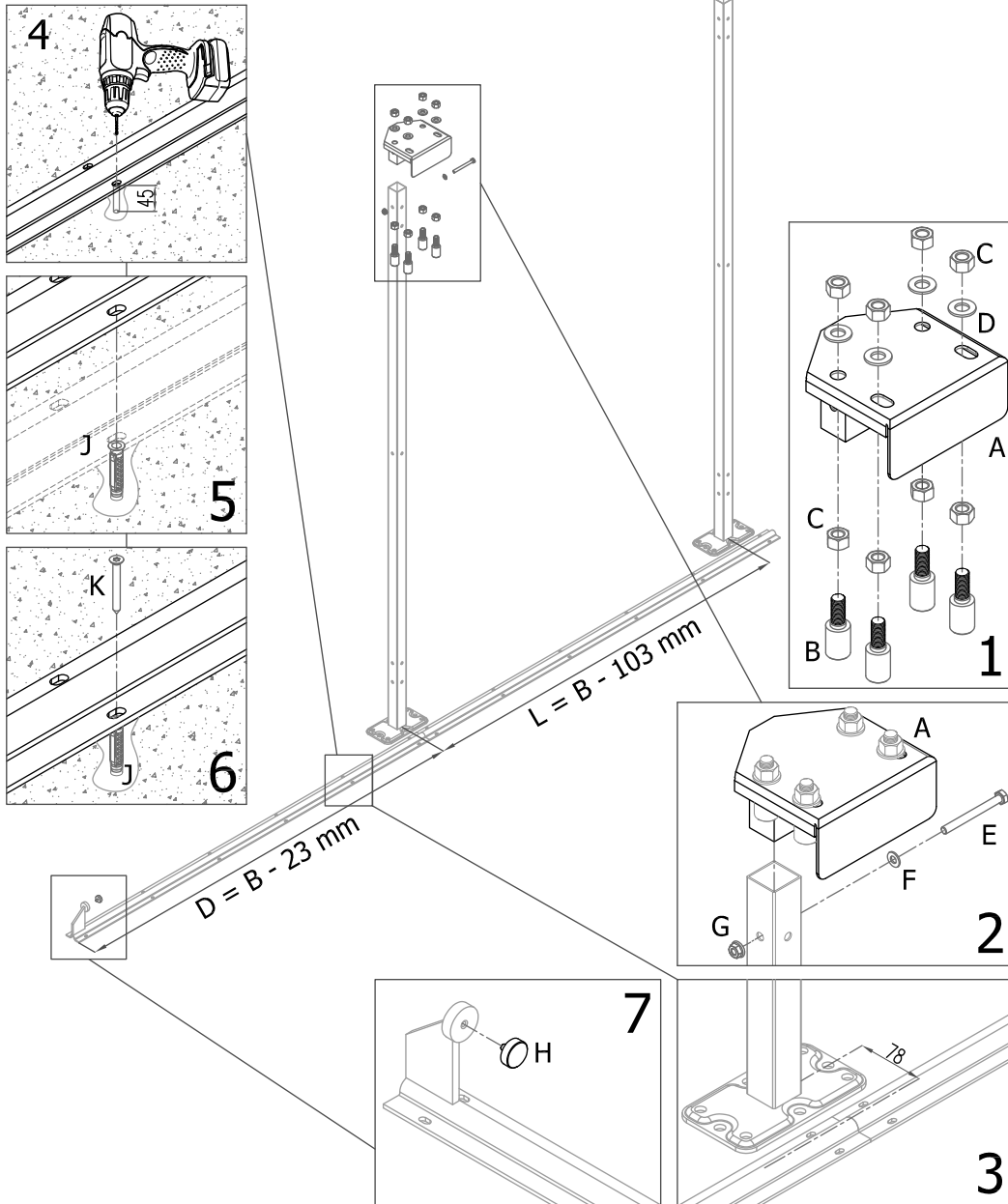
Ax1



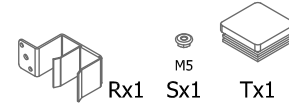
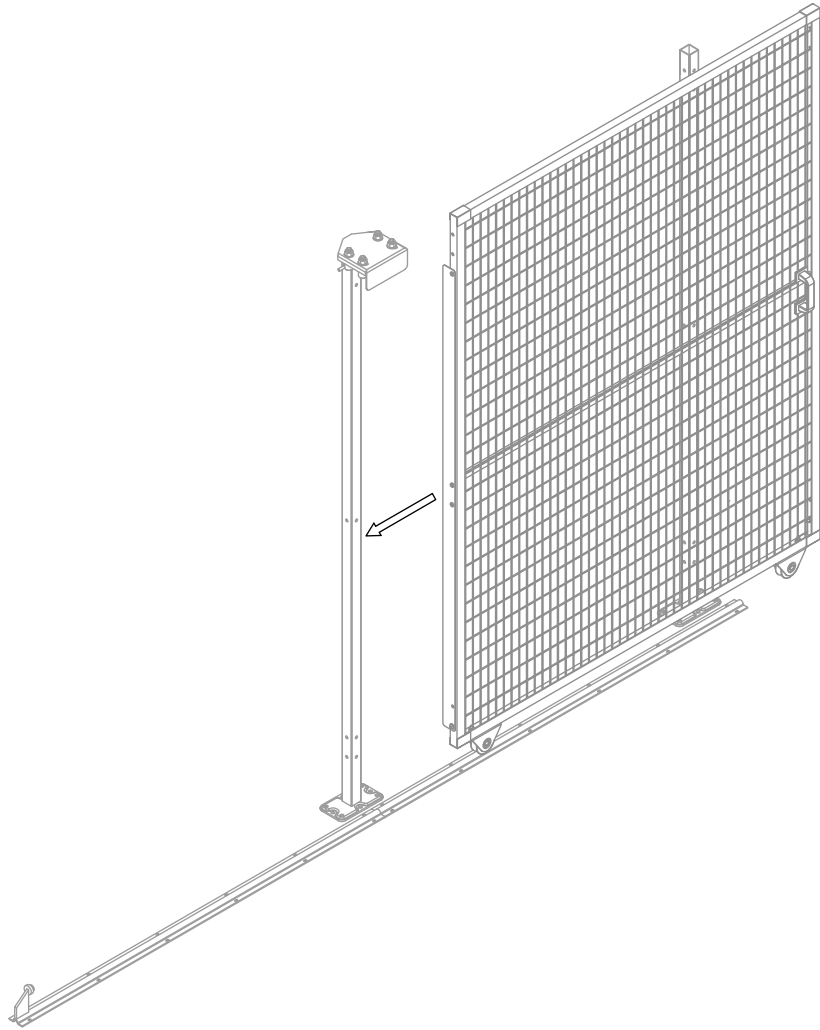

M8(E,Q)	Nm = 20	
M8(P)	Nm = 7÷8	
M5	Nm = 5	



M8(E,Q)	Nm = 20	
M8(P)	Nm = 7÷8	
M5	Nm = 5	

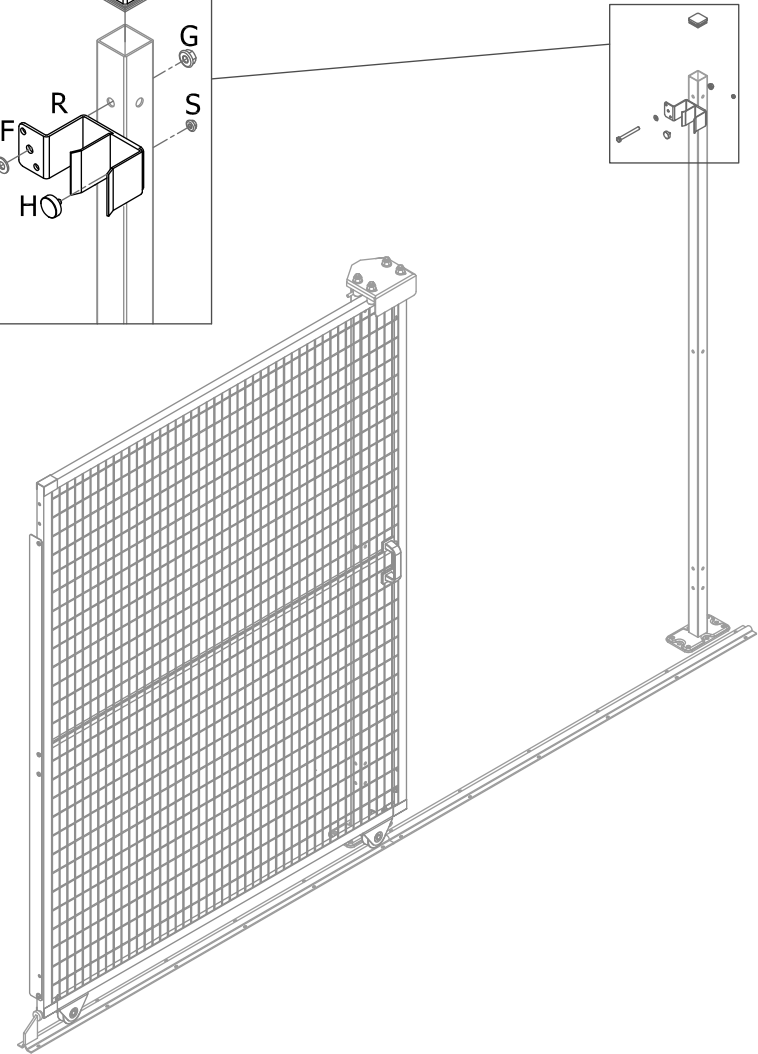
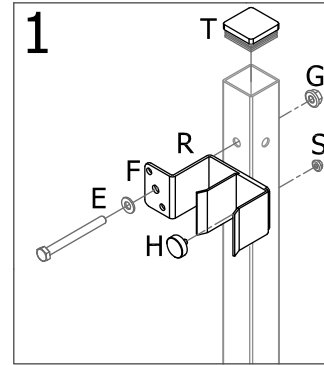



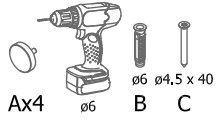

M8(H,Q)	Nm = 20	
M8(P)	Nm = 7±8	
M5	Nm = 5	

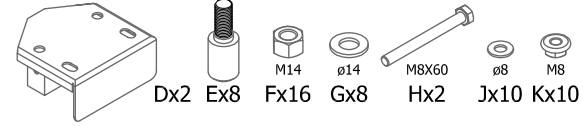
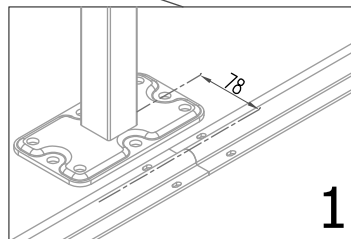
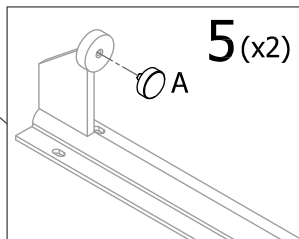
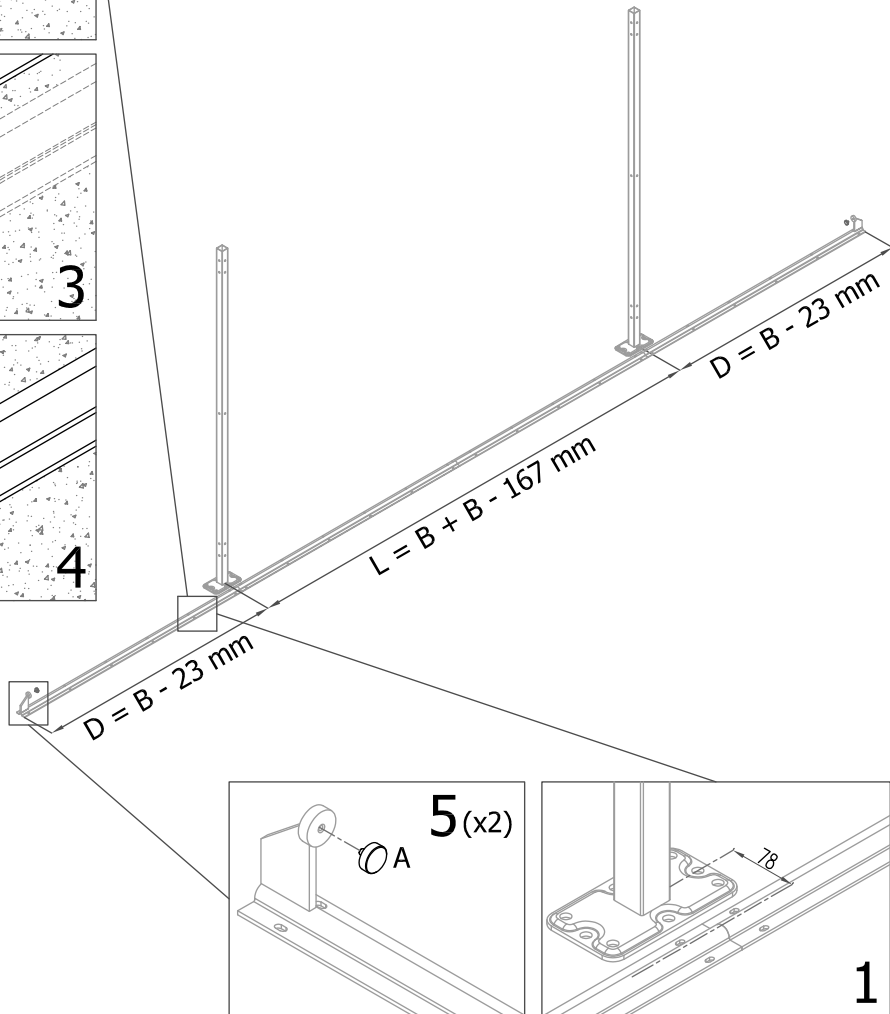
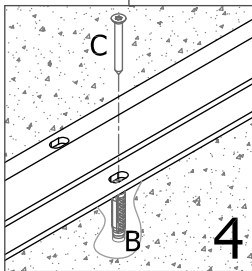
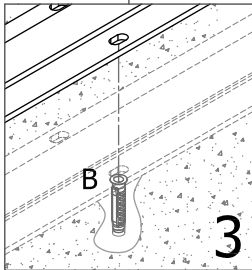
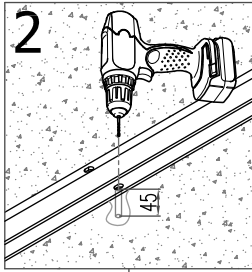

M8(H,Q)	Nm = 20	
M8(P)	Nm = 7±8	
M5	Nm = 5	

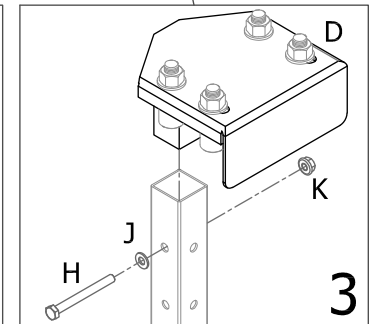
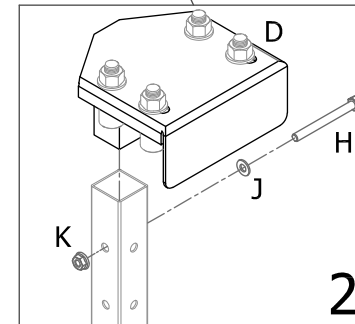
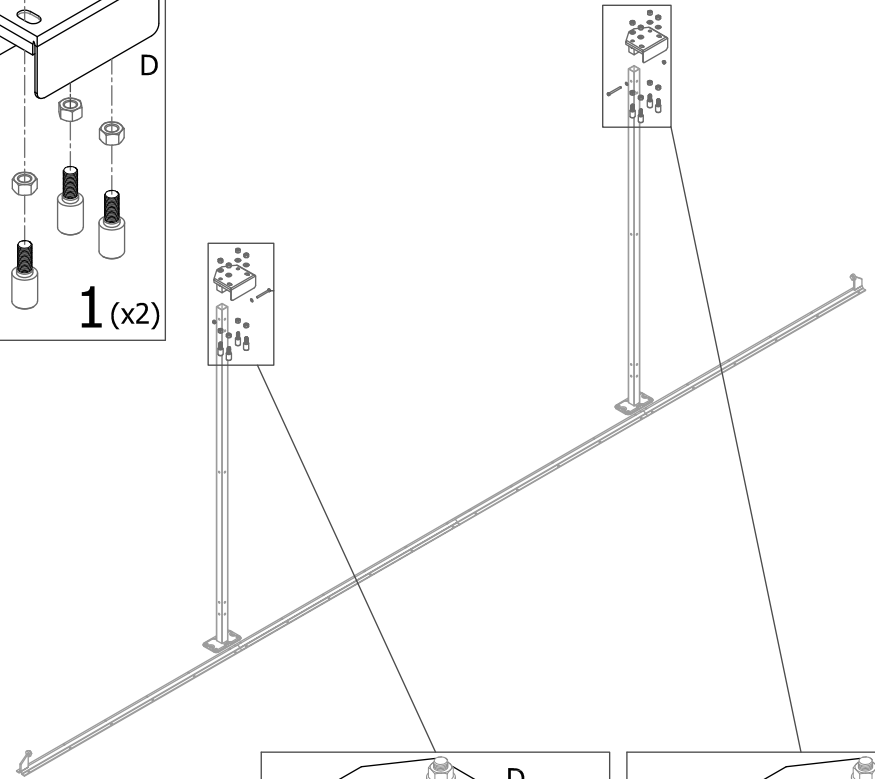
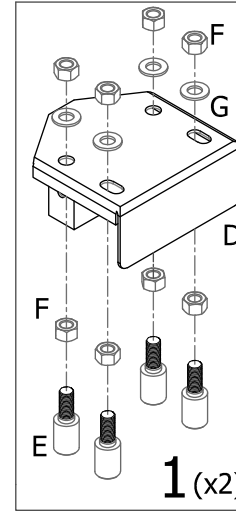

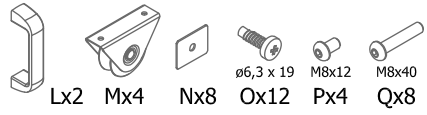

M8(H,Q)	Nm = 20	
M8(P)	Nm = 7÷8	
M5	Nm = 5	

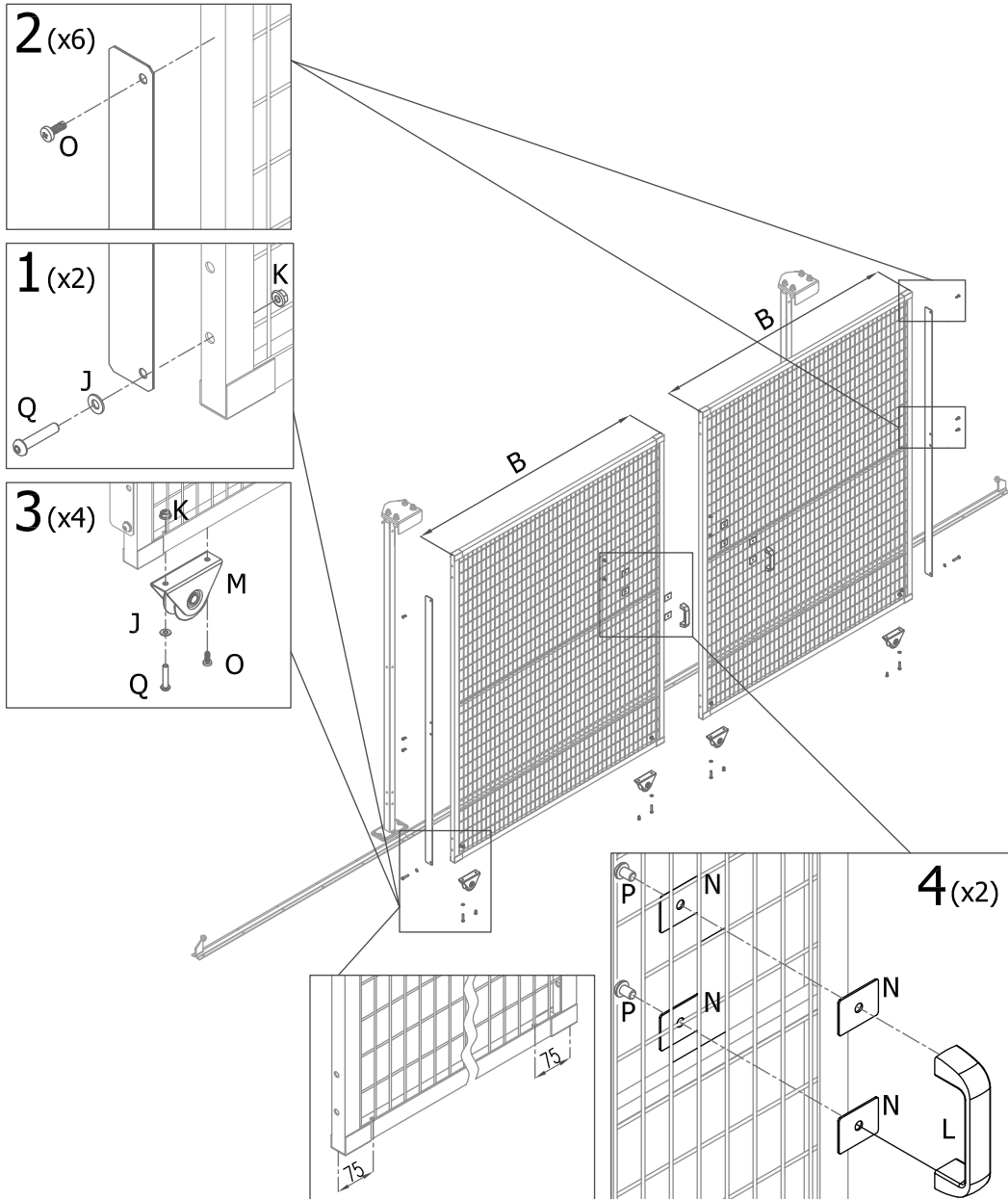

M8(H,Q)	Nm = 20	
M8(P)	Nm = 7÷8	
M5	Nm = 5	

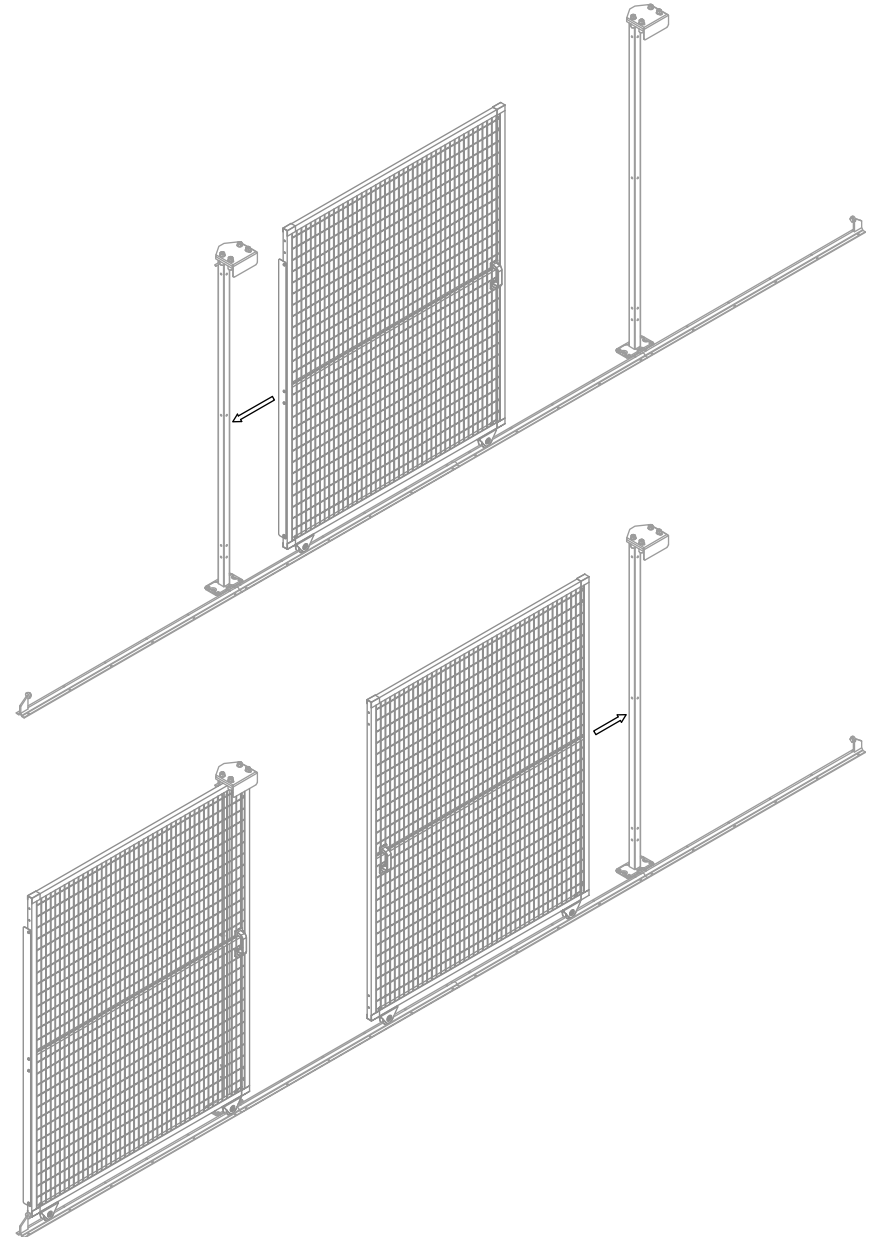

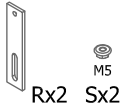

M8(H,Q)	Nm = 20	
M8(P)	Nm = 7±8	
M5	Nm = 5	

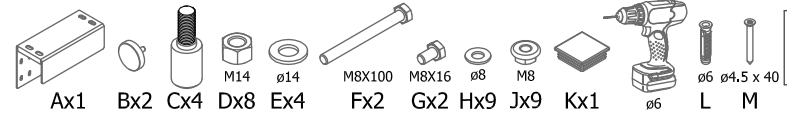
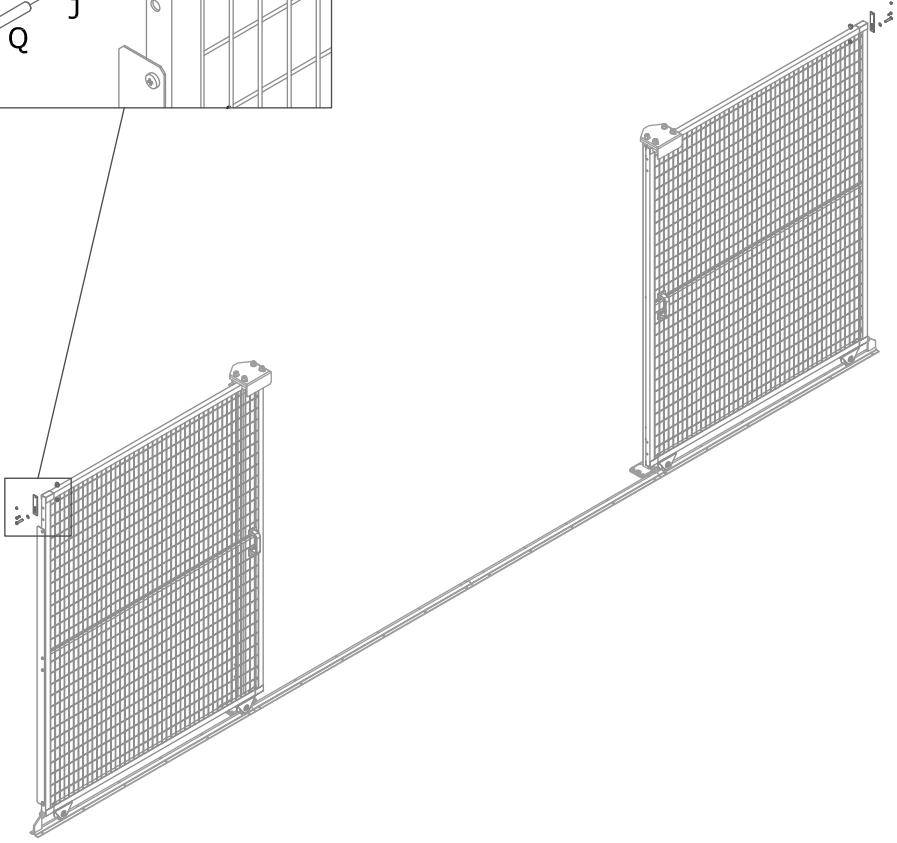
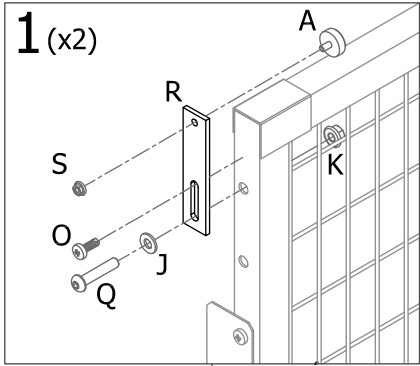

M8(F,S,U)	Nm = 20	
M8(G,R)	Nm = 7±8	
M5	Nm = 5	

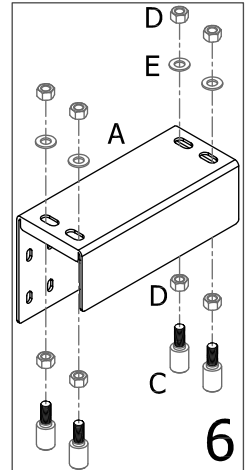
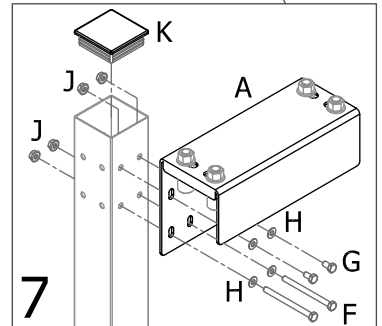
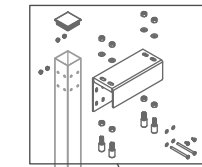
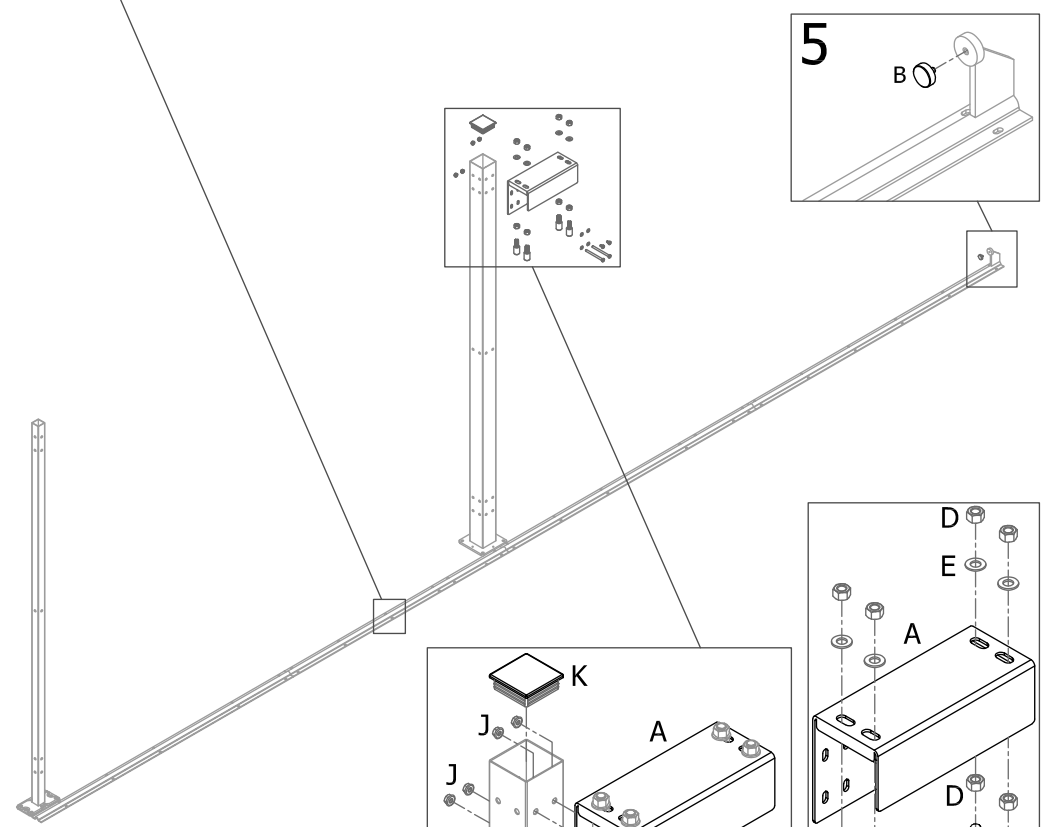
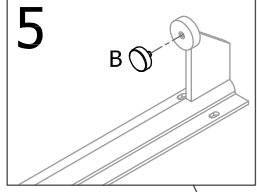
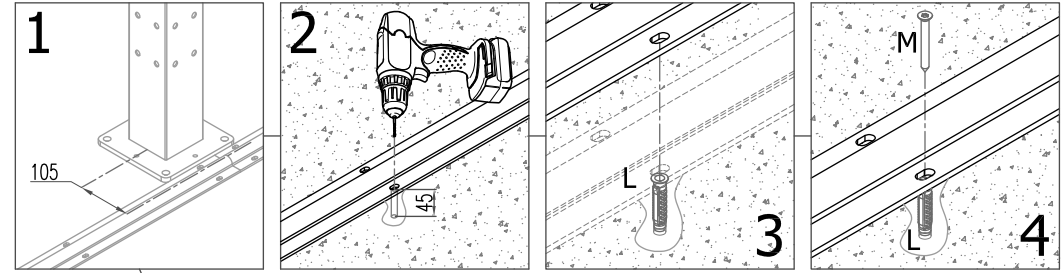

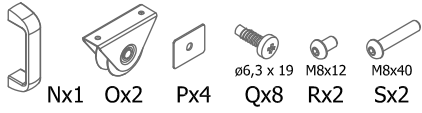

M8(F,S,U)	Nm = 20	
M8(G,R)	Nm = 7±8	
M5	Nm = 5	

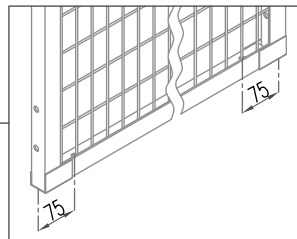
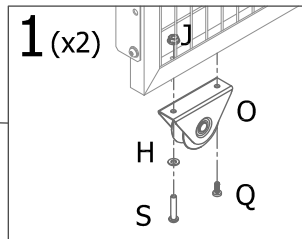
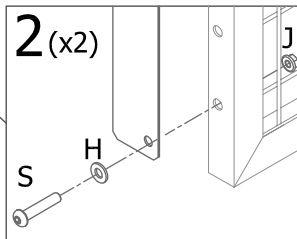
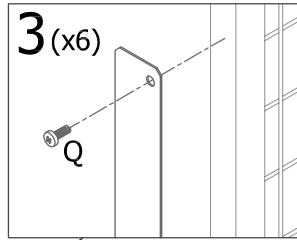
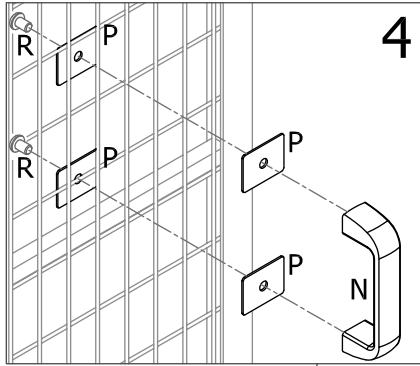

M8(F,S,U)	Nm = 20	
M8(G,R)	Nm = 7±8	
M5	Nm = 5	

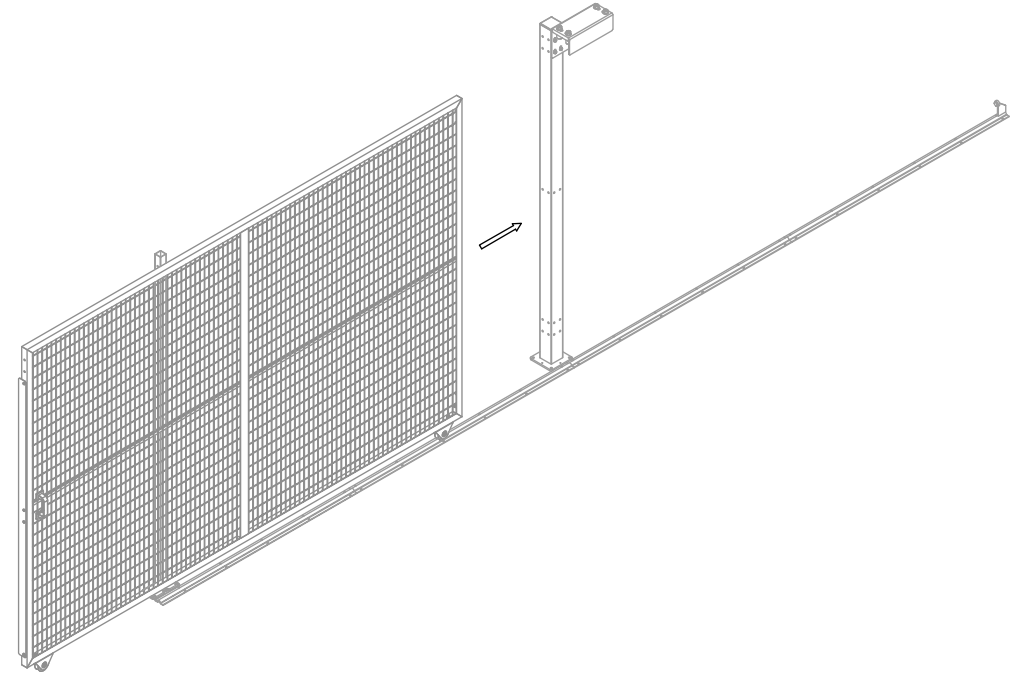

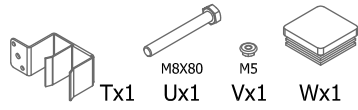

M8(F,S,U)	Nm = 20	
M8(G,R)	Nm = 7±8	
M5	Nm = 5	

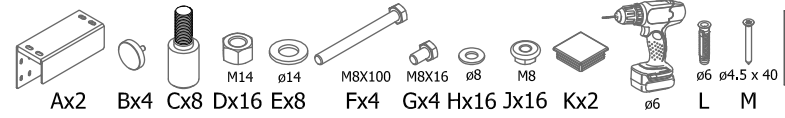
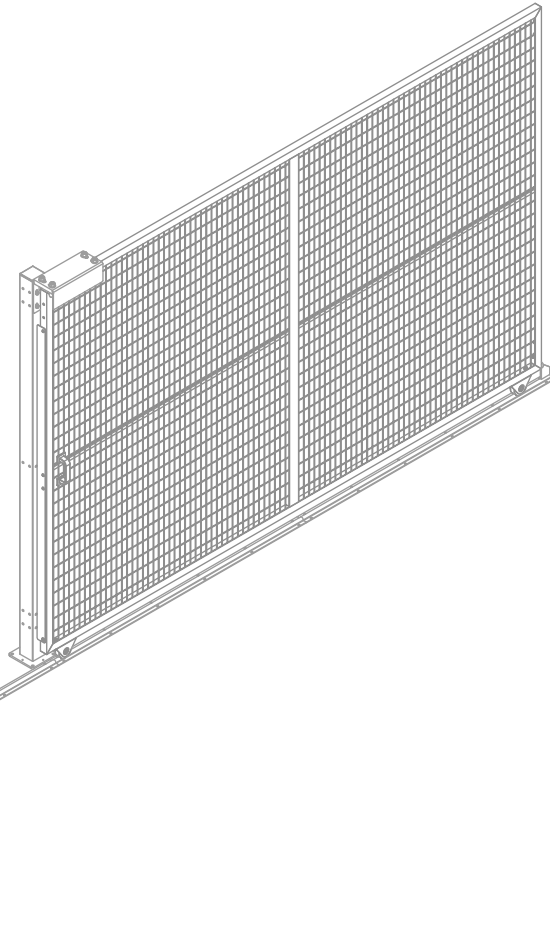
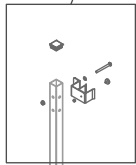
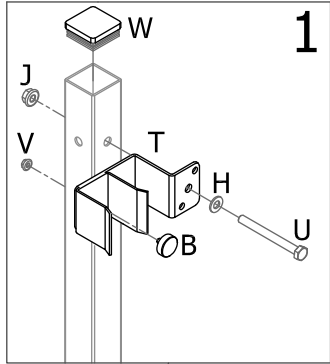

M8(F,S,U)	Nm = 20	
M8(G,R)	Nm = 7±8	
M5	Nm = 5	

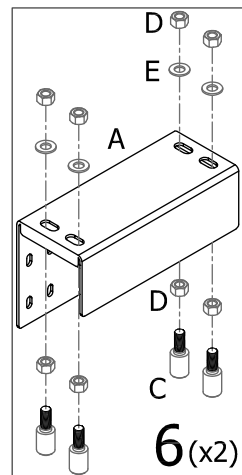
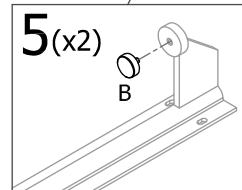
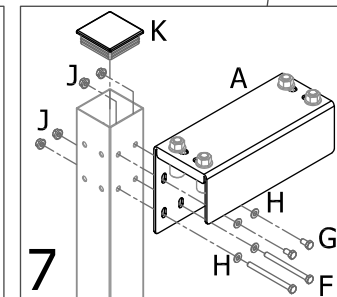
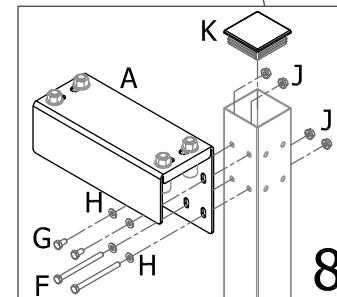
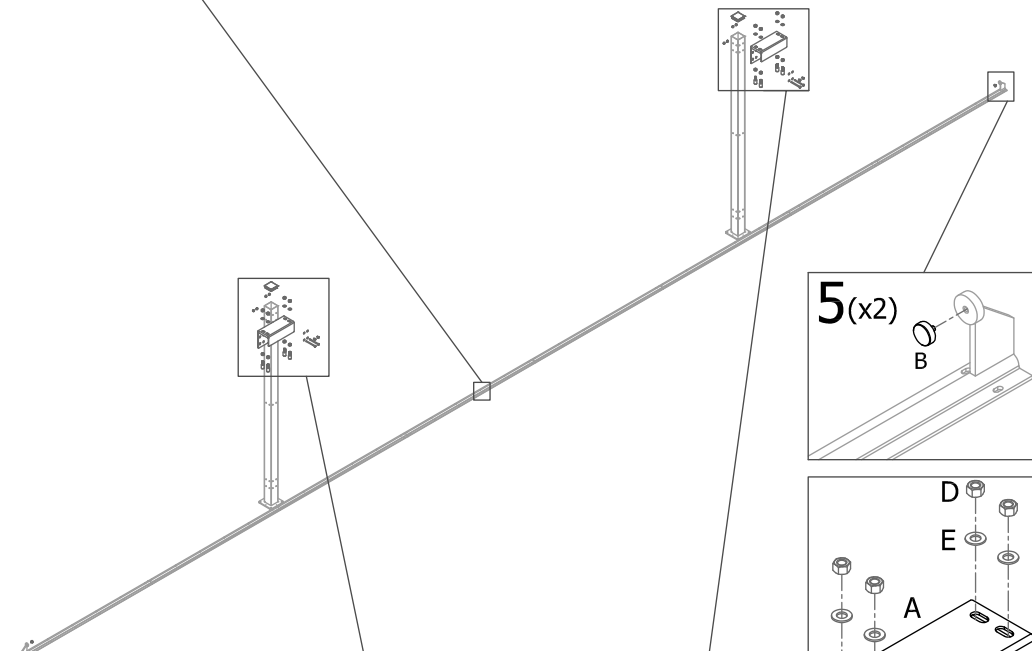
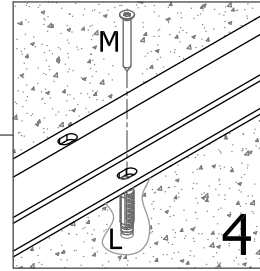
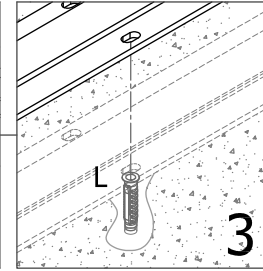
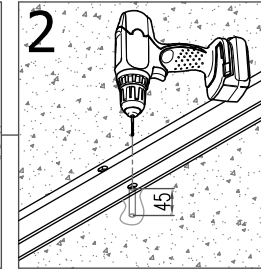
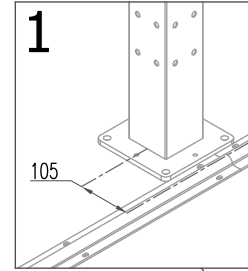

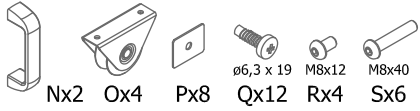

M8(F,S,U)	Nm = 20	
M8(G,R)	Nm = 7÷8	
M5	Nm = 5	

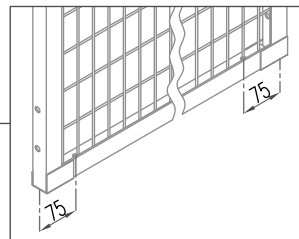
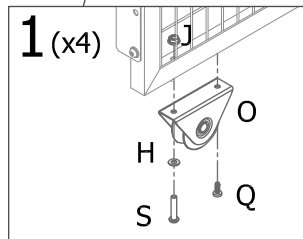
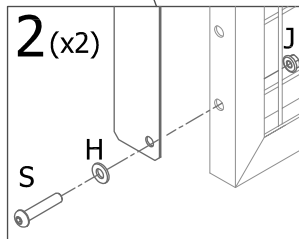
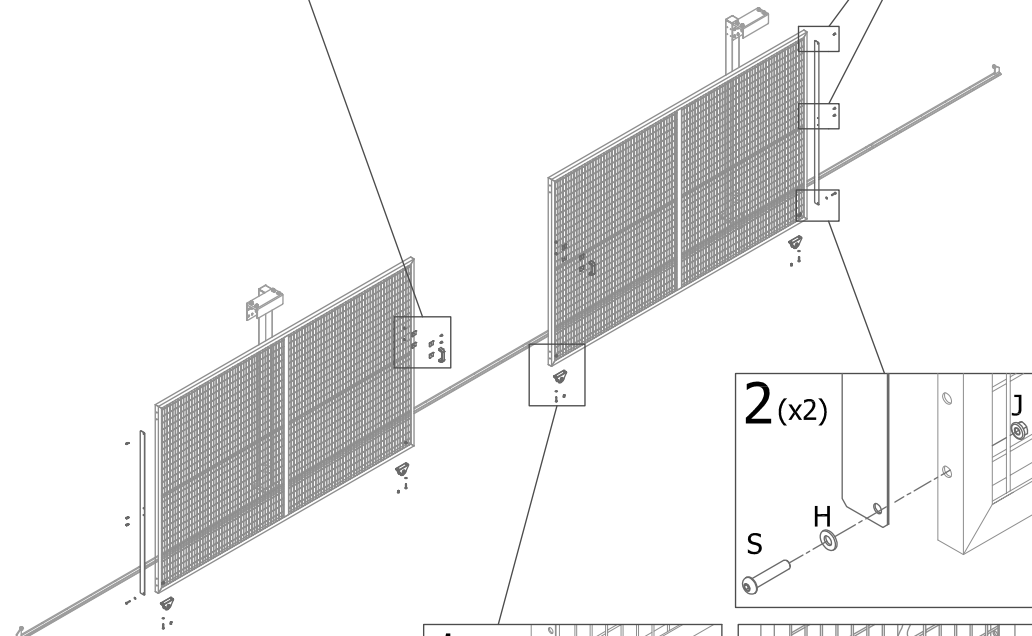
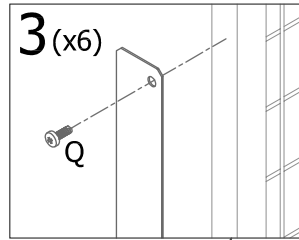
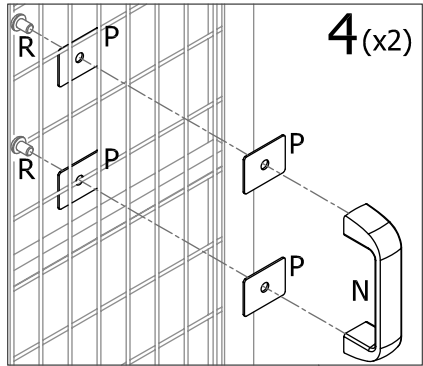

M8(F,S,U)	Nm = 20	
M8(G,R)	Nm = 7÷8	
M5	Nm = 5	

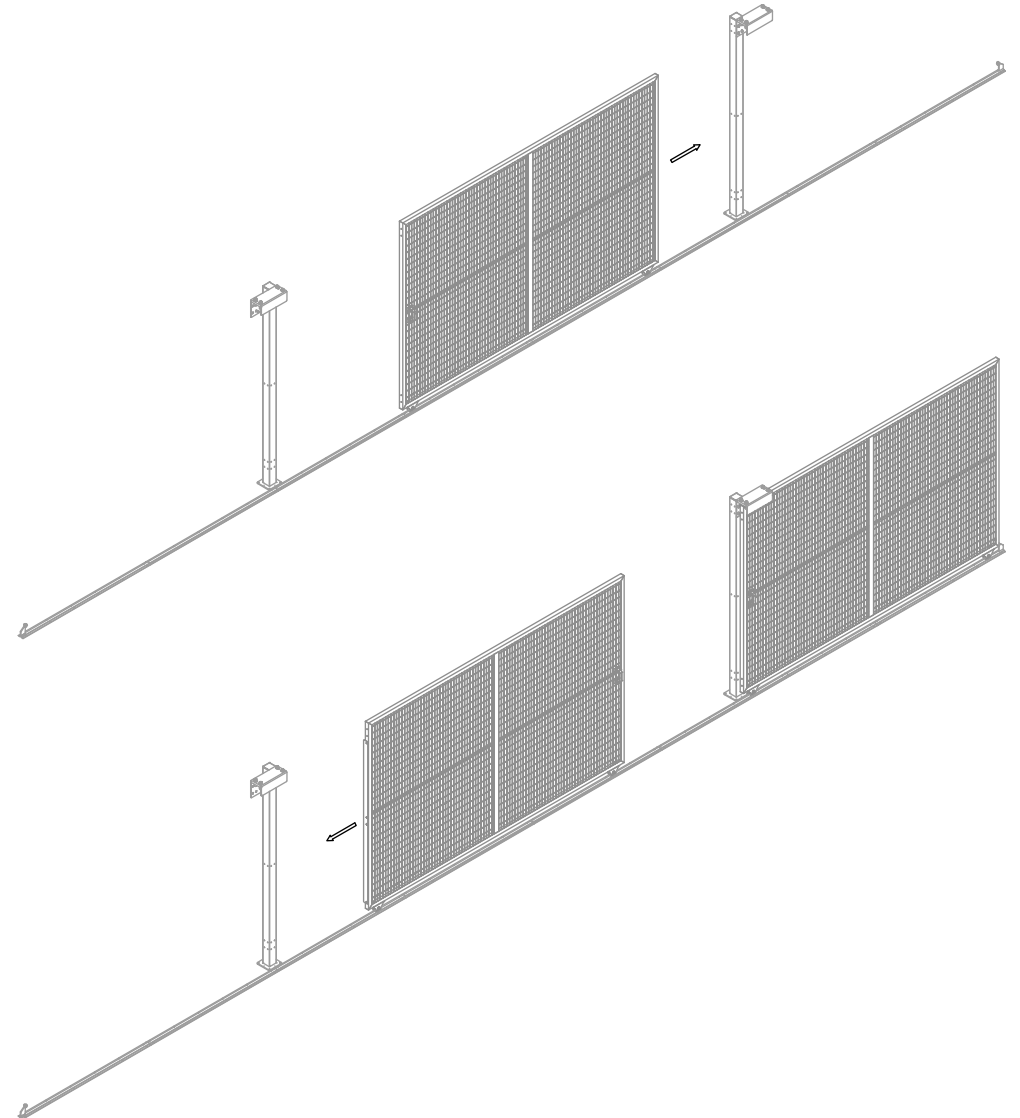

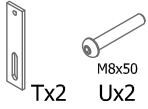

M8(F,S,U)	Nm = 20	
M8(G,R)	Nm = 7÷8	
M5	Nm = 5	

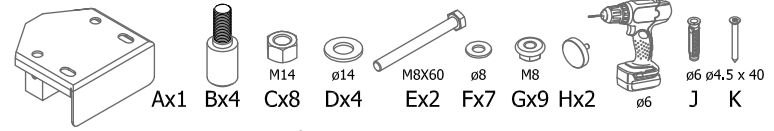
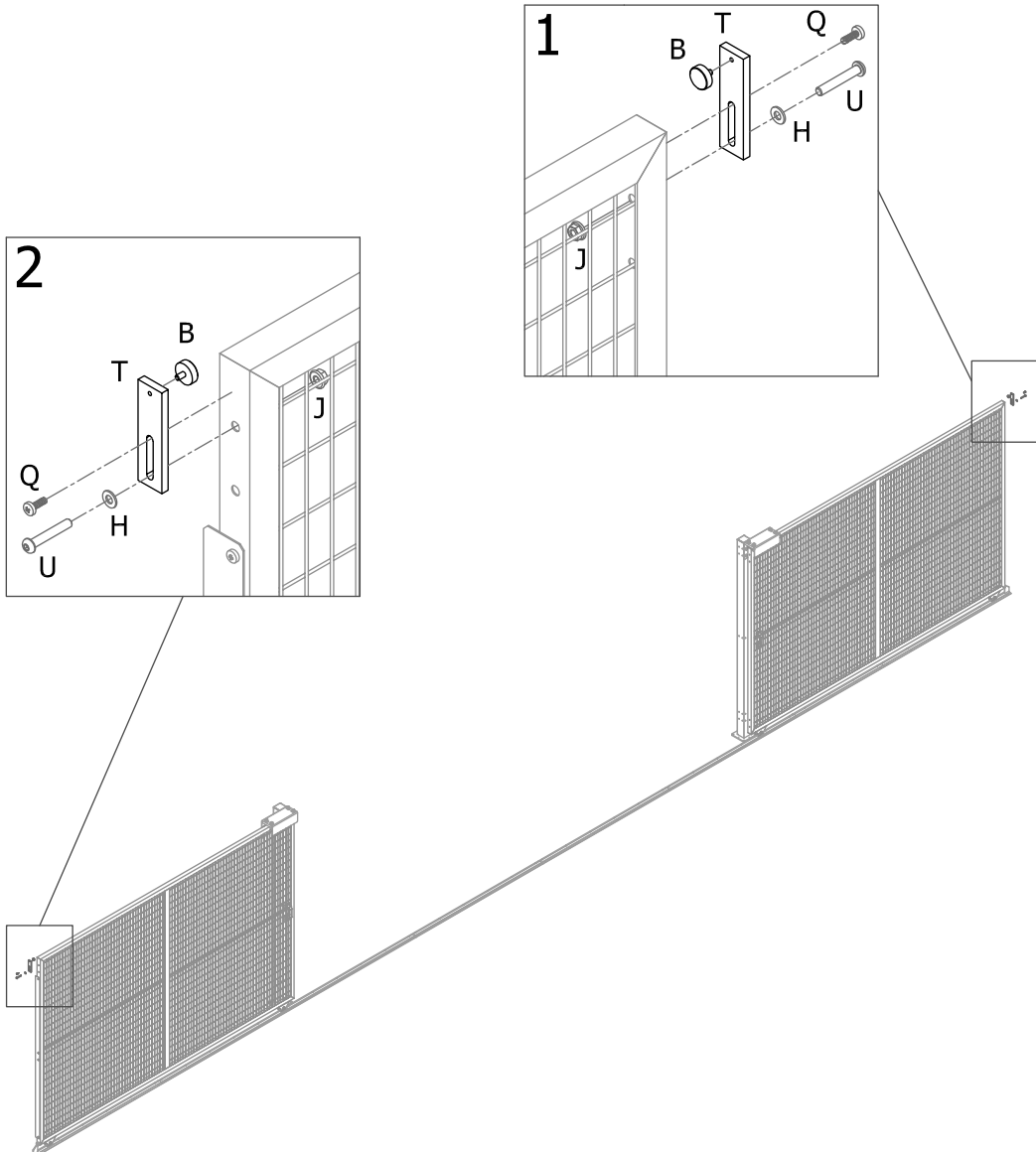

M8(E,Q,R,T)	Nm = 20	
M8(S,V)	Nm = 7÷8	
M5	Nm = 5	

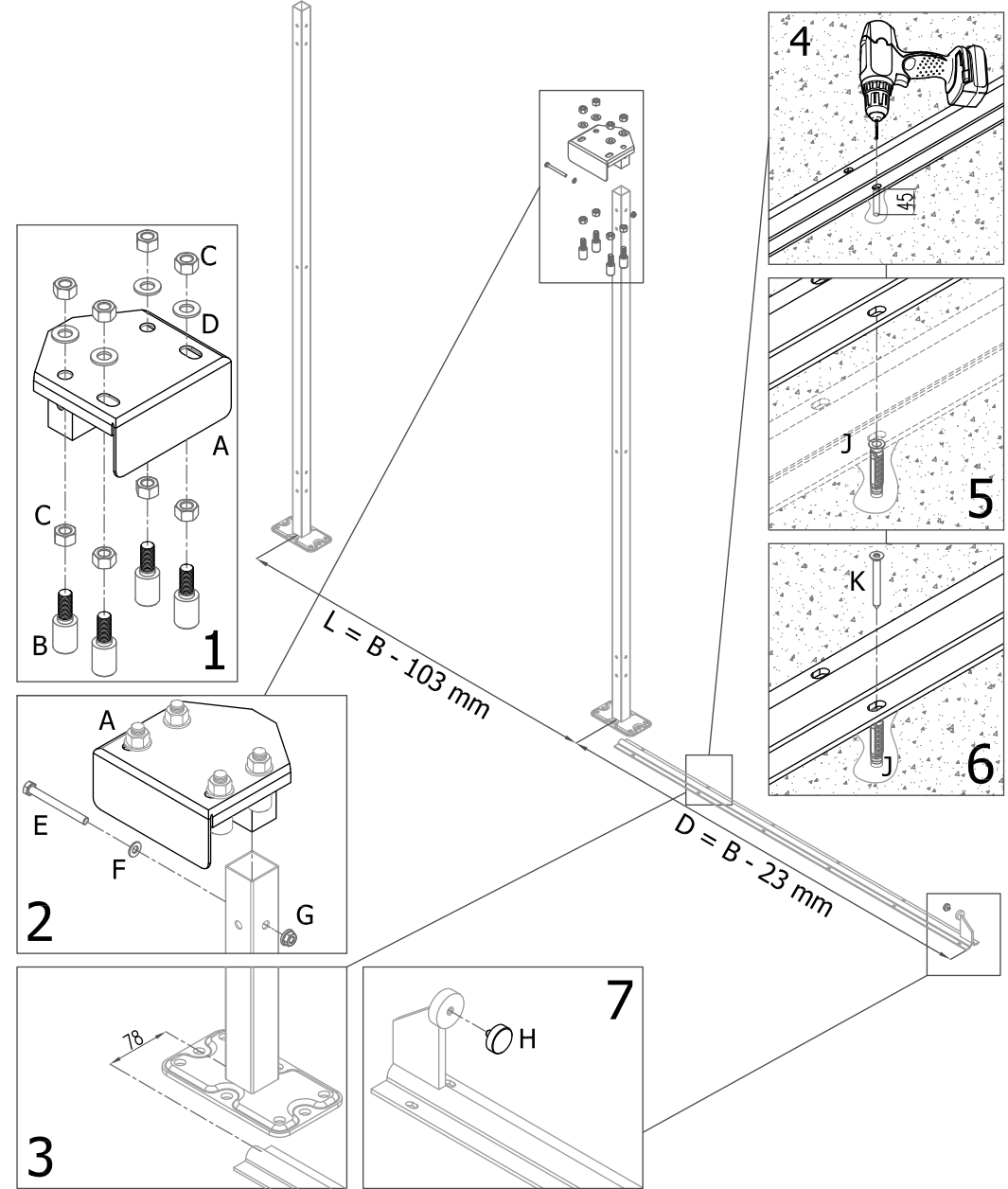



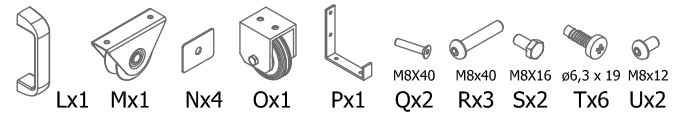
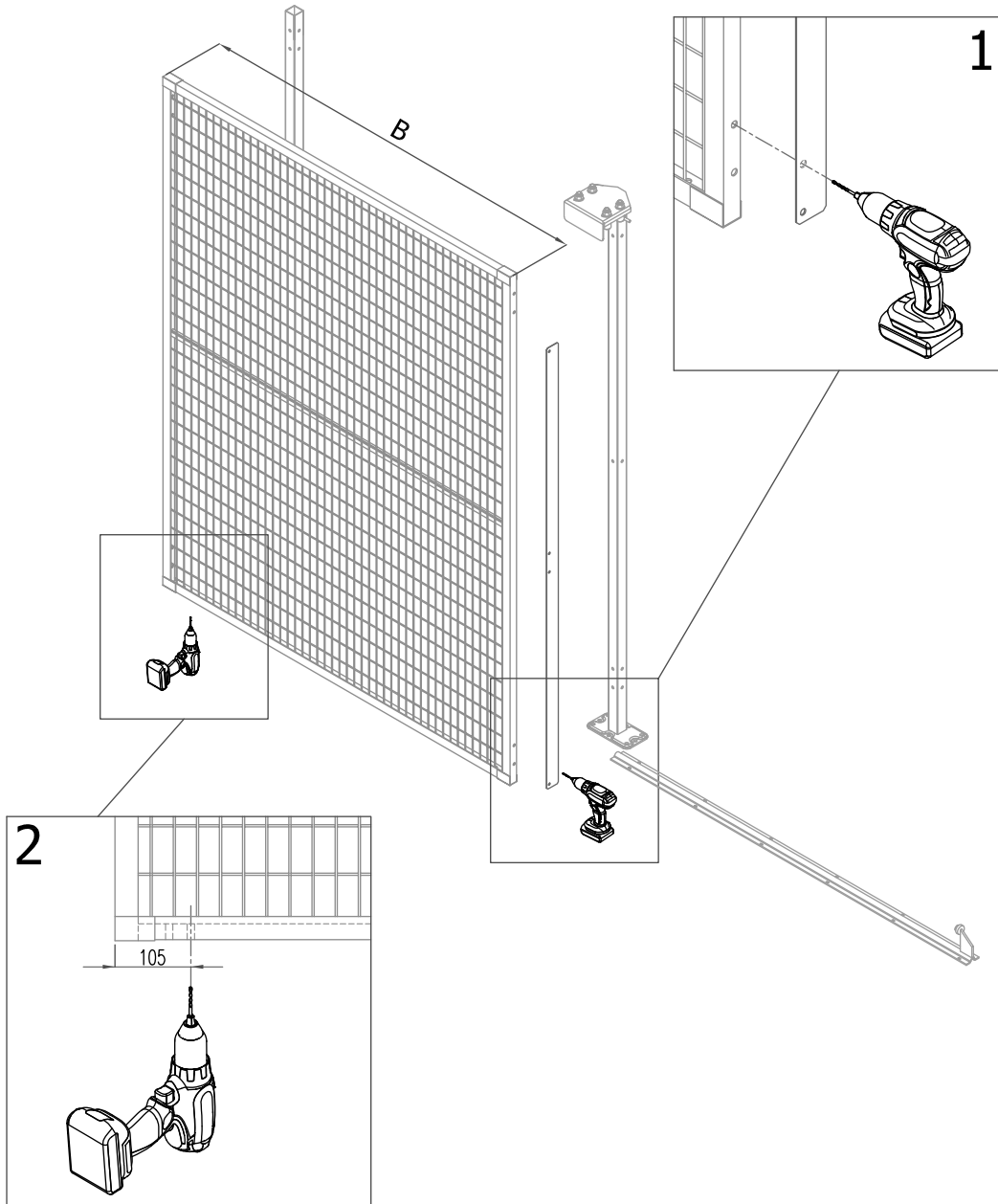

M8(E,Q,R,T)	Nm = 20	
M8(S,V)	Nm = 7÷8	
M5	Nm = 5	



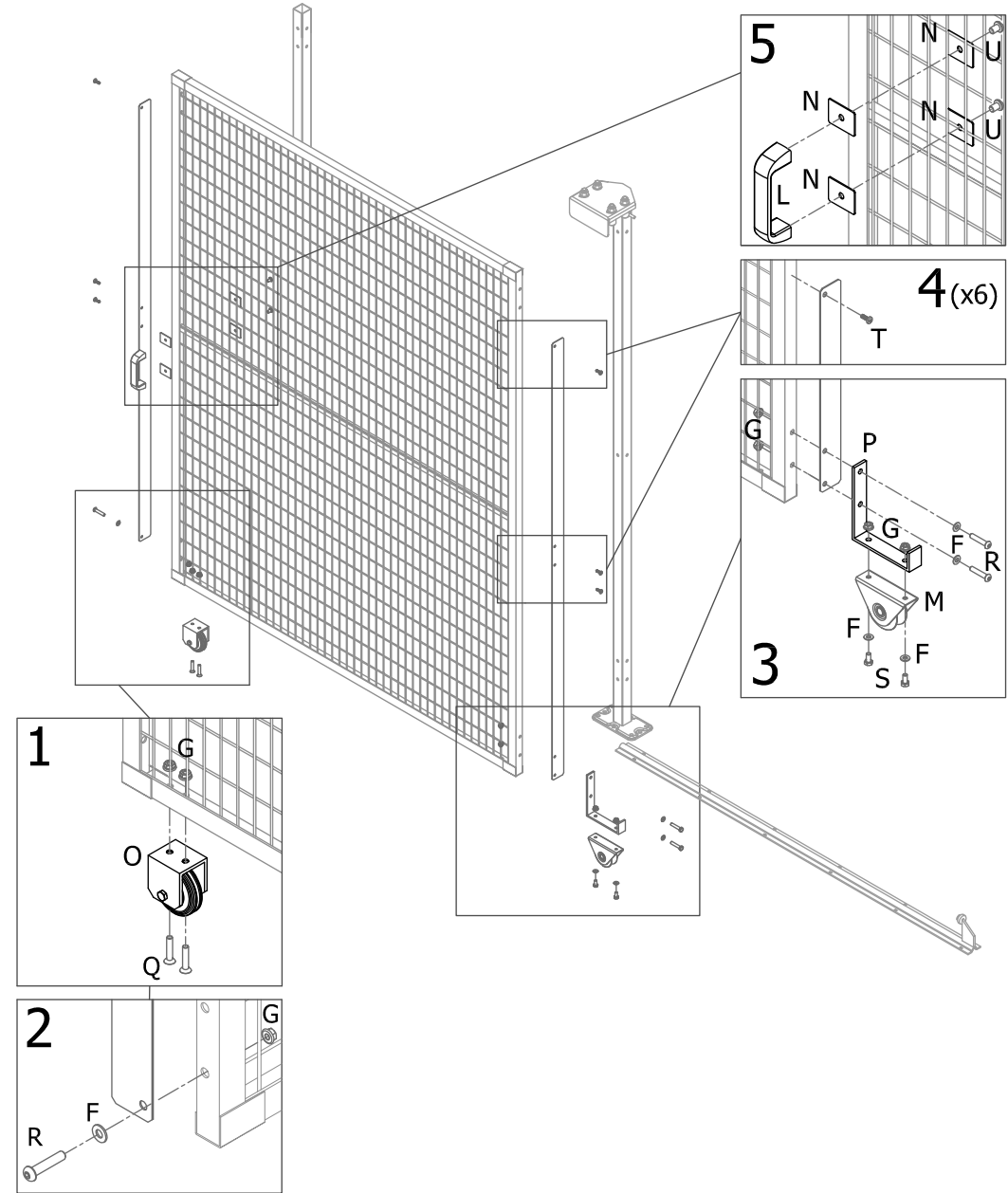



M8(E,Q,R,T)	Nm = 20	
M8(S,V)	Nm = 7÷8	
M5	Nm = 5	



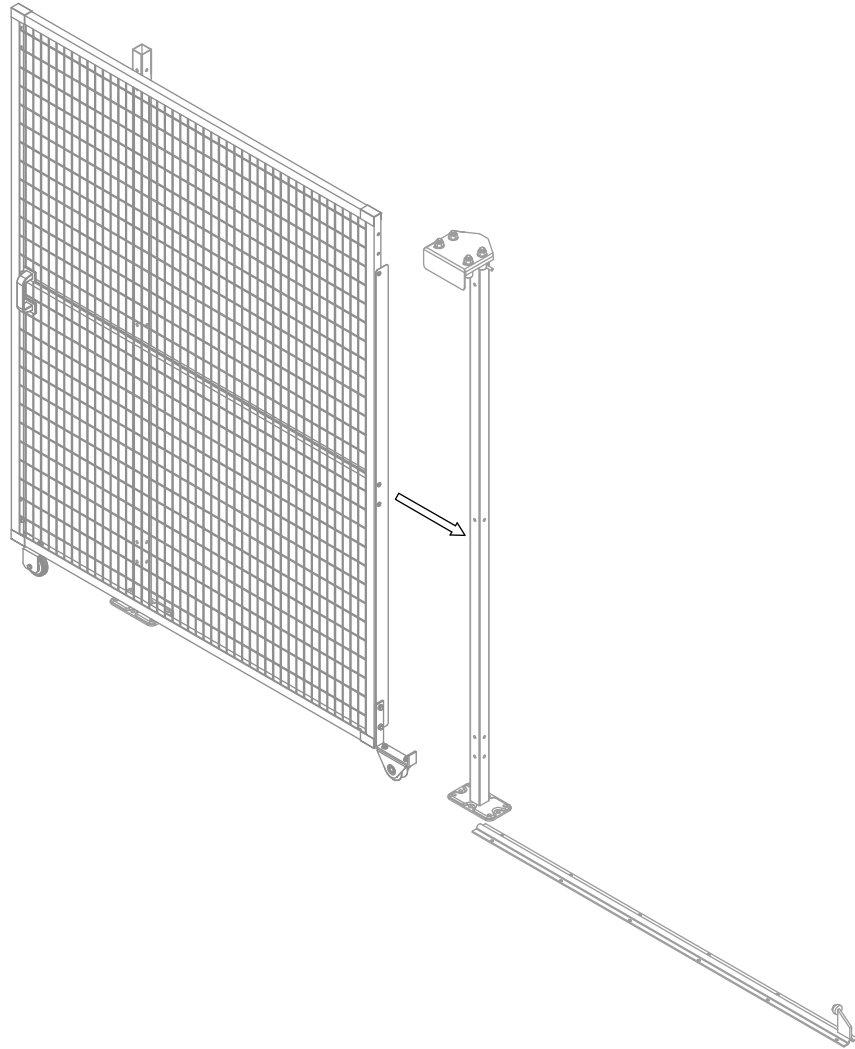

M8(E,Q,R,T)	Nm = 20	
M8(S,V)	Nm = 7÷8	
M5	Nm = 5	



 Vx1  M5  Yx1

M8(E,Q,R,T)	Nm = 20	
M8(S,V)	Nm = 7÷8	
M5	Nm = 5	

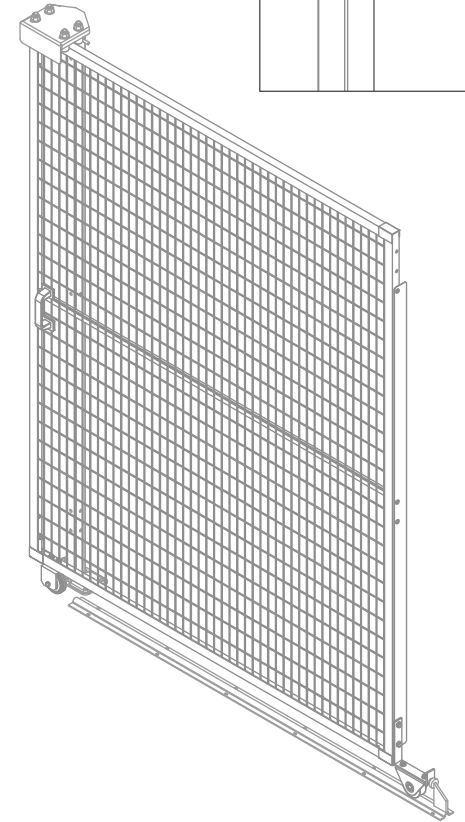
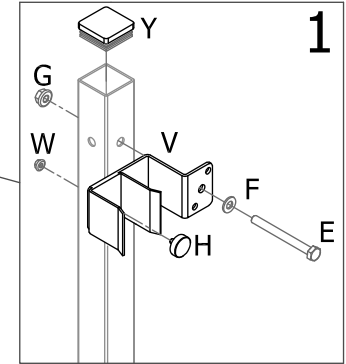
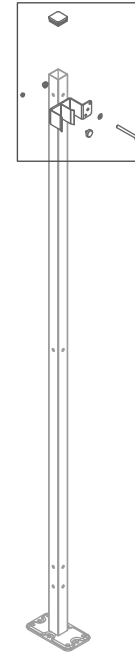

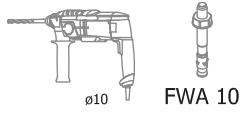

M10	M8(G,P)	Nm = 7÷8
M8(F,Q,Y,Z)		Nm = 20
M6		Nm = 10
M5		Nm = 5

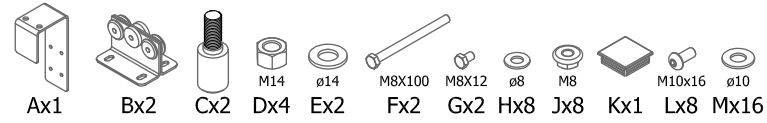
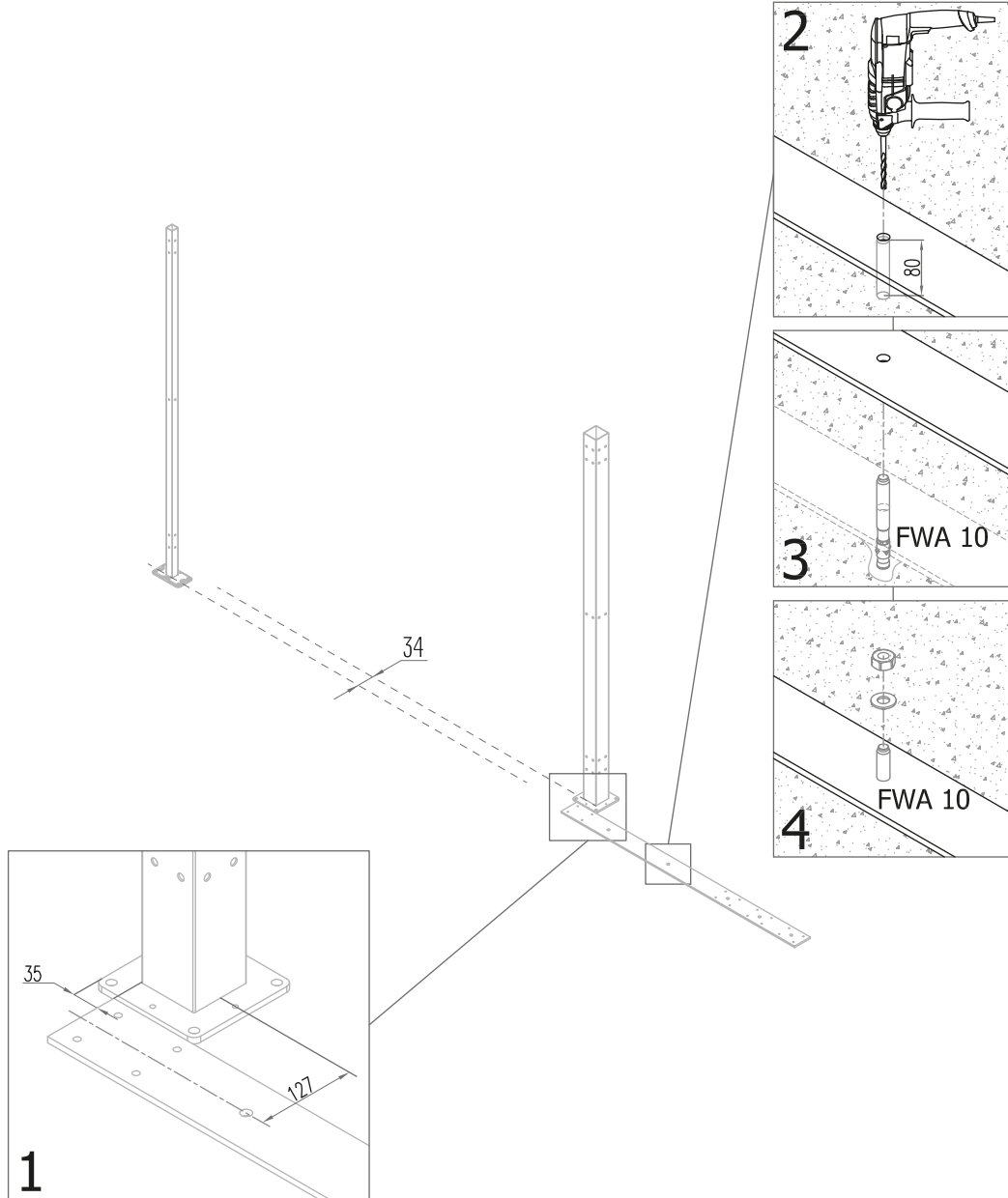

M10	M8(G,P)	Nm = 7÷8
M8(F,Q,Y,Z)		Nm = 20
M6		Nm = 10
M5		Nm = 5

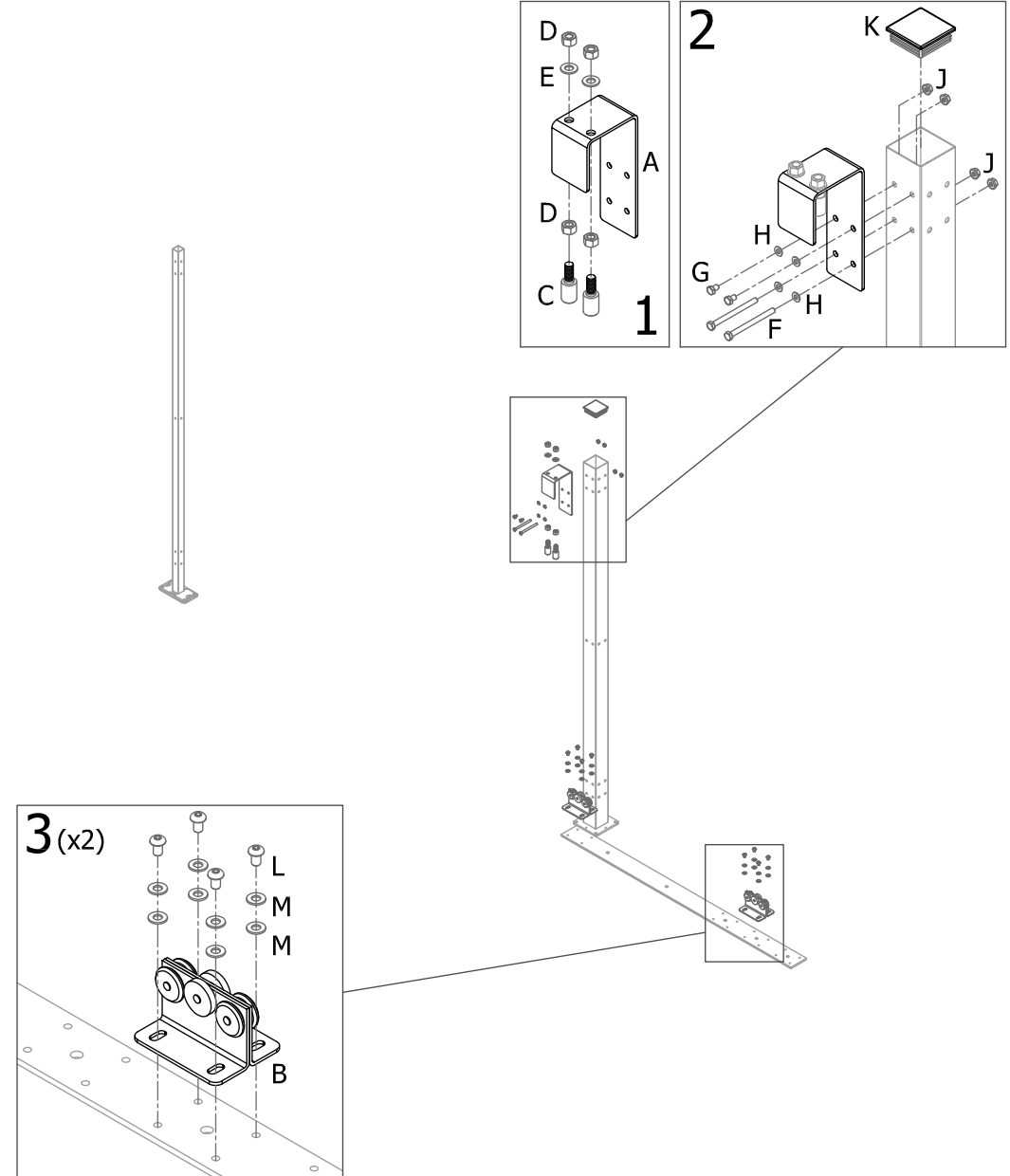



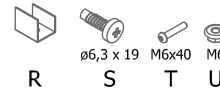
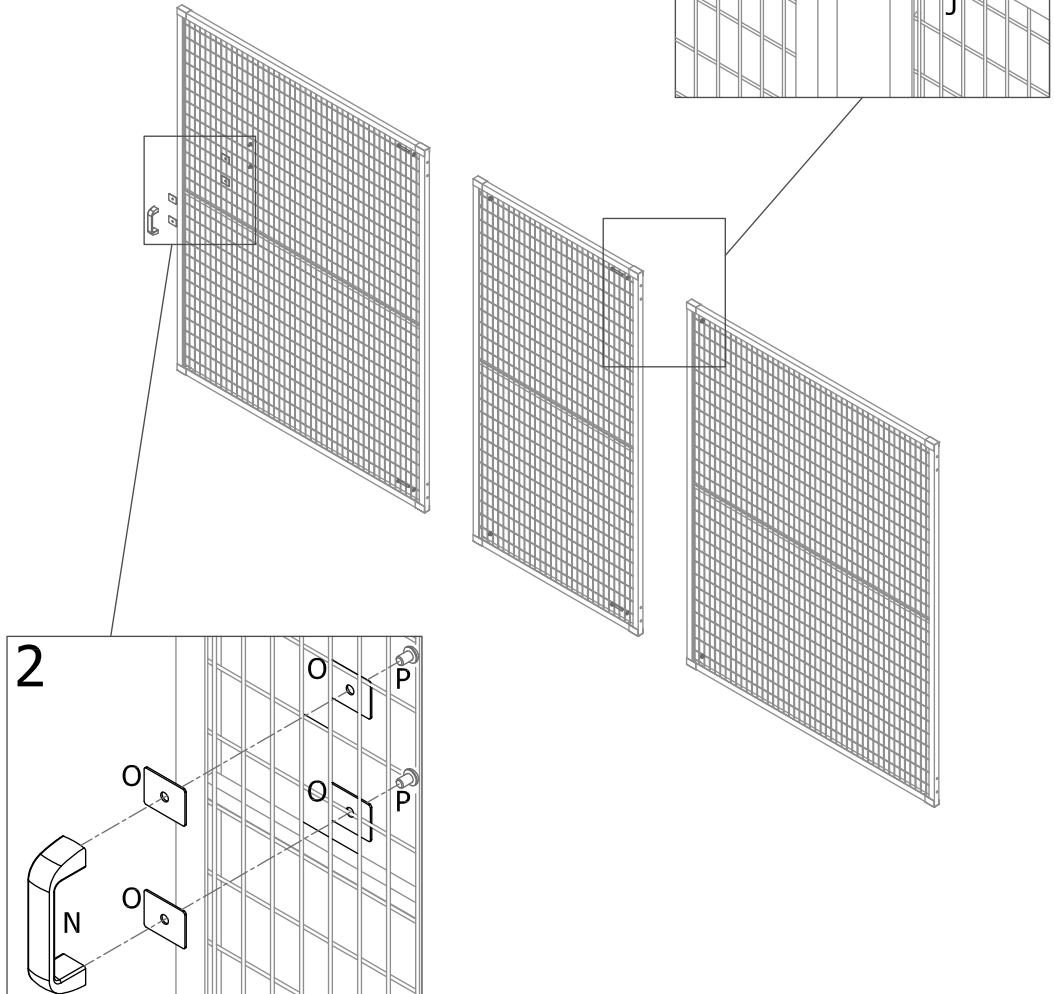

M10	M8(G,P)	Nm = 7÷8	
M8(F,Q,Y,Z)	Nm = 20		
M6	Nm = 10		
M5	Nm = 5		

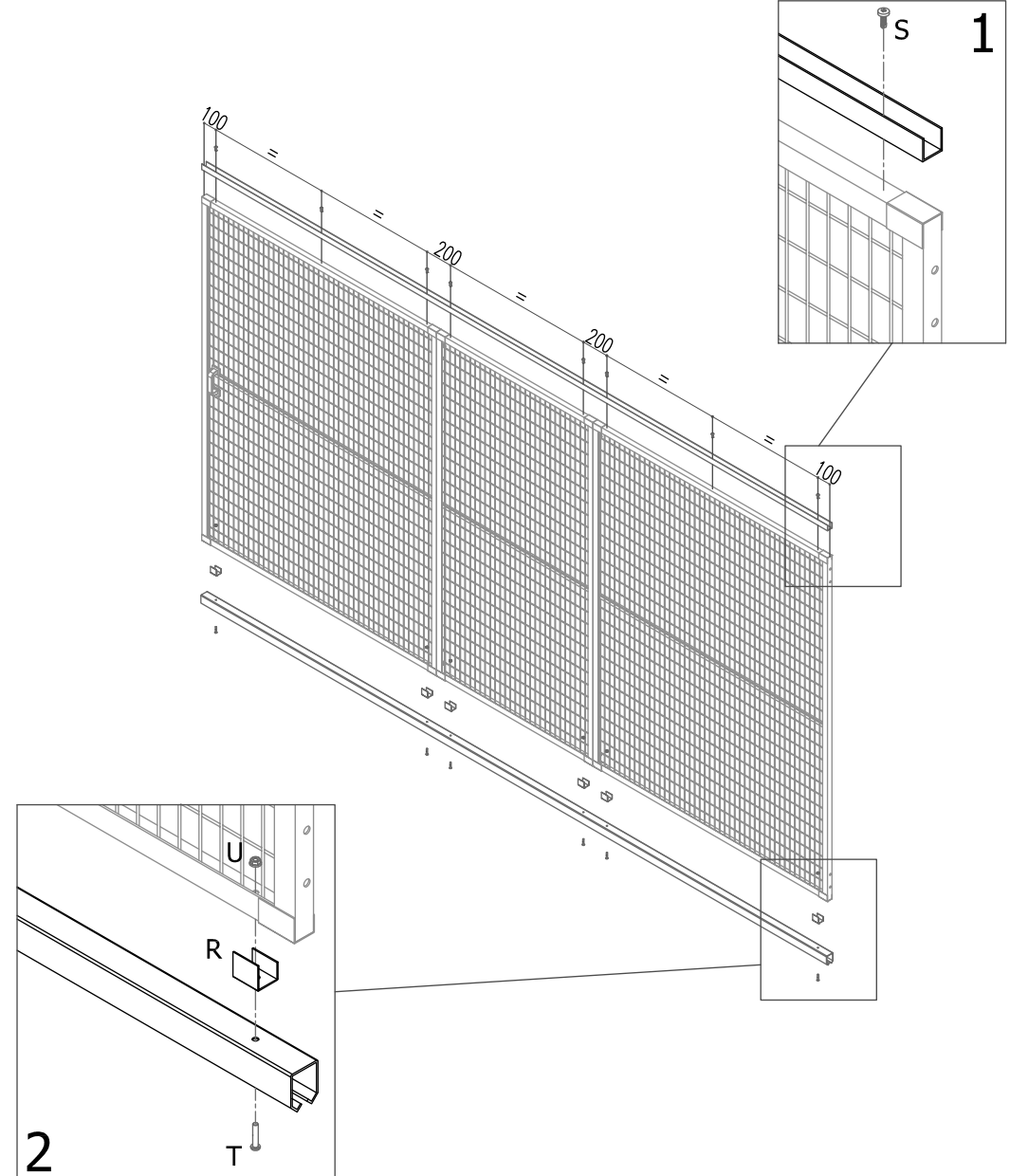

M10	M8(G,P)	Nm = 7÷8	
M8(F,Q,Y,Z)	Nm = 20		
M6	Nm = 10		
M5	Nm = 5		



M10	M8(G,P)	Nm = 7÷8	
M8(F,Q,Y,Z)	Nm = 20		
M6	Nm = 10		
M5	Nm = 5		

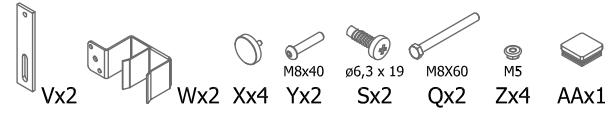
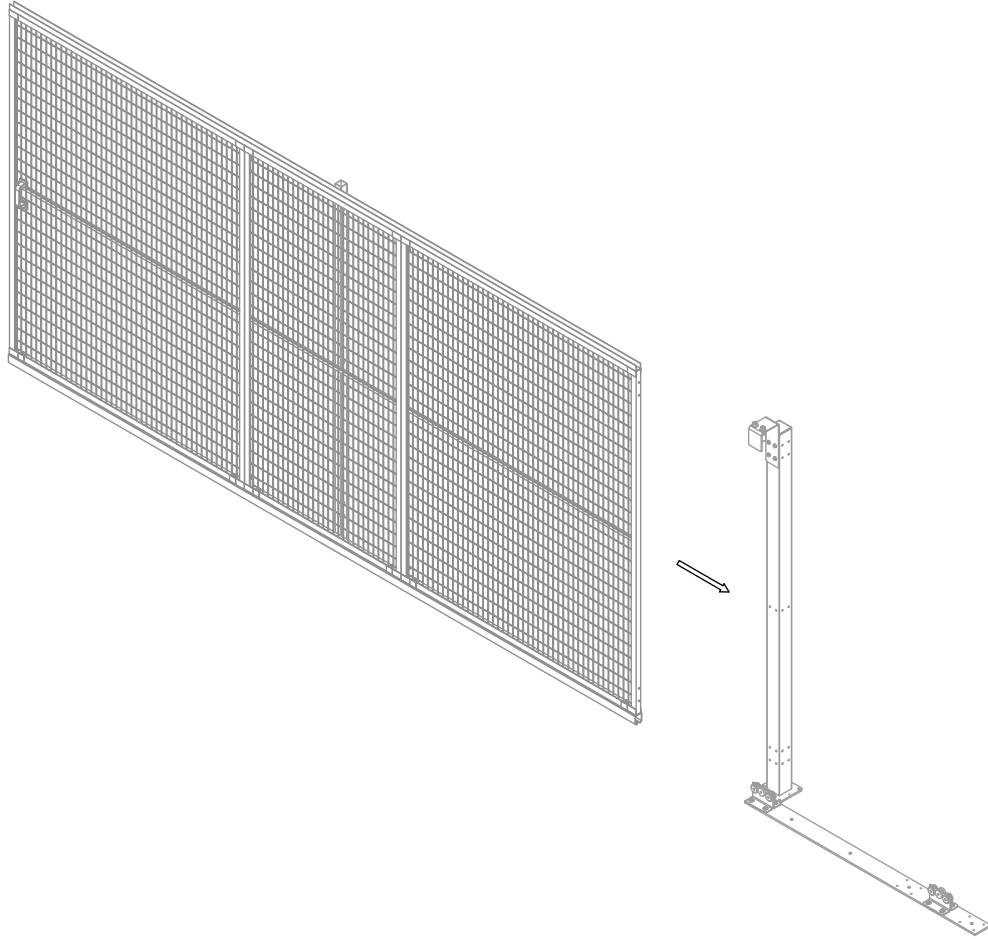

M10	M8(G,P)	Nm = 7÷8	
M8(F,Q,Y)	Nm = 20		
M6	Nm = 10		
M5	Nm = 5		

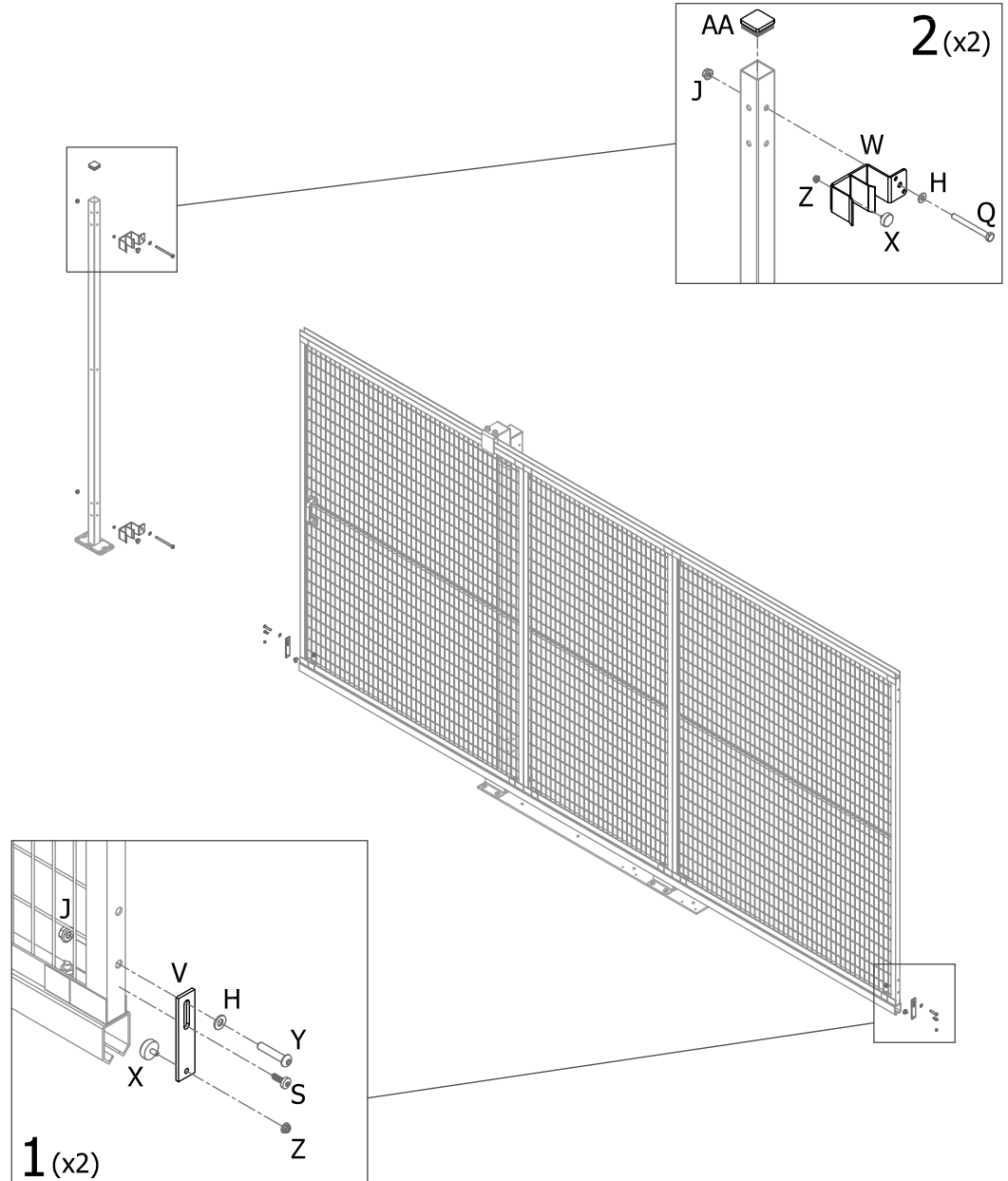

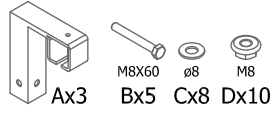

M8(B,G)	Nm = 20	
M8(L)	Nm = 7±8	
M5	Nm = 5	

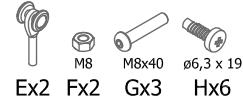
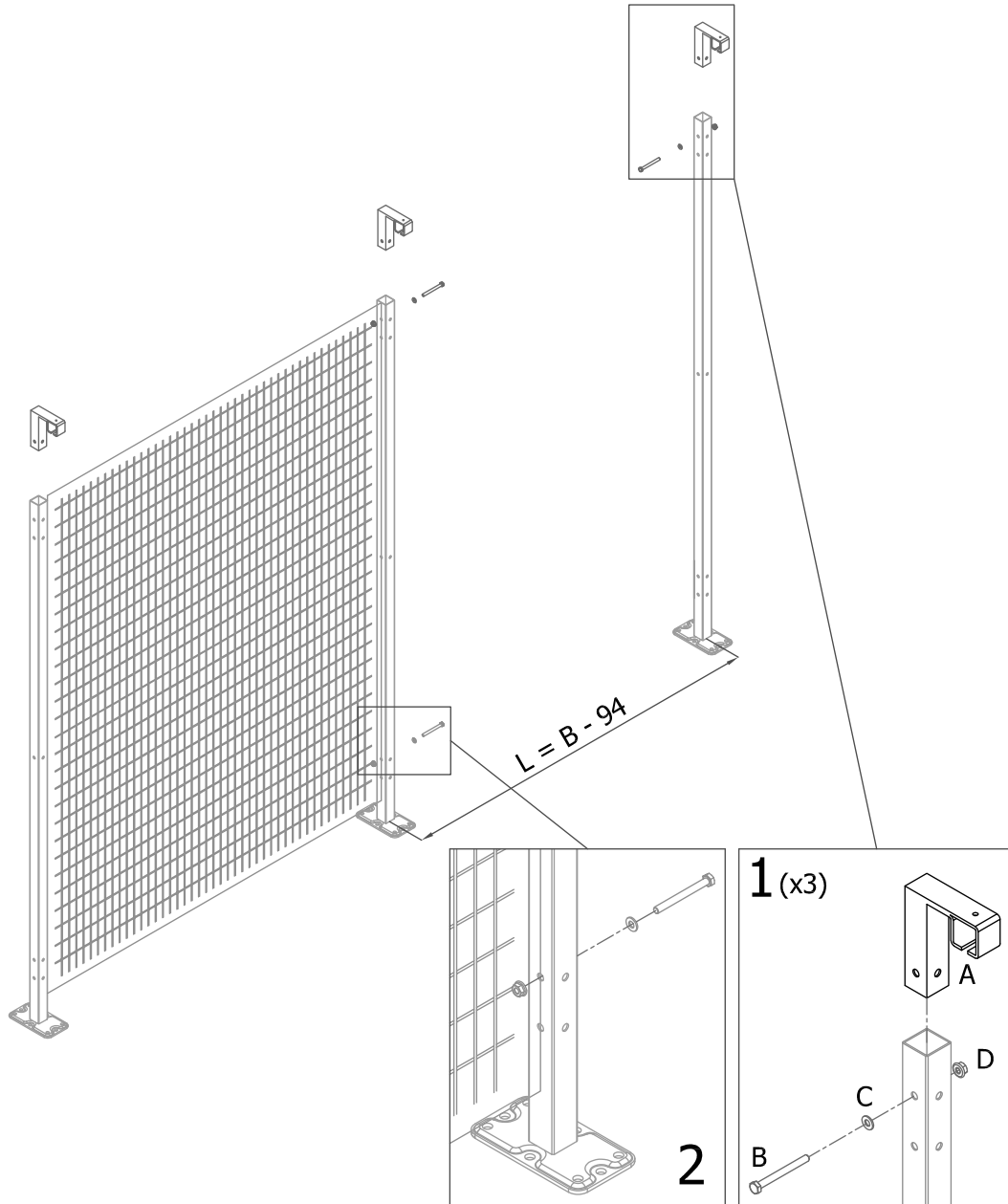

M8(B,G)	Nm = 20	
M8(L)	Nm = 7±8	
M5	Nm = 5	

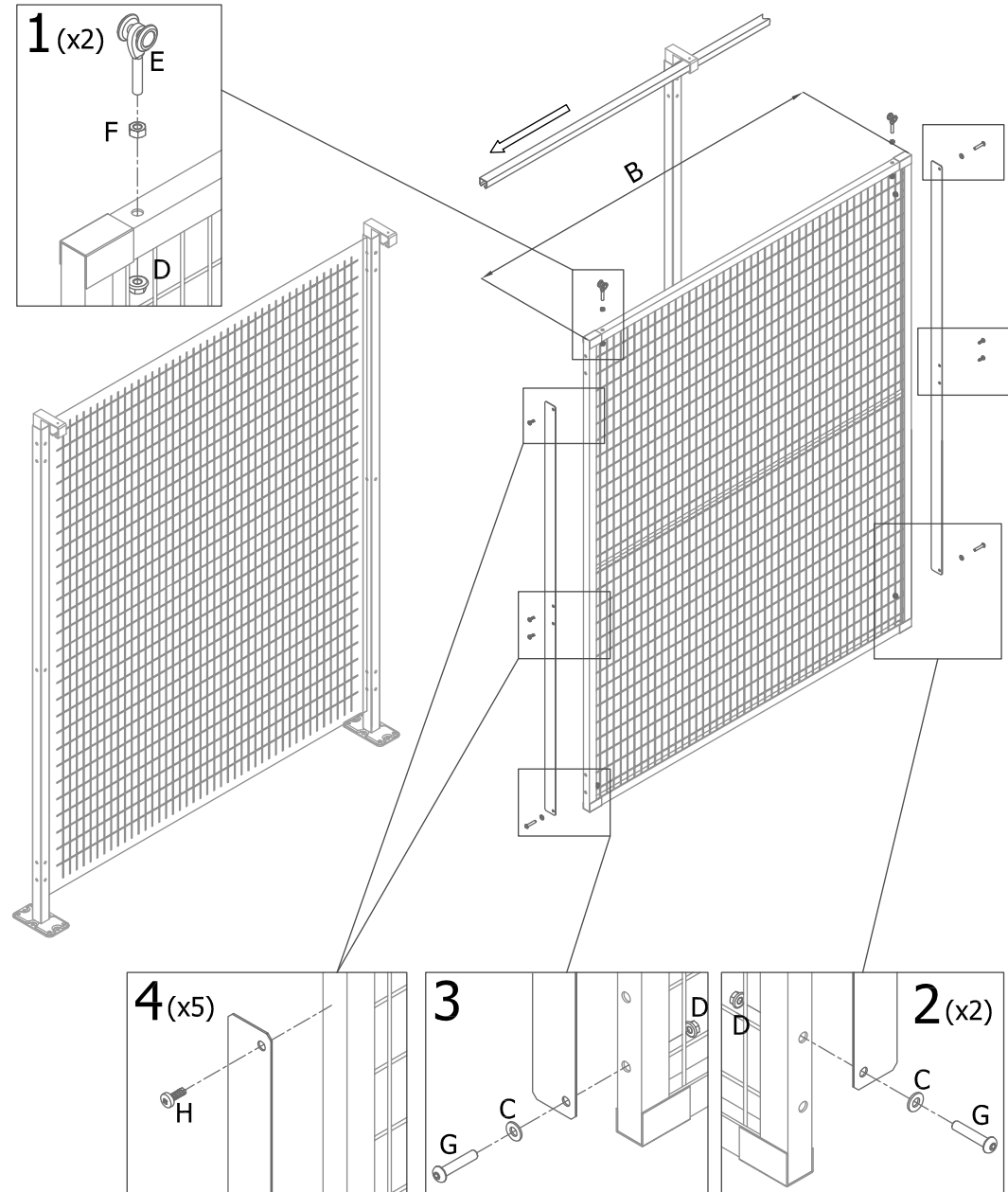

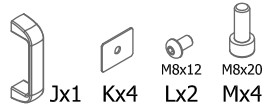

M8(B,G)	Nm = 20	
M8(L)	Nm = 7±8	
M5	Nm = 5	

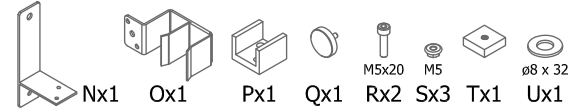
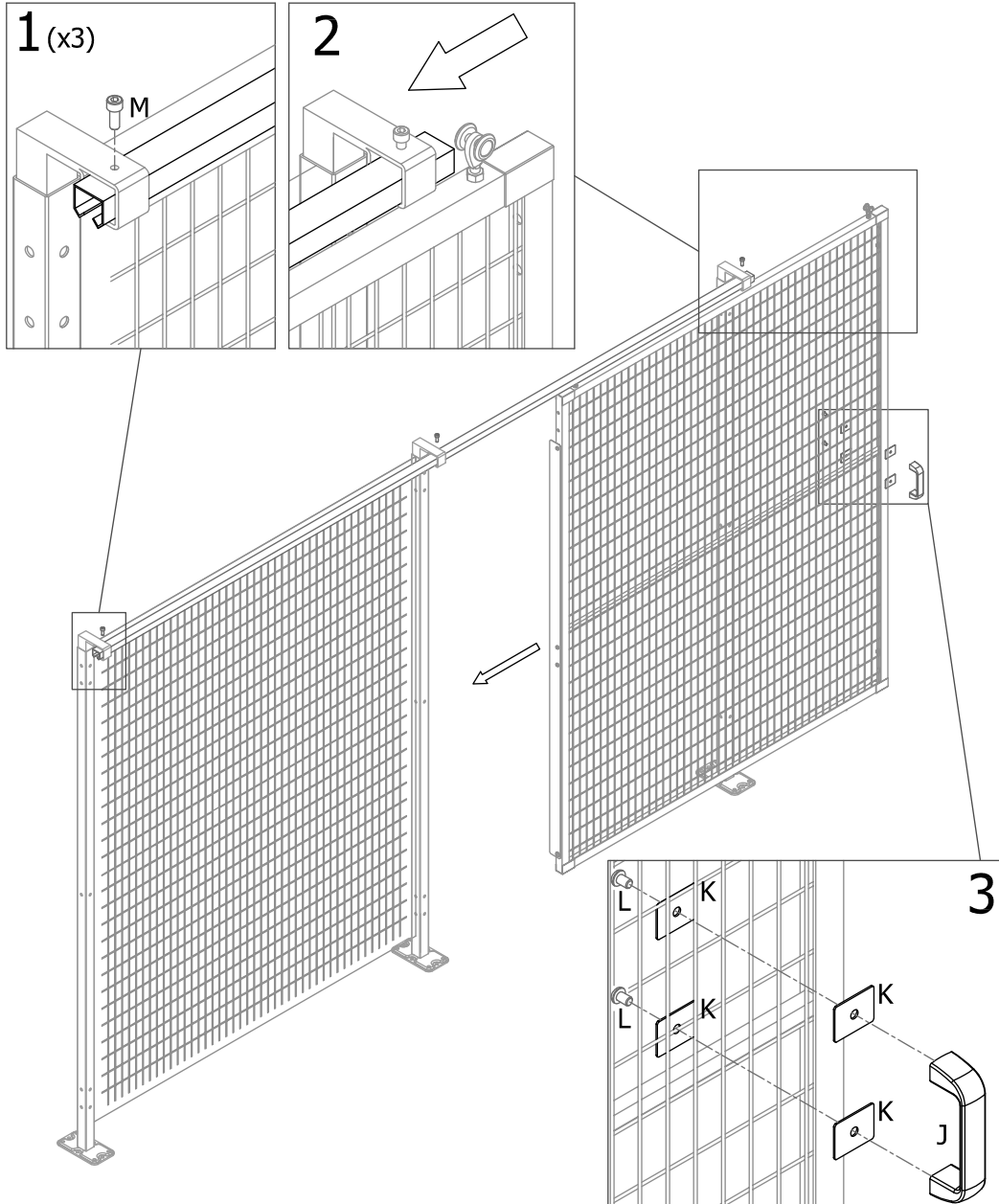

M8(B,G)	Nm = 20	
M8(L)	Nm = 7±8	
M5	Nm = 5	

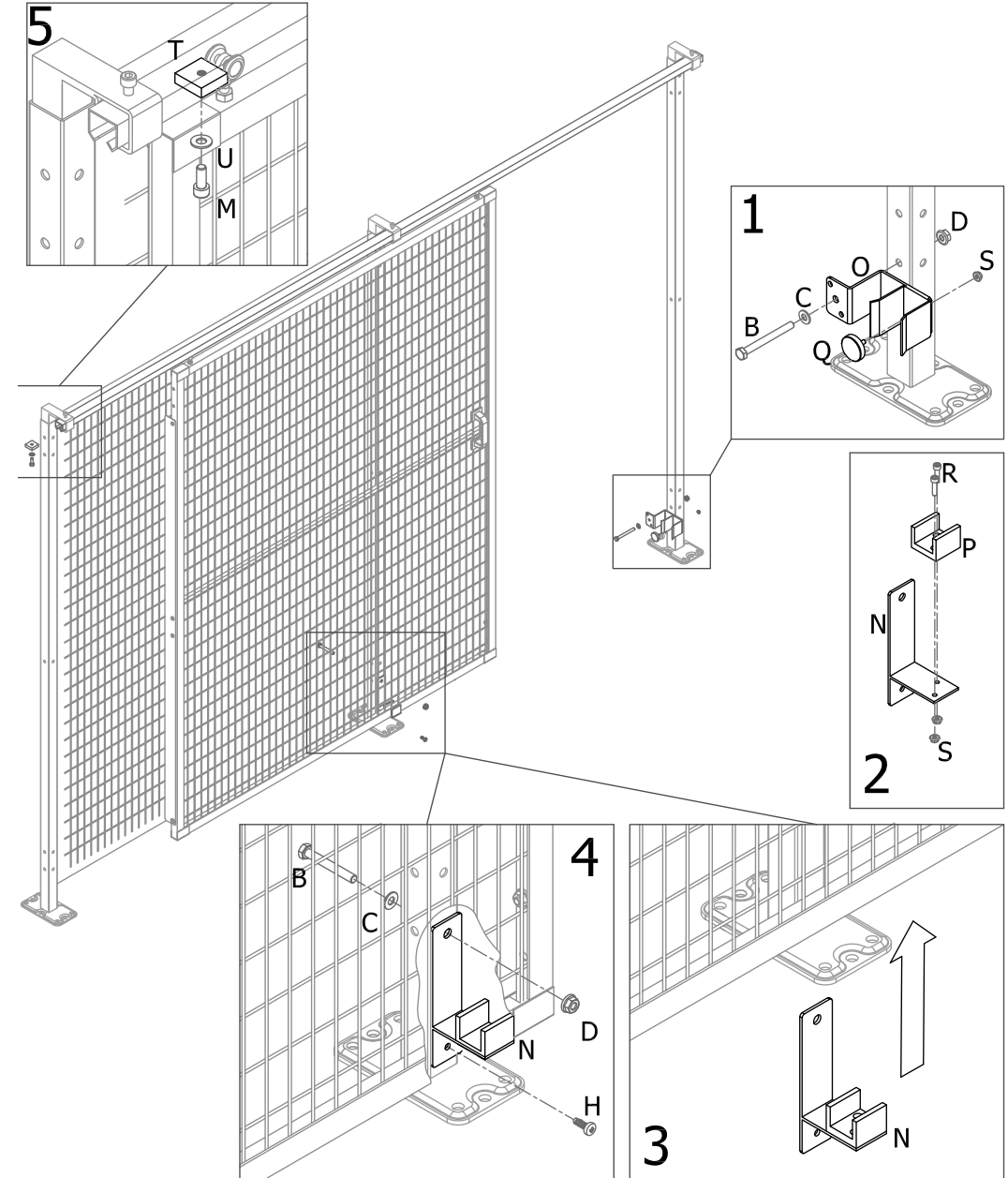

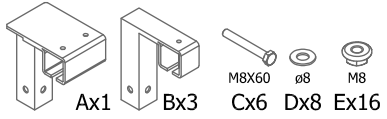

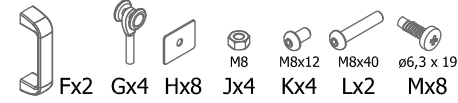
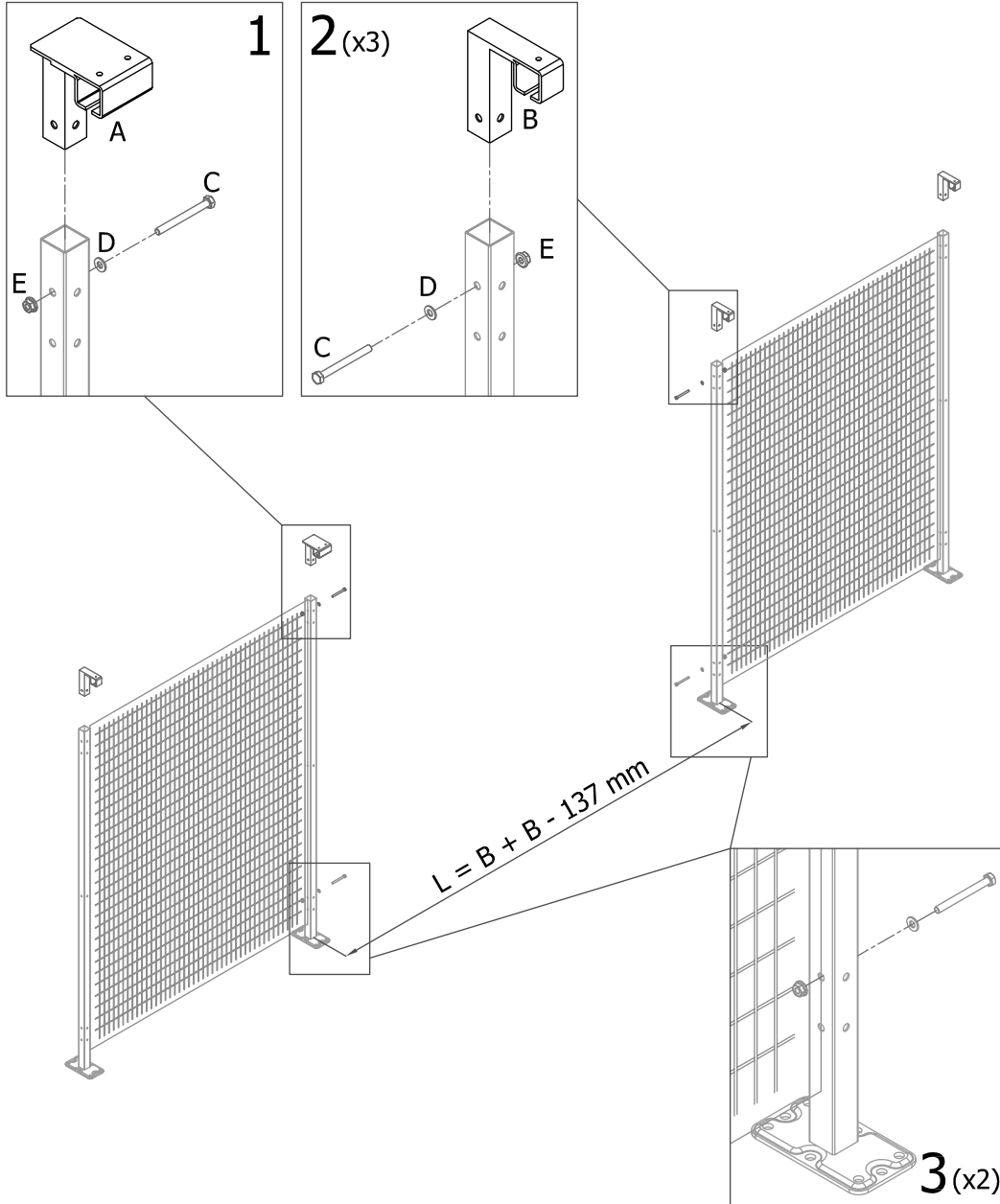

M8(C,L,W)	Nm = 20	
M8(K)	Nm = 7±8	
M5	Nm = 5	

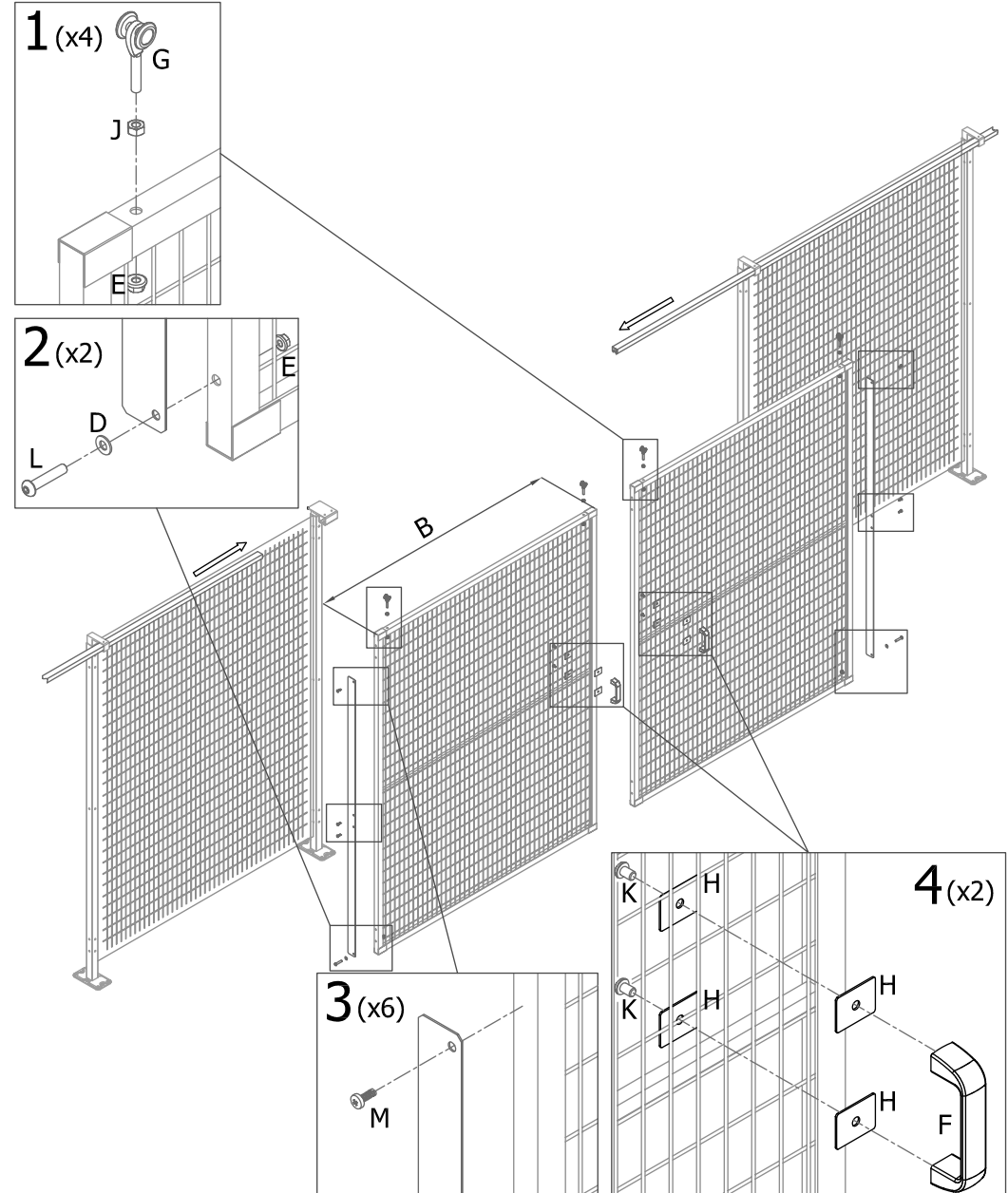

M8(C,L,W)	Nm = 20	
M8(K)	Nm = 7±8	
M5	Nm = 5	



M8x20  
Nx9

M8(C,L,W)	Nm = 20	
M8(K)	Nm = 7±8	
M5	Nm = 5	

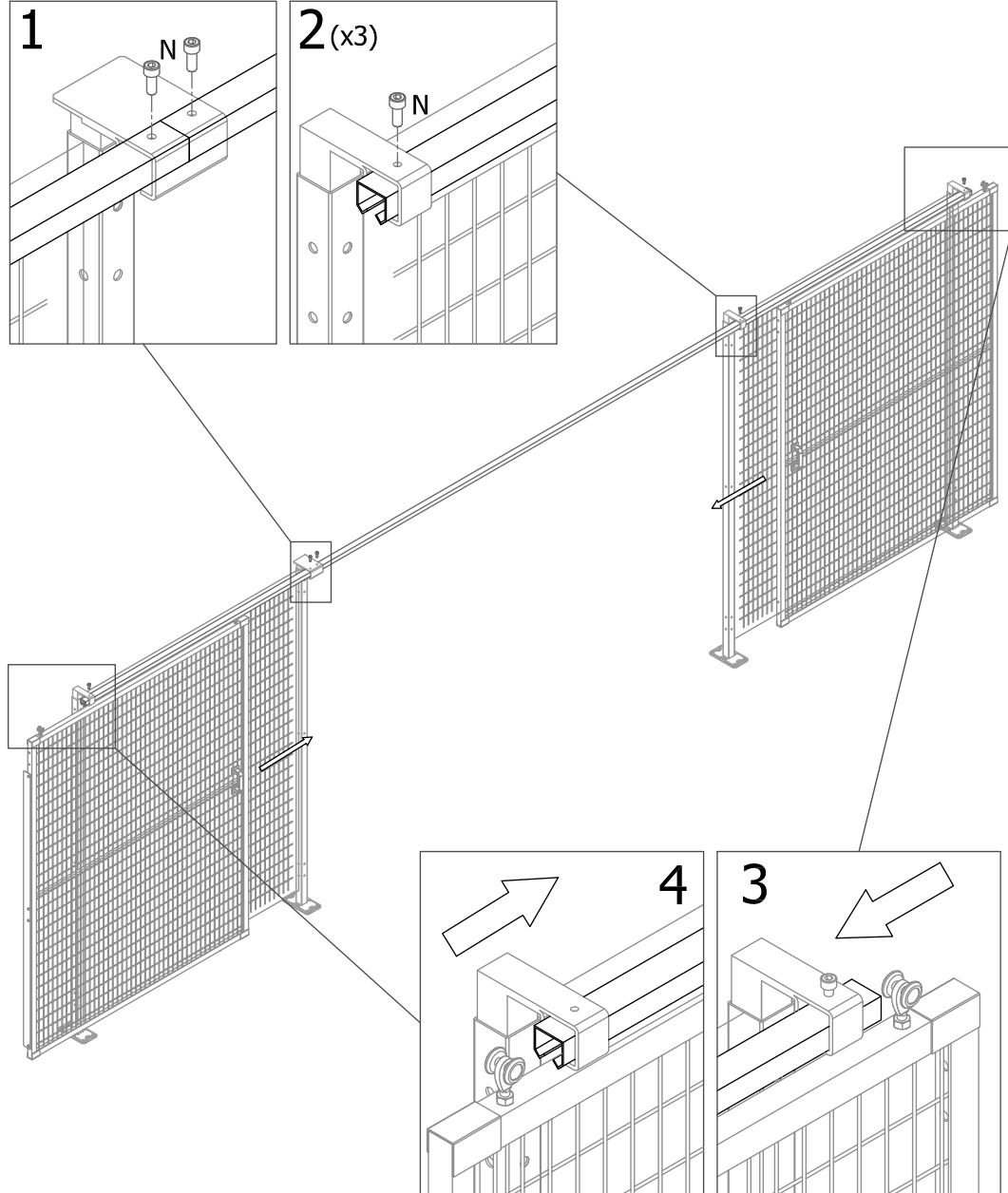

Ox2 Px2 Qx2 M5x20 M5 Tx4 Ux4 Vx1 Wx4

M8(C,L,W)	Nm = 20	
M8(K)	Nm = 7±8	
M5	Nm = 5	

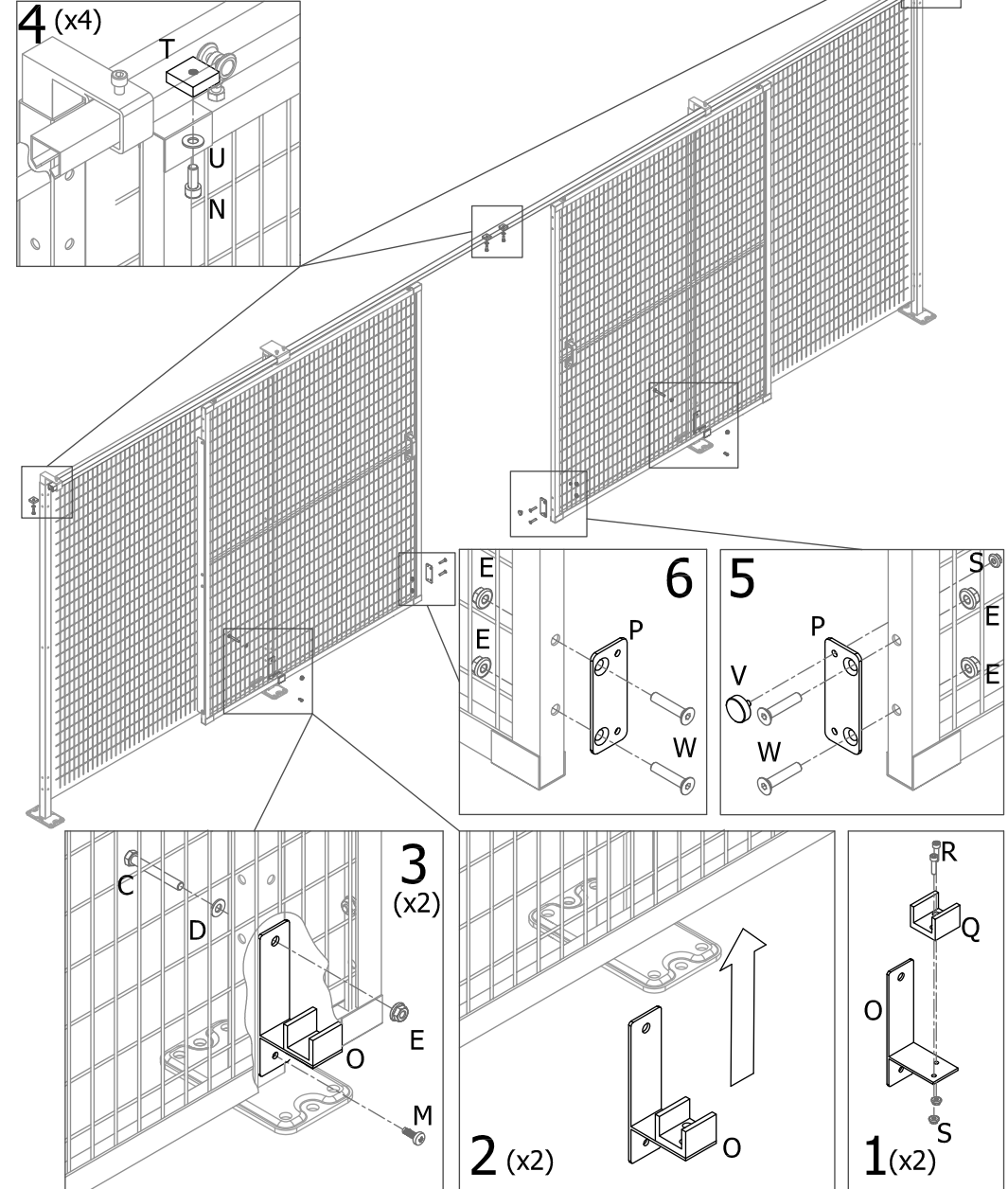





M8 Nm = 20 

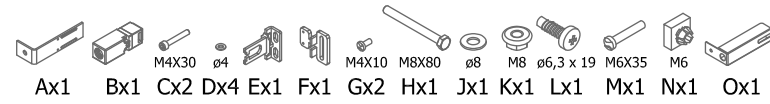
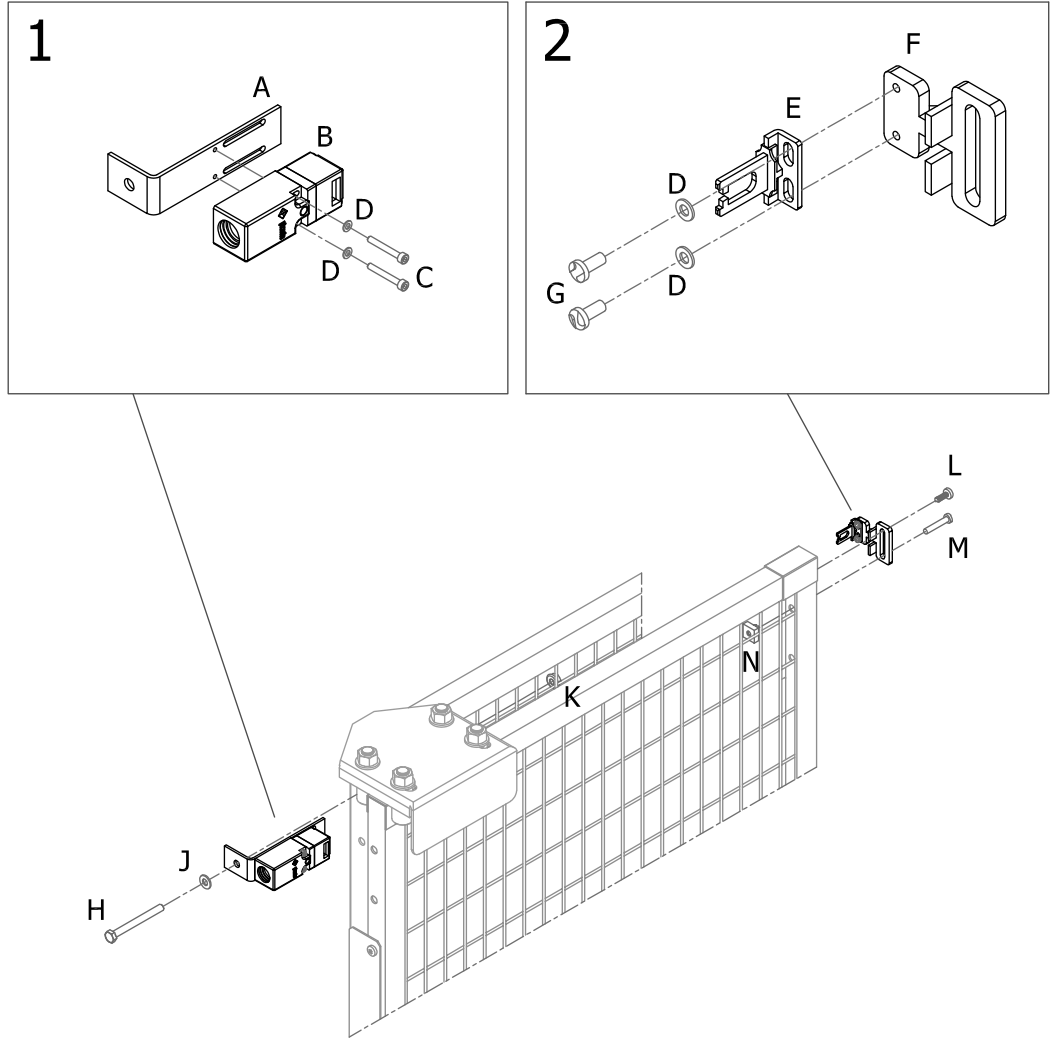

M8 Nm = 20 

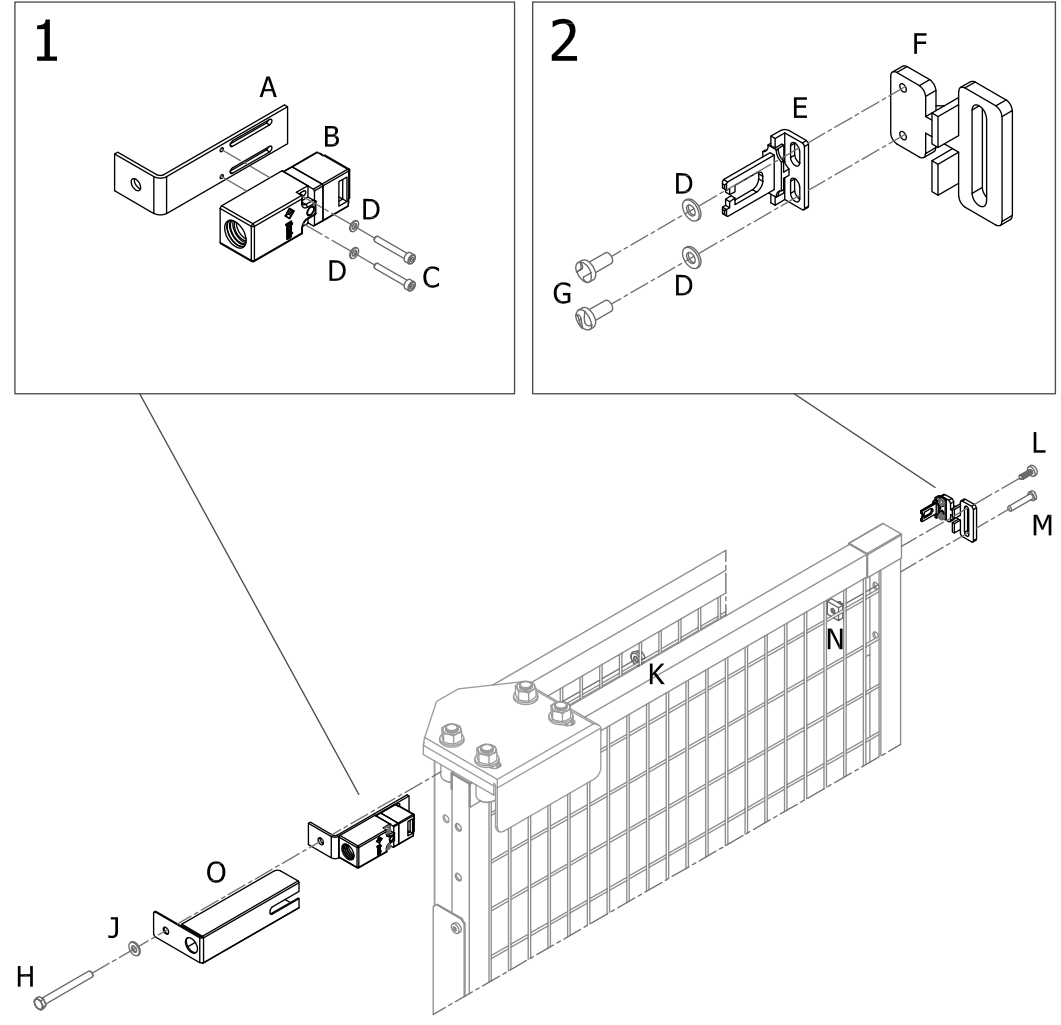

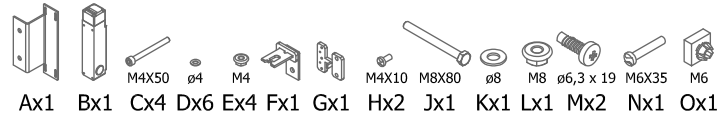

M8 Nm = 20

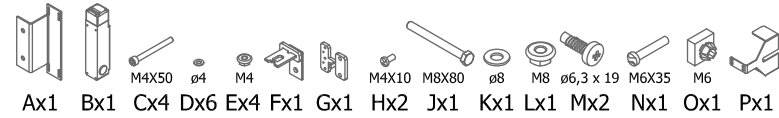
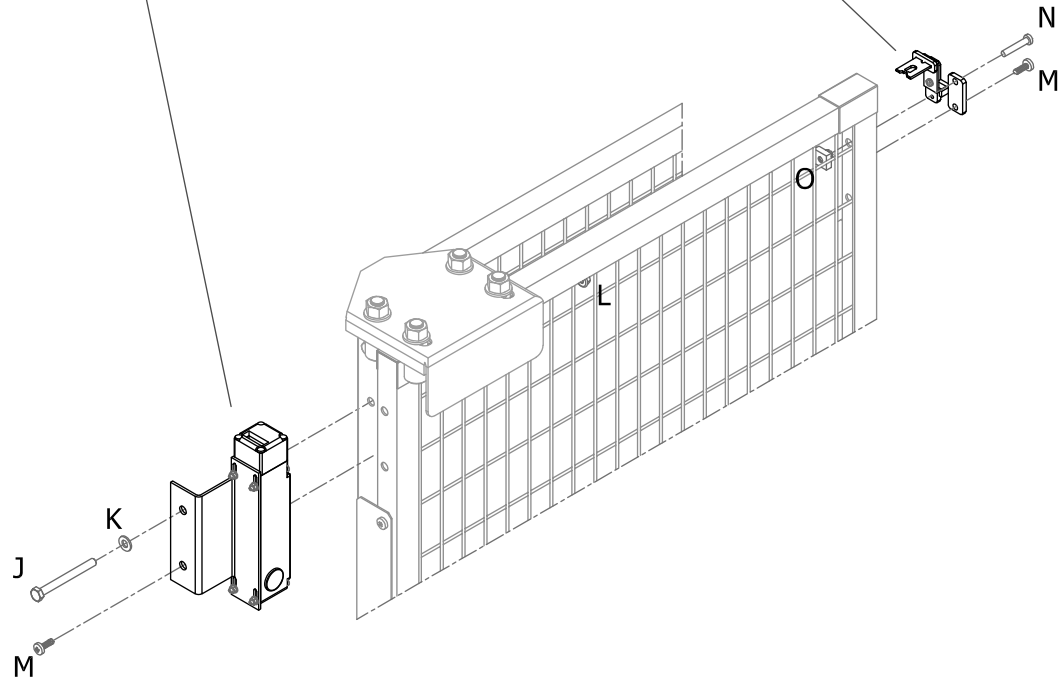
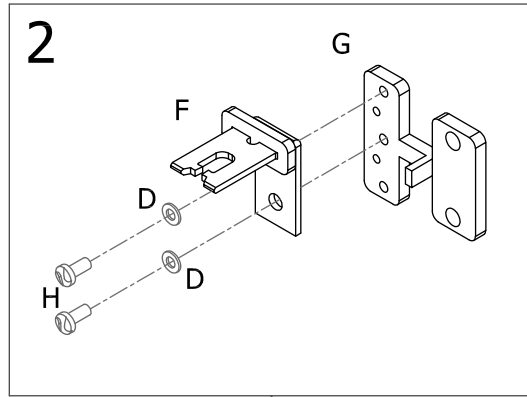
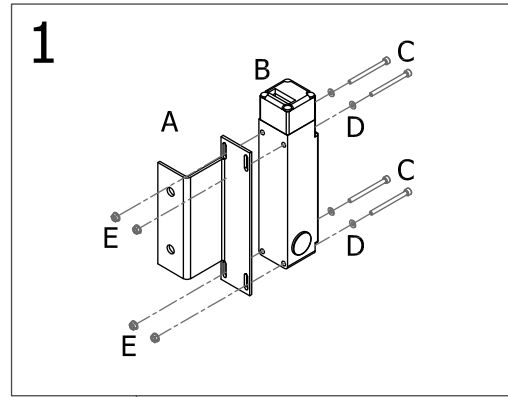

M8 Nm = 20

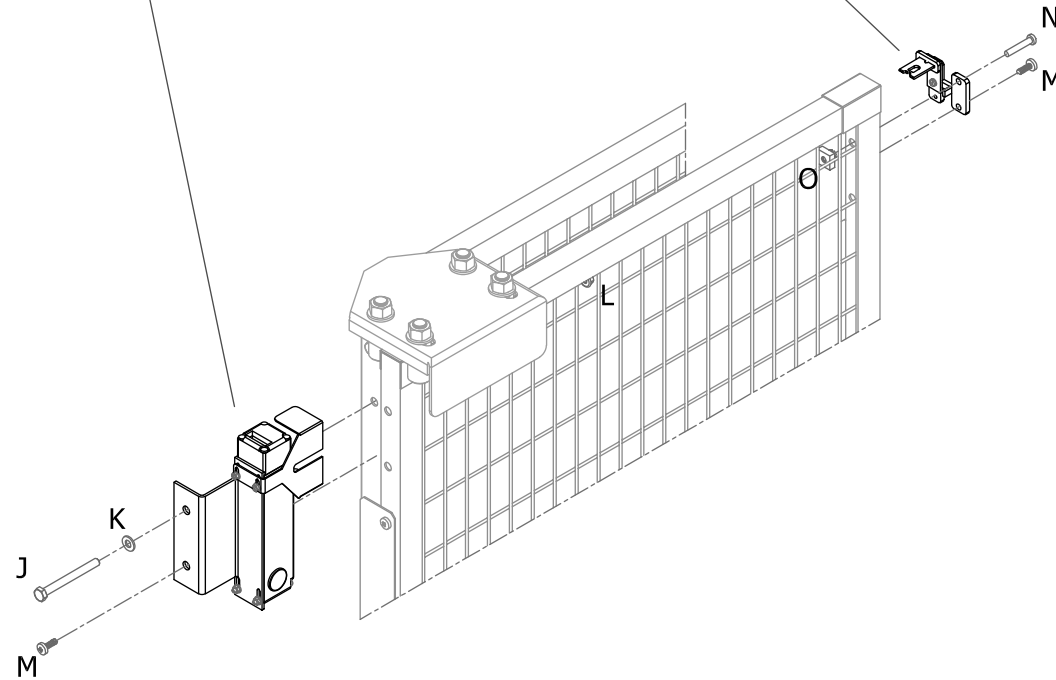
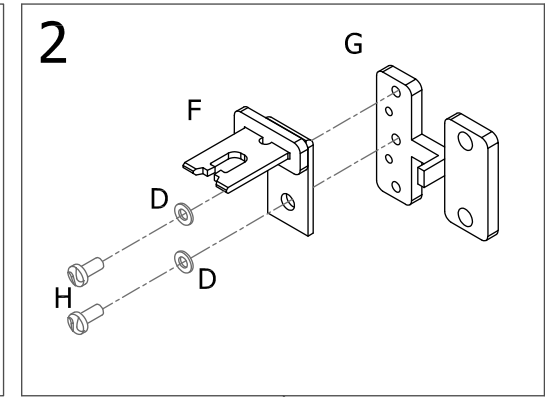
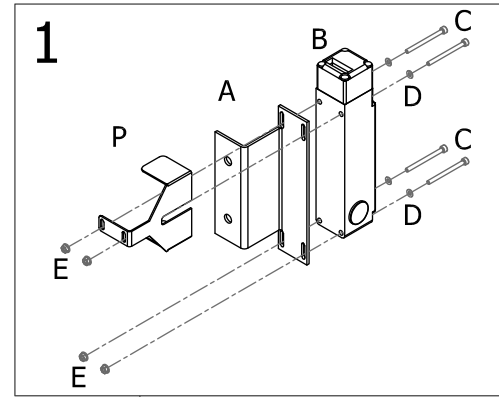

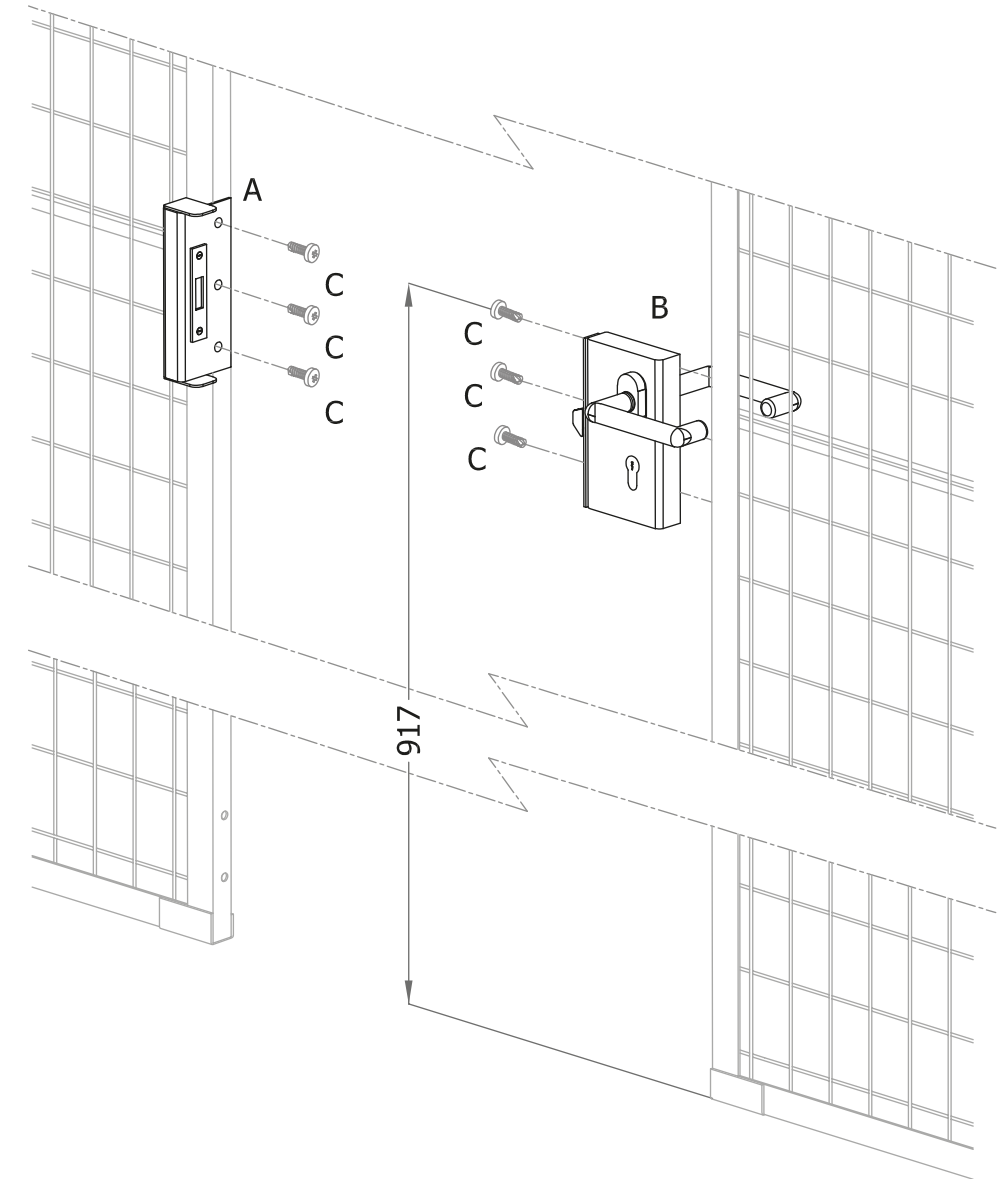
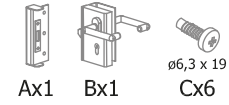
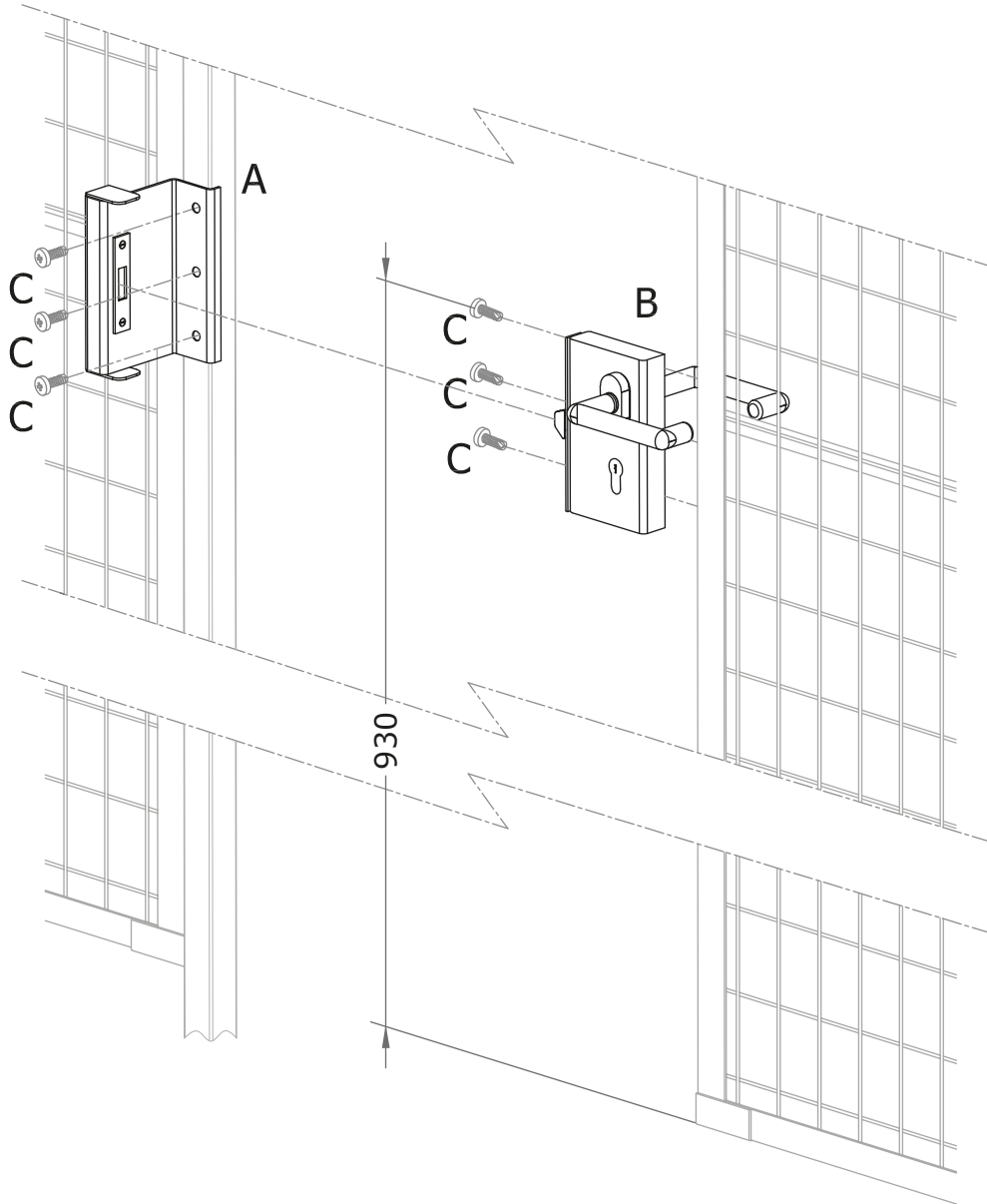
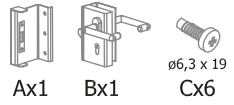



## DICHIARAZIONE CE DI CONFORMITÀ

Il sottoscritto, in qualità di legale rappresentante della :

### PROTEC Srl

Via Zamenhof, 363  
36100 Vicenza Italy

dichiara che i sistemi di barriere distanziatrici composte da pannelli modulari fissi e mobili.

## NOVATEK, ECOTEK, TECHNO Ø3-Ø4 (\*)

rispettano i requisiti loro applicabili di cui alla direttiva macchine 2006/42/CE.  
rispettano i requisiti loro applicabili di cui alla Norma EN ISO 14120 e EN ISO 14119.

(\*) Cfr. elenco componenti di cui :  
alla pag. 8 del seguente manuale sistema NOVATEK  
alla pag. 9 del seguente manuale sistema ECOTEK  
alla pag. 10 del seguente manuale sistema TECHNO Ø3  
alla pag. 11 del seguente manuale sistema TECHNO Ø4

La persona autorizzata alla costituzione del fascicolo tecnico è

### PROTEC Srl

Via Zamenhof, 363  
36100 Vicenza Italy

Vicenza, 01-01-2022

L'Amministratore Delegato  
Michele Dalla Mora

### PROTEC Srl

36100 VICENZA – ITALY  
Via Zamenhof, 363  
Tel. +39 0444 246080  
Fax +39 0444 240251  
Info.protec@grupposicura.it  
PI. C.F. e N° Reg. Impr. di Vicenza: 02572680243

### 1. MANIPOLAZIONE E SPOSTAMENTO

Si ricorda che la manipolazione/sollevamento dei ripari deve essere fatta in condizioni di piena sicurezza e senza conseguenze fisiche rilevanti per un solo addetto, fino ad un peso non superiore a 25 Kg. I ripari di peso superiori a 25 Kg o di dimensioni tali da non consentire una presa agevole da parte di un singolo addetto (larghezza non superiore a 1500 mm.) vanno sollevati e spostati mediante l'uso di attrezzature di sollevamento.

Protec consiglia di utilizzare un dispositivo con aggancio dall'alto (es. paranco, carroponete...) applicando il gancio nella zona centrale come da disegno qui di seguito:

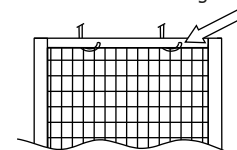

Protec sconsiglia di utilizzare muletti o altri dispositivi di sollevamento dal basso in quanto non è possibile garantire una ragionevole stabilità durante lo spostamento.

### 2. MONTAGGIO (vedi manuale di istruzioni)

### 3. INSTALLAZIONE DEL SISTEMA

Le barriere distanziatrici perimetrali realizzate mediante i ripari NOVATEK, TECHNO Ø3-Ø4, ECOTEK devono rispettare possibilmente la seguente normativa di riferimento :

UNI EN 13857 Distanze di sicurezza per impedire il raggiungimento di zone pericolose con gli arti superiori e inferiori.

Ovvero il posizionamento dei ripari rispetto ai centri di pericolo dovrà rispettare le misure previste dalla suddetta norma in funzione dell'altezza dei singoli pannelli dell'altezza dei centri di pericolo rispetto alla zona calpestabile e delle dimensioni della rete.

Si sottolinea che il rispetto delle misure previste dalla norma cui sopra non è cogente; tuttavia se l'utilizzatore deciderà di scegliere una soluzione diversa potrà essere chiamato in sede di controllo a dimostrare che le modalità di installazione garantiscono il medesimo livello di sicurezza previsto dalle norme armonizzate.

PROTEC Srl in qualità di esclusivo costruttore dei ripari non può assumersi la responsabilità relativa alla configurazione del sistema delle barriere distanziatrici la quale cadrà esclusivamente sull'utilizzatore. Si rammenta infine l'obbligo inderogabile di fissare i montanti al suolo.

### 4. DESTINAZIONE D'USO

I ripari del sistema NOVATEK, TECHNO Ø3-Ø4, ECOTEK sono destinati all'uso di barriere distanziatrici perimetrali per le zone di macchina che presentano centri di pericolo. Essi sono stati dimensionati in relazione alle sollecitazioni ragionevolmente prevedibili (zone esterne alla protezione) e da quelle interne generate dall'eventuale distacco di parti in lavorazione e/o pezzi di macchina. Per quanto riguarda le caratteristiche dimensionali vedere "Manuale di istruzioni".

Il cliente è tenuto a verificare che le caratteristiche del prodotto NOVATEK, TECHNO Ø3-Ø4, ECOTEK, siano compatibili con la specifica applicazione prevista dal cliente stesso. In particolare che la resistenza meccanica sia sufficiente a sopportare le sollecitazioni prevedibili durante l'uso, ad esempio in caso di urti accidentali o proiezione di materiali.

Il prodotto è destinato ad essere utilizzato in ambiente asciutto e protetto dagli agenti atmosferici.

### PROTEC Srl

36100 VICENZA – ITALY  
Via Zamenhof, 363  
Tel. +39 0444 246080  
Fax +39 0444 240251  
Info.protec@grupposicura.it  
PI. C.F. e N° Reg. Impr. di Vicenza: 02572680243

## 5. CARATTERISTICHE TECNICHE AGGIUNTIVE

Il pannello NOVATEK è costruito da un profilo per serramenti 11A e con traverso centrale in tubo 15x15, mentre la tamponatura è in rete rettangolare 32x67 filo ø3mm.

Il pannello ECOTEK è costruito da un profilo 10x25 e con traverso centrale in tubo 10x10, mentre la tamponatura è in rete rettangolare 32x67 filo ø3mm.

Il pannello TECHNO ø3 è costruito da un foglio in rete 32x67 filo ø3mm irrigidito mediante n.3 nervature orizzontali a forma di "omega".

Il pannello TECHNO ø4 è costruito da un foglio in rete 32x67 filo ø4mm irrigidito mediante n.3 nervature orizzontali a forma di "omega".

I montanti dei sistemi sono in tubo 40x40 o 40x80 o 80x80 sp.2mm preforato.

Si segnala inoltre che gli eventuali frammenti generati all'interno della zona segregata e proiettati verso l'esterno, le dimensioni dei quali risultino inferiori a quelle della luce della maglia, non potranno essere tratti dai ripari medesimi.

Sarà compito del committente realizzare un adeguato ancoraggio dei montanti al suolo.

## 6. UTILIZZO DEI RIPARI

Le porte (ripari mobili) presenti nei sistemi di barriere distanziatrici sono destinate al fine esclusivo di gestire l'accesso regolamentato in piena sicurezza alla zona segregata.

Tale condizione può essere garantita dalla presenza dei microinterruttori di sicurezza sulle porte che provvedono all'interruzione delle funzioni pericolose all'interno dell'area o sistemi alternativi la cui valutazione è a cura del cliente.

L'uso corretto della porte prevede l'arresto della macchina o delle sue funzioni pericolose prima dell'apertura della stessa.

E' vietato provocare l'arresto della macchina mediante l'apertura del riparo.

## 7. MANUTENZIONE PERIODICA

Gli interventi periodici di manutenzione da effettuare sui ripari sono di natura meccanica e elettrica; l'esecuzione degli stessi con frequente periodicità garantisce il mantenimento del livello di sicurezza previsto.

Interventi di natura meccanica :

1. Controllo periodico del corretto serraggio delle viti di ancoraggio del pannello
2. Controllo periodico del corretto serraggio dei sistemi di fissaggio al suolo dei montanti
3. Controllo dei punti di saldatura della rete al telaio
4. Controllo periodico del funzionamento meccanico della porta

Interventi di natura elettrica :

1. Verifica periodica del corretto funzionamento del microinterruttore all'apertura della porta.

## 8. USO SCORRETTO

Sono usi scorretti e pertanto vietati:

- arrampicarsi e scavalcare ed in generale eludere i ripari;
- appendere o fissare carichi che possano compromettere la stabilità dei ripari;
- appendere o fissare ai ripari apparecchi elettrici privi di protezione contro i contatti indiretti.
- qualsiasi manomissione dei ripari (es. taglio della rete per la creazione di fessure, allentamento dei fissaggi, ecc.) e degli interblocchi delle porte.

Prima di eseguire operazioni non espressamente previste nel presente manuale, contattare l'ufficio tecnico di Protec srl.

### PROTEC Srl

36100 VICENZA – ITALY  
Via Zamenhof, 363  
Tel. +39 0444 246080  
Fax +39 0444 240251  
Info.protec@grupposicura.it  
PI. C.F. e N° Reg. Impr. di Vicenza: 02572680243



## CE DECLARATION OF CONFORMITY

The undersigned, as legal representative of the :

### PROTEC Srl

Via Zamenhof, 363  
36100 Vicenza Italy

declares that the barrier system consisting in fixed / mobile / interconnected modular panels

## NOVATEK, ECOTEK, TECHNO ø3-ø4 (\*)

fulfil all the relevant provisions of "Machinery Directive" 2006/42/CE.

fulfil all the relevant provisions of Norm EN ISO 14120 and EN ISO 14119.

(\*) see list of components referred to :  
on page 8 of the following manual (NOVATEK system)  
on page 9 of the following manual (ECOTEK system)  
on page 10 of the following manual (TECHNO ø3 system)  
on page 11 of the following manual (TECHNO ø4 system)

Person authorised to compile the technical file :

### PROTEC Srl

Via Zamenhof, 363  
36100 Vicenza Italy

Vicenza, 01-01-2022

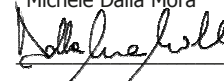
CEO  
Michele Dalla Mora  

### PROTEC Srl

36100 VICENZA – ITALY  
Via Zamenhof, 363  
Tel. +39 0444 246080  
Fax +39 0444 240251  
Info.protec@grupposicura.it  
PI. C.F. e N° Reg. Impr. di Vicenza: 02572680243



**1. HANDLING AND DISPLACEMENT**

Please note that the handling / lifting of the guards must be done in conditions of complete safety and without significant physical consequences for a single person, up to a weight not exceeding 25 kg. The guards weighing more than 25 kg or of such dimensions as to not allow easy handling by a single person (width not exceeding 1500 mm.) Should be lifted and moved by the use of lifting equipment. Protec recommends using a device with a hook from the top (eg hoist, bridge crane ...) by applying the hook in the central area as shown in the drawing below:

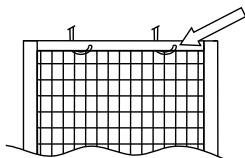

Protec does not recommend using forklifts or other lifting devices from the ground as it is not possible to guarantee reasonable stability during movement.

**2. MOUNTING (see instruction manual)****3. SYSTEM INSTALLATION**

The perimeter protection barriers made using the NOVATEK, TECHNO Ø3-Ø4, ECOTEK guards must comply with the following reference standards:

UNI EN 13857 Safety distances to prevent the achievement of dangerous areas with the upper and lower zones.

The positioning of the guards with respect to the danger zones must comply with the measures marked by the aforesaid standard, according to the height of the individual panels of the height of the danger points with respect to the walkable area and the dimensions of the grid.

It is underlined that compliance with the measures provided for, by the aforementioned regulation is not binding; however, if the user decides to choose a different solution, he can be called to check that the installation methods guarantee the same level of safety as the harmonized standards.

PROTEC Srl as sole manufacturer of the guards will not assume any responsibility for the configuration of the protection barrier system, as it will fall exclusively on the user.

Finally, it is recalled the mandatory obligation to fix the posts to the ground.

**4. USE DESTINATION**

The NOVATEK, TECHNO Ø3-Ø4, ECOTEK barrier system are designed to use perimeter spacers for machine zones with danger points. They have been sized in relation to the reasonably foreseeable stresses (areas outside the protection) and the internal ones generated by the possible separation of parts being machined and / or machine parts.

For the dimensional characteristics see "Instructions manual".

The customer must check that the features of NOVATEK, TECHNO Ø3-Ø4, ECOTEK products are compatible with the specific application planned by the customer. In particular, that the mechanical resistance is adequate to withstand the foreseeable stresses during use, e.g. in case of accidental impacts or ejection of materials. The product is intended for use in a dry environment, protected from atmospheric agents.

**PROTEC Srl**

36100 VICENZA – ITALY  
Via Zamenhof, 363  
Tel. +39 0444 246080  
Fax +39 0444 240251  
Info.protec@grupposicura.it  
PI. C.F. e N° Reg. Impr. di Vicenza: 02572680243

**5. ADDITIONAL TECHNICAL FEATURES**

The NOVATEK panel is produced from a profile for 11A frames and with a central crosspiece in 15x15 tube, while the infill is made of a rectangular 32x67 wire Ø3mm net.

The ECOTEK panel is built from a 10x25 profile and with a central crosspiece in 10x10 pipe, while the infill is made of a rectangular 32x67 wire Ø3mm net.

The TECHNO Ø3 panel is built from a sheet of 32x67 wire Ø3mm net stiffened by n.3 horizontal ribs with the shape of an "omega".

The TECHNO Ø4 panel is produced from a sheet of 32x67 wire Ø4mm net stiffened by means of n.3 horizontal ribs with the shape of an "omega".

The posts of the systems are in pre-drilled 40x40 or 40x80 or 80x80 2 mm. thickness tubes.

It should also be remarked that any fragments generated within the segregated zone and thrown outwards, the dimensions of which are lower than those of the mesh light, can not be retained by the guards themselves.

It will be up to the customer to realize an adequate anchoring of the posts to the ground.

**6. USE OF THE GUARDS**

The doors (movable guards) present in the protection barriers systems are intended for the exclusive purpose of managing the regulated access in full safety to the segregated area.

This condition can be guaranteed by the presence of the safety microswitches on the doors that provide for the interruption of the dangerous functions within the area or alternative systems whose evaluation is the responsibility of the customer.

The correct use of the doors involves stopping the machine or its dangerous functions before opening it.

It is forbidden to stop the machine by opening the guard.

**7. PERIODIC MAINTENANCE**

Periodic maintenance interventions to be carried out on the guards are of mechanical and electrical nature; the execution of the same with frequent periodicity guarantees the maintenance of the expected level of security.

Mechanical interventions:

1. Periodic check of the correct tightening of the panel anchor screws
2. Periodic check of the correct tightening of the upright fixing systems to the ground
3. Check the welding points of the grid on the frame
4. Periodic check of the mechanical functioning of the door

Electrical interventions:

1. Periodic check of the correct operation of the microswitch when the door is opened.

**8. MINIMUM SAFETY REQUIREMENTS**

Incorrect and therefore prohibited uses are:

- Climb and climb over and in general evade the shelters;
- Hanging or fixing loads that could compromise the stability of the guards;
- Hang or secure electrical appliances without protection against indirect contact on the guards.
- Any tampering with the guards (e.g. cutting the net to create cracks, loosening the fixings, etc.) and the door interlocks.

Before carrying out operations not expressly provided for in this manual, contact the Protec srl technical office.

**PROTEC Srl**

36100 VICENZA – ITALY  
Via Zamenhof, 363  
Tel. +39 0444 246080  
Fax +39 0444 240251  
Info.protec@grupposicura.it  
PI. C.F. e N° Reg. Impr. di Vicenza: 02572680243

## CE KONFORMITÄTSERKLÄRUNG

Als gesetzlicher Vertreter von:

### PROTEC Srl

Via Zamenhof, 363  
36100 Vicenza Italy

Ich erkläre, dass das Abstandschutzsystem, bestehend aus festen, beweglichen und formschlüssigen modularen verdrahteten Paneele, bekannt als

## **NOVATEK, ECOTEK, TECHNO Ø3 - Ø4, (\*)**

erfüllt die spezifischen Anforderungen der Maschinenrichtlinie 2006/42/CE.  
erfüllt die spezifischen Anforderungen der Norm EN ISO 14120 und EN ISO 14119.

(\*) Siehe Liste der Bauelementen auf  
auf Seite 8 des folgenden NOVATEK-Systemhandbuchs  
auf Seite 9 des folgenden ECOTEK -Systemhandbuchs  
auf Seite 10 des folgenden TECHNO Ø3-Systemhandbuchs  
auf Seite 11 des folgenden TECHNO Ø4-Systemhandbuchs

Die zur Erstellung des technischen Blattes berechnete Person ist

### PROTEC Srl

Via Zamenhof, 363  
36100 Vicenza Italy

Vicenza, 01-01-2022

Der Chief Executive Officer

Michele Dalla Mora



### PROTEC Srl

36100 VICENZA – ITALY  
Via Zamenhof, 363  
Tel. +39 0444 246080  
Fax +39 0444 240251  
Info.protec@grupposicura.it  
PI. C.F. e N° Reg. Impr. di Vicenza: 02572680243



### 1. VERARBEITUNG UND BEWEGUNG

Die Schutzvorrichtungen müssen unter sicheren Bedingungen verarbeitet / angehoben werden, um einen angemessenen Schutz für alle beteiligten Personen zu gewährleisten, die keine schweren Lasten mit einem Gewicht von mehr als 25 kg verarbeiten / heben dürfen.

Schutzvorrichtungen mit einem Gewicht von mehr als 25 kg oder Paneele mit Abmessungen (d. H. Mit einer Breite von mehr als 1500 mm), die eine einfache Handhabung durch bestimmte Personen behindern, müssen mit speziellen Hebevorrichtungen angehoben und bewegt werden.

Protec empfiehlt die Verwendung eines vertikalen Hakens (z. B. Hebezeug, Brückenkran, ..) mit Haken, die im mittleren Abschnitt positioniert sind (wie in der Abbildung unten dargestellt).

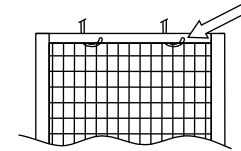

Protec rät von der Verwendung von Gabelstaplern oder anderen Hebevorrichtungen von unten ab, da dies keine angemessene Stabilität während der Bewegung garantiert.

### 2. MONTAGE (siehe Bedienungsanleitungen)

### 3. SYSTEM EINBAU

Abstandschützende NOVATEK, TECHNO Ø3-Ø4, ECOTEK-Paneelmodule müssen, soweit möglich, dem folgenden Referenzstandard entsprechen:

UNI EN 13857 Sicherheitsabstände des Zugangs zu Gefahrenbereichen durch die oberen und unteren äussersten Ende zu verhindern.

Paneele, die in Gefahrenbereichen positioniert werden, müssen die in der oben genannten Norm festgelegten Anforderungen mit Bezug auf die Höhe der einzelnen Paneele und Gefahrenbereiche, die Zugangsmassenbereiche und die Maschenabmessungen der verdrahteten Planeele erfüllen.

Bitte beachten Sie, dass die Einhaltung der Bestimmungen in der oben genannten Norm nicht zwingend ist; Wenn die Kunden unterschiedliche Lösungen anwenden, werden sie aufgefordert, im Falle einer Inspektion nachzuweisen, dass ihre installierte Option die gleichen Werte wie die oben genannten harmonisierten Normen garantiert.

PROTEC Srl, als exklusiver Hersteller der modularen verdrahteten Paneele, übernimmt keine Verantwortung für die Konfiguration der Abstandshalter, die ausschließlich die Verantwortung des Kunden ist.

Bitte beachten Sie, dass alle die Pfosten zu jeder Zeit am Boden befestigt werden müssen.

### 4. BESTIMMUNGSGEMÄßE VERWENDUNG

NOVATEK, TECHNO Ø3-Ø4, ECOTEK Modulare verdrahtete Paneele werden als Abstandschutz verwendet, um den Zugang zu als gefährlich definierten Bereichen um Maschinen herum zu verhindern oder zu reduzieren. Verdrahtete Platten werden in Übereinstimmung mit vernünftigerweise angenommenen externen Faktoren (d. H., Die außerhalb des Abstandsschutzes entstehen) und internen Faktoren (d. H. Ausgestoßenen Teilen, die von Materialien stammen, die verarbeitet werden, oder von der Maschine selbst entworfen) ausgelegt.

Detaillierte Abmessungen finden Sie im Bedienungsanleitungshandbuch.

Der Kunde muss sich vergewissern, dass die Eigenschaften der NOVATEK-, TECHNO-Ø3-Ø4- und ECOTEK-Produkte mit der vom Kunden vorgesehenen spezifischen Anwendung zusammenpassen.

Insbesondere muss die mechanische Festigkeit ausreichen, um den vorhersehbaren Belastungen während des Gebrauchs standzuhalten, z. B. bei unbeabsichtigten Stößen oder dem Herausspringen von Materialien.

Das Produkt ist zur Verwendung in einer trockenen und vor Witterungseinflüssen geschützten Umgebung vorgesehen.

### PROTEC Srl

36100 VICENZA – ITALY  
Via Zamenhof, 363  
Tel. +39 0444 246080  
Fax +39 0444 240251  
Info.protec@grupposicura.it  
PI. C.F. e N° Reg. Impr. di Vicenza: 02572680243





## 5. ZUSÄTZLICHE TECHNISCHE SPEZIFIKATIONEN

NOVATEK modulare verdrahtete Paneele werden mit einem 11A Profil für Fenster- und Torrahmen, einem zentralen Strahl in 15x15mm Schläuche und 32x67mm rechteckigem Ineinandergreifenfüllen, gebildet von 3mm Draht hergestellt.

ECOTEK modulare verdrahtete Paneele werden mit einem 10x25 Profil einem zentralen Strahl in 10x10mm Schläuche und 32x67mm rechteckigem Ineinandergreifenfüllen, gebildet von 3mm Draht hergestellt.

TECHNO Paneel ø3 besteht aus einem 32x67-Draht-Netz mit ø3 mm, der durch drei horizontale Rippen in Form eines "Omega" versteift ist.

TECHNO Paneel ø4 besteht aus einem 32x67-Draht ø4mm-Netz, der mit n.3 horizontalen Rippen in Form eines "Omega" versteift ist.

Die Pfosten der Systeme sind 40x40, 40x80 oder 80x80 2mm Dicke mit vorgebohrten Rohren.

Es sollte auch angemerkt werden, dass irgendwelche Fragmente, die innerhalb der abgesonderten Zone erzeugt werden und nach außen ausgeworfen werden, deren Abmessungen niedriger sind als diejenigen des Lichtes des Gitters, nicht von den Schutzvorrichtungen selbst zurückgehalten werden können.

Es ist Sache des Kunden, eine ausreichende Verankerung der Pfosten am Boden zu realisieren.

## 6. NUTZUNG DER SCHUTZZÄUNE

Das Tor (bewegliche trennende Schutzeinrichtung), das mit den trennenden Schutzeinrichtungen versehen ist, muss nur einen geregelten Zugang zu dem spezifischen gefährlichen Bereich unter sicheren Bedingungen ermöglichen.

Dieser Zustand kann durch das Vorhandensein von Sicherheitsmikroschaltern an den Türen gewährleistet werden, die für die Unterbrechung der gefährlichen Funktionen innerhalb des Bereichs oder alternativer Systeme sorgen, deren Bewertung in der Verantwortung des Kunden liegt.

Die korrekte Verwendung des Tors erfordert, dass Maschinen und gefährliche Funktionen gestoppt werden, bevor das Tor geöffnet wird.

Jegliche Verwendung von Toröffnungen zum Stoppen von Maschinen ist strengstens untersagt.

## 7. REGELMÄSSIGE WARTUNG

Eine periodische Wartung ist sowohl für die mechanischen als auch die elektrischen Funktionen der Barrieren erforderlich. Die regelmäßige Wartung beider Funktionen garantiert die geplanten Sicherheitsstufen.

Mechanische Wartungsarbeiten:

1. Periodische Überprüfung, ob alle Verankerungsschrauben korrekt auf den Paneelen befestigt sind
2. Regelmäßige Überprüfung des korrekten Festziehens der aufrechten Befestigungssysteme am Boden
3. Überprüfen Sie alle Punkte, an denen der Zaun an den Rahmen geschweißt wurde
4. Periodische Überprüfung der mechanischen Funktionen des Tores

Elektrische Wartungsarbeiten:

1. Periodische Überprüfung, ob der Sicherheitsschalter beim Öffnen des Tors korrekt funktioniert.

## 8. MINDEST SICHERHEITSANFORDERUNGEN

Falsche und daher verbotene Verwendungen sind:

- Klettern und überklettern und im Allgemeinen, den Unterständen ausweichen.
- Aufhängung oder Befestigung von Lasten, die die Stabilität der Schutzvorrichtungen beeinträchtigen könnten.
- Elektrogeräte hängen oder sichern, ohne Schutz gegen indirektes Berühren der Schutzvorrichtungen.
- Eingriffe in die Schutzvorrichtungen (z. B. Schneiden des Netzes, um Risse zu erzeugen, Lösen der Befestigungen usw.) und die Türverriegelung.

Wenden Sie sich an das technische Büro von Protec srl, bevor Sie Arbeiten ausführen, die in diesem

PROTEC Srl

36100 VICENZA – ITALY

Via Zamenhof, 363

Tel. +39 0444 246080

Fax +39 0444 240251

Info.protec@grupposicura.it

PI. C.F. e N° Reg. Impr. di Vicenza: 02572680243



## DÉCLARATION DE CONFORMITÉ CE

En tant que représentant légal de:

**PROTEC Srl**

Via Zamenhof, 363

36100 Vicenza Italy

Je déclare que le système de protection à distance, composé par panneaux fixes, mobiles et de verrouillage modulaire, appelé

## **NOVATEK, TECHNO ø3-ø4, ECOTEK (\*)**

sont conformes aux exigences spécifiques de la "Directive de Machines" 2006/42/CE.

sont conformes aux exigences spécifiques de la Norme EN ISO 14120 et EN ISO 14119.

(\*) Voir la liste des composants :

à la page 8 du manuel du système NOVATEK suivant

à la page 9 du manuel du système ECOTEK suivant

à la page 10 du manuel du système TECHNO ø3 suivant

à la page 11 du manuel du système TECHNO ø4 suivant

La personne autorisée à établir la fiche technique est:

**PROTEC Srl**

Via Zamenhof, 363

36100 Vicenza Italy

Vicenza, 01-01-2022

Le chef de la direction

Michele Dalla Mora

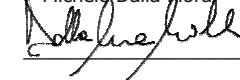

PROTEC Srl

36100 VICENZA – ITALY

Via Zamenhof, 363

Tel. +39 0444 246080

Fax +39 0444 240251

Info.protec@grupposicura.it

PI. C.F. e N° Reg. Impr. di Vicenza: 02572680243



### 1. MANIPULATION ET MOUVEMENT

Les protections doivent obligatoirement être manipulées / levées dans des conditions de sécurité, afin d'assurer une protection adéquate à toutes les personnes impliquées, qui ne doivent pas manipuler / soulever des poids supérieurs à 25 kg.

Les gardes qui pèsent plus de 25 kg, ou les panneaux caractérisés par des dimensions (c'est-à-dire une largeur supérieure à 1500 mm) empêchant une manipulation aisée par des personnes préposés, doivent être soulevés et déplacés avec un équipement de levage spécial.

Protec recommande d'utiliser un crochet vertical (par exemple un appareil de levage, un pont roulant, etc.), avec des crochets placés dans la section centrale (comme illustré sur la figure ci-dessous).

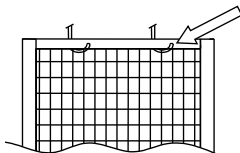

Protec déconseille l'utilisation de chariots élévateurs à fourche ou d'autres moyens de levage par le bas, car cela ne garantit pas une stabilité raisonnable pendant le mouvement.

### 2. ASSEMBLAGE (voir le "manuel d'instruction")

### 3. INSTALLATION DU SYSTÈME

Les barrières d'épandage périmétriques réalisées avec les protections NOVATEK, TECHNO Ø3-Ø4, ECOTEK doivent être conformes aux normes de référence suivantes:

UNI EN 13857: Distances de sécurité pour empêcher l'atteinte des zones dangereuses avec les membres supérieurs et inférieurs.

Le positionnement des panneaux dans les zones dangereuses doit respecter les stipulations de la norme précitée, en termes de hauteur des panneaux individuels et des zones dangereuses, en ce qui concerne les zones d'accès au sol et les dimensions des mailles des panneaux câblés.

Veillez noter que le respect des stipulations, énoncées dans la norme susmentionnée, n'est pas obligatoire; Si les clients mettent en œuvre des solutions différentes, ils seront appelés à démontrer, en cas d'inspection, que leur option installée garantit les mêmes niveaux que les normes harmonisées susmentionnées.

PROTEC Srl, en tant que fabricant exclusif des panneaux câblés modulaires, n'acceptera aucune responsabilité pour la configuration des protecteurs à distance, qui est de la responsabilité exclusive du client.

Nous vous rappelons l'obligation imperative, de fixer les poteaux au sol.

### 4. DESTINATION D'UTILISATION

Les panneaux modulaires NOVATEK, TECHNO Ø3-Ø4, ECOTEK sont utilisés comme protecteurs à distance afin d'empêcher ou de réduire l'accès aux zones, définies comme dangereuses, autour des machineries. Les panneaux câblés sont conçus en fonction de facteurs externes raisonnablement supposés (c'est-à-dire provenant de l'extérieur du protecteur de distance) et de facteurs internes (c'est-à-dire des pièces éjectées provenant des matériaux traités ou de la machine elle-même). Pour les dimensions détaillées, voir le Manuel d'instructions.

Le client doit vérifier que les caractéristiques des produits NOVATEK, TECHNO Ø3-Ø4, ECOTEK sont compatibles avec l'application spécifique prévue par le client. En particulier, que la résistance mécanique soit suffisante pour supporter les contraintes prévisibles pendant l'utilisation, par exemple en cas de chocs accidentels ou de saillie des matériaux.

Le produit est destiné à être utilisé dans un environnement sec et protégé des agents atmosphériques.

#### PROTEC Srl

36100 VICENZA – ITALY  
Via Zamenhof, 363  
Tel. +39 0444 246080  
Fax +39 0444 240251  
Info.protec@grupposicura.it  
P.I. C.F. e N° Reg. Impr. di Vicenza: 02572680243



### 5. SPÉCIFICATIONS TECHNIQUES SUPPLÉMENTAIRES

Le panneau NOVATEK est construit à partir d'un profil pour les portes et fenêtres 11A et avec la traverse centrale dans le tube de 15x15, tandis que l'élément de remplissage se trouve dans le réseau de fil rectangulaire 32x67 Ø3mm.

Le panneau ECOTEK est construit à partir d'un profilé 10x25 et d'une traverse centrale en tube de 10x10, tandis que le remplissage est fait d'un filet rectangulaire Ø3mm de 32x67 mm.

Le panneau TECHNO Ø3 est fabriqué à partir d'une plaque de treillis métallique de 32x67 mm raidie de n3 nervures horizontales en forme de "oméga".

Le panneau TECHNO Ø4 est construit à partir d'une plaque de treillis métallique de Ø4mm de 32x67 raidie par n.3 nervures horizontales en forme de "oméga".

Les montants des systèmes sont en tubes pré-perçés de 40x40 ou 40x80 ou 80x80 sp.2mm.

Il convient également de noter que les éventuels fragments générés à l'intérieur de la zone ségréguée et projetés vers l'extérieur, dont les dimensions sont inférieures à celles de la lumière maillée, ne peuvent pas être conservés par les gardes eux-mêmes.

Il appartiendra au client de réaliser un ancrage adéquat des poteaux au sol.

### 6. UTILISATION DES GARDES

Les portes (protections mobiles) présentes dans les systèmes de barrières d'éloignement sont destinées exclusivement à la gestion de l'accès réglementé en toute sécurité à la zone de ségrégation.

Cette condition peut être garantie par la présence de micro-interrupteurs de sécurité sur les portes qui prévoient l'interruption des fonctions dangereuses dans la zone ou des systèmes alternatifs dont l'évaluation est à la charge du client.

L'utilisation correcte des portes implique l'arrêt de la machine ou de ses fonctions dangereuses avant de l'ouvrir.

Il est interdit d'arrêter la machine en ouvrant la garde.

### 7. ENTRETIEN PÉRIODIQUE

Les interventions d'entretien périodique à effectuer sur les protections sont de nature mécanique et électrique; l'exécution de celui-ci avec périodicité fréquente garantit le maintien du niveau de sécurité attendu.

Interventions mécanique

1. Vérification périodique du bon serrage des vis d'ancrage du panneau
2. Contrôle périodique du bon serrage des poteaux au sol
3. Vérification des points de soudure du réseau sur le cadre
4. Vérification périodique du fonctionnement mécanique de la porte

Interventions électriques

1. Vérification périodique du bon fonctionnement du micro-interrupteur pour l'ouverture de la porte.

### 8. CONDITIONS MINIMALES DE SÉCURITÉ

Les utilisations incorrectes et donc interdites sont:

- grimper et échapper généralement les protections;
- suspendre ou fixer des charges qui pourraient compromettre la stabilité des protections;
- accrocher ou sécuriser les appareils électriques sans protection contre les contacts indirects avec les protections.
- Toutes altération des protections (par exemple, couper le treillis pour créer des fissures, desserrer les fixations, etc.) et des verrouillages des portes.
- Avant d'effectuer des opérations non expressément prévues dans ce manuel, contactez le bureau

#### PROTEC Srl

36100 VICENZA – ITALY  
Via Zamenhof, 363  
Tel. +39 0444 246080  
Fax +39 0444 240251  
Info.protec@grupposicura.it  
P.I. C.F. e N° Reg. Impr. di Vicenza: 02572680243



## DECLARACIÓN DE CONFORMIDAD CE

El firmante, representante legal de la :

**PROTEC Srl**  
Via Zamenhof, 363  
36100 Vicenza Italy

declara que el sistema de barreras de protección, consistente en paneles modulares fijos y móviles

### NOVATEK, ECOTEK, TECHNO Ø3-Ø4, (\*)

cumplen con los requisitos aplicables de la "Directiva de maquinarias" 2006/42/CE.  
cumplen con los requisitos aplicables de la Norma EN ISO 14120 y EN ISO 14119.

(\*) Consulte la lista de componentes a los que :  
en la página 8 del siguiente manual el sistema NOVATEK  
en la página 9 del siguiente manual el sistema ECOTEK  
en la página 10 del siguiente manual el sistema TECHNO Ø3  
en la página 11 del siguiente manual el sistema TECHNO Ø4

La persona autorizada para la constitución del expediente técnico es:

**PROTEC Srl**  
Via Zamenhof, 363  
36100 Vicenza Italy

Vicenza, 01-01-2022

*El Consejero Delegado*  
Michele Dalla Mora

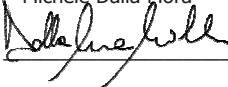

**PROTEC Srl**  
36100 VICENZA - ITALY  
Via Zamenhof, 363  
Tel. +39 0444 246080  
Fax +39 0444 240251  
Info.protec@grupposicura.it  
P.I. C.F. e N° Reg. Impr. di Vicenza: 02572680243



### 1. MANIPULACIÓN Y MOVIMIENTO

Tenga en cuenta que el manejo / levantamiento de las protecciones debe realizarse en condiciones de total seguridad y sin consecuencias físicas significativas para una sola persona, hasta un peso que no exceda los 25 kg.

Las protecciones que pesen más de 25 kg o de dimensiones tales que no permitan su fácil manipulación por una sola persona (ancho no superior a 1500 mm), deberán levantarse y moverse con el equipo de elevación.

Protec recomienda usar un dispositivo con un gancho desde la parte superior (por ejemplo, poleas, grúa puente ...) aplicando el gancho en el área central como se muestra en el siguiente dibujo:

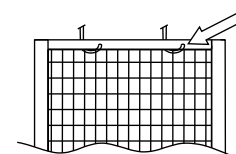

Protec no recomienda el uso de carretillas elevadoras u otros dispositivos de elevación desde abajo, ya que no es posible garantizar una estabilidad razonable durante el movimiento.

### 2. MONTAJE (ver manual de instrucciones)

### 3. INSTALACIÓN DEL SISTEMA

Las barreras perimetrales fabricadas con las protecciones NOVATEK, TECHNO Ø3-Ø4, ECOTEK deben cumplir con los siguientes estándares de referencia:

UNI EN 13857 Distancias de seguridad para evitar la entrada en áreas peligrosas con las extremidades superiores e inferiores.

La colocación de las protecciones con respecto a las zonas de peligro ha de cumplir con las medidas previstas por la norma mencionada, de acuerdo con la altura de los paneles individuales, la altura de los centros de peligro con respecto al área transitable y las dimensiones de la red.

Se hace hincapié en que el cumplimiento de las medidas previstas por el reglamento mencionado no es vinculante; sin embargo, si el usuario decide elegir una solución diferente, puede ser llamado a verificar que los métodos de instalación garanticen el mismo nivel de seguridad que las normas armonizadas.

PROTEC Srl como único fabricante de las protecciones no asumirá en ningún caso, la responsabilidad de la configuración del sistema de barreras que recaerá exclusivamente en el usuario.

Finalmente, se recuerda la obligación de fijar los postes al suelo.

### 4. USO

Las barreras del sistema NOVATEK, TECHNO Ø3 - Ø4, ECOTEK están diseñadas como barreras perimetrales para zonas de máquinas con puntos de peligro. Se han dimensionado en relación a los esfuerzos razonablemente previsibles zonas externas a la protección y las internas generadas por la posible separación de las piezas que se mecanizan y / o piezas de la máquina.

Para conocer las características dimensionales, consulte el "Manual de instrucción".

El cliente debe comprobar que las características de los productos NOVATEK, TECHNO Ø3-Ø4, ECOTEK son compatibles con la aplicación específica prevista por el cliente. En particular, que la resistencia mecánica sea suficiente para soportar las tensiones previsibles durante el uso, por ejemplo, en el caso de impactos accidentales o desprendimiento de materiales. El producto está diseñado para su uso en un ambiente seco y protegido de agentes atmosféricos.

**PROTEC Srl**  
36100 VICENZA - ITALY  
Via Zamenhof, 363  
Tel. +39 0444 246080  
Fax +39 0444 240251  
Info.protec@grupposicura.it  
P.I. C.F. e N° Reg. Impr. di Vicenza: 02572680243



## 5. ESPECIFICACIONES TÉCNICAS ADICIONALES

El panel NOVATEK se construye a partir de un perfil para marcos 11A y con un travesaño central en un tubo de 15x15, mientras que el relleno está hecho de una malla rectangular de 32x67 hilos ø3 mm.

El panel ECOTEK se construye a partir de un perfil de 10x25 y con un travesaño central en un tubo de 10x10, mientras que el relleno está hecho de una malla rectangular de 32x67 hilos ø3 mm.

El panel TECHNO ø3 está construido a partir de una hoja de malla de 32x67 hilos ø3mm endurecida por n. 3 pliegues horizontales en forma de "omega".

El panel TECHNO ø4 está construido a partir de una lámina de malla de 32x67 hilos ø4mm endurecida mediante n.3 varillas horizontales en forma de "omega".

Los montantes de los sistemas están en tubos pretaladrados de 40x40 o 40x80 o 80x80 de 2 mm. de grosor

También debe tenerse en cuenta que los fragmentos generados dentro de la zona segregada y lanzados hacia el exterior, cuyas dimensiones son más bajas que las de la luz de la malla, no pueden ser retenidos por las propias protecciones.

Corresponderá al cliente realizar un anclaje adecuado de los postes al suelo.

## 6. USO DE LAS PROTECCIONES

Las puertas (protecciones móviles) presentes en los sistemas de barreras de distanciamiento están destinadas con el exclusivo propósito de gestionar el acceso regulado con total seguridad a la zona segregada.

Esta condición puede garantizarse mediante la presencia de microinterruptores de seguridad en las puertas que prevén la interrupción de las funciones peligrosas dentro del área o sistemas alternativos cuya evaluación es responsabilidad del cliente.

El uso correcto de las puertas implica detener la máquina o sus funciones peligrosas antes de abrirla.

Está prohibido detener la máquina a través de la apertura de la protección.

## 7. MANTENIMIENTO PERIODICO

Las intervenciones periódicas de mantenimiento que se llevarán a cabo en las protecciones son de naturaleza mecánica y eléctrica; la ejecución de las mismas con periodicidad frecuente garantiza el mantenimiento del nivel de seguridad esperado.

Intervenciones mecánicas:

1. Comprobación periódica de la correcta fijación de los tornillos de anclaje del panel
2. Comprobación periódica del correcto ajuste de los sistemas de fijación vertical al suelo.
3. Comprobación de los puntos de soldadura de la red en el marco
4. Comprobación periódica de funcionamiento mecánico de la puerta

Intervenciones eléctricas:

1. Comprobación periódica del correcto funcionamiento del microinterruptor cuando se abre la puerta.

## 8. REQUISITOS MÍNIMOS DE SEGURIDAD

Los usos incorrectos y por lo tanto prohibidos son:

- Subir y trepar y en general evadir las protecciones;
- Colgar o fijar cargas que podrían comprometer la estabilidad de las protecciones;
- Colgar o asegurar los aparatos eléctricos sin protección contra el contacto indirecto en los paneles.
- Cualquier manipulación de los paneles (por ejemplo, cortar la malla para crear grietas, aflojar las fijaciones, etc.) y los enclavamientos de la puerta.
- Antes de realizar operaciones no previstas expresamente en este manual, póngase en contacto con la

PROTEC Srl

36100 VICENZA – ITALY

Via Zamenhof, 363

Tel. +39 0444 246080

Fax +39 0444 240251

Info.protec@grupposicura.it

Pl. C.F. e N° Reg. Impr. di Vicenza: 02572680243

**SICURA**



[www.protec-italy.net](http://www.protec-italy.net)



Manuale istruzioni - rev4  
Gennaio 2022  
© Copyright 2022 Protec