

BK系列 (方形固定側) Support Unit BK (fixed-side rectangular type)

訂購編號 Order Coding	型號 Model No.	表面處理 Surface treatment	適用螺桿 Applicable boltscrew accuracy grade	使用軸承 Bearing
BK10_C7	BK10	染黑 Black Oxide	C7	7000A P0
BK10_C5			C5	
BK10_C3			C3	7000A P5
BK10_C7N		化學鍍 Electroless Nickel Plating	C7	7000A P0
BK10_C5N			C5	
BK10_C3N			C3	7000A P5
BK12_C7	BK12	染黑 Black Oxide	C7	7001A P0
BK12_C5			C5	
BK12_C3			C3	7001A P5
BK12_C7N		化學鍍 Electroless Nickel Plating	C7	7001A P0
BK12_C5N			C5	
BK12_C3N			C3	7001A P5
BK15_C7	BK15	染黑 Black Oxide	C7	7002A P0
BK15_C5			C5	
BK15_C3			C3	7002A P5
BK15_C7N		化學鍍 Electroless Nickel Plating	C7	7002A P0
BK15_C5N			C5	
BK15_C3N			C3	7002A P5
BK17_C7	BK17	染黑 Black Oxide	C7	7203A P0
BK17_C5			C5	
BK17_C3			C3	7203A P5
BK17_C7N		化學鍍 Electroless Nickel Plating	C7	7203A P0
BK17_C5N			C5	
BK17_C3N			C3	7203A P5
BK20_C7	BK20	染黑 Black Oxide	C7	7004A P0
BK20_C5			C5	
BK20_C3			C3	7004A P5
BK20_C7N		化學鍍 Electroless Nickel Plating	C7	7004A P0
BK20_C5N			C5	
BK20_C3N			C3	7004A P5



染黑 (適用環境: 一般)
Black Oxide (Application: General case)





化學鍍 (適用環境: 無塵室)
Electroless Nickel Plating (Application: Clean room)

備註 (Note)

- C7級使用之軸承無預壓處理, 軸向最大間隙0.018mm
(Bearings are no Preload for C7 type support units, and Max. Axial clearance is 0.018 mm.)
- C5級使用之軸承經預壓處理, 軸向 0間隙
(Bearings make Preload for C5 type support units, and Axial clearance is 0 mm.)
- 軸承皆採用日系品牌大廠
(All of bearings use Japan's brand bearings.)

BK系列 (方形固定側) Support Unit BK (fixed-side rectangular type)

訂購編號 Order Coding	型號 Model No.	表面處理 Surface Treatment	適用螺桿 Applicable ballscrew accuracy grade	使用軸承 Bearing	
BK25_C7	BK25	染黑 Black Oxide	C7	7205A P0	
BK25B_C7			C7	7205B P0	
BK25_C5			C5	7205A P0	
BK25B_C5			C5	7205B P0	
BK25_C3			C3	7205A P5	
BK25_C7N		化學鍊 Electroless Nickel Plating	C7	7205A P0	
BK25B_C7N			C7	7205B P0	
BK25_C5N			C5	7205A P0	
BK25B_C5N			C5	7205B P0	
BK25_C3N			C3	7205A P5	
BK30_C7	BK30	染黑 Black Oxide	C7	7206A P0	
BK30B_C7			C7	7206B P0	
BK30_C5			C5	7206A P0	
BK30B_C5			C5	7206B P0	
BK30_C3			C3	7206A P5	
BK30_C7N		化學鍊 Electroless Nickel Plating	C7	7206A P0	
BK30B_C7N			C7	7206B P0	
BK30_C5N			C5	7206A P0	
BK30B_C5N			C5	7206B P0	
BK30_C3N			C3	7206A P5	
BK35_C7	BK35	染黑 Black Oxide	C7	7207B P0	
BK35_C5			C5	7207B P0	
BK35_C3			C3	7207B P5	
BK35_C7N		化學鍊 Electroless Nickel Plating	C7	7207B P0	
BK35_C5N			C5	7207B P0	
BK35_C3N			C3	7207B P5	
BK40_C7	BK40	染黑 Black Oxide	C7	7208B P0	
BK40_C5			C5	7208B P0	
BK40_C3			C3	7208B P5	
BK40_C7N		化學鍊 Electroless Nickel Plating	C7	7208B P0	
BK40_C5N			C5	7208B P0	
BK40_C3N			C3	7208B P5	

染黑 (適用環境: 一般)
Black Oxide (Application: General case)

化學鍊 (適用環境: 無塵室)
Electroless Nickel Plating (Application: Clean room)

備註 (Note)

- C7級使用之軸承無預壓處理, 軸向最大間隙0.018mm
(Bearings are no Preload for C7 type support units, and Max. Axial clearance is 0.018 mm.)
- C5級使用之軸承經預壓處理, 軸向 0間隙
(Bearings make Preload for C5 type support units, and Axial clearance is 0 mm.)
- 軸承皆採用日系品牌大廠
(All of bearings use Japan's brand bearings.)

BK系列 (方形固定側)

Support Unit BK (fixed-side rectangular type)



番號/Part No.	部品名稱/Part name	數量/Qty
1	軸承座本體/Housing	1
2	軸承/Bearing	1組/1 set
3	壓板/Holding lid	1
4	間隔圈/Collar	2
5	軸封/Seal	2
6	鎖固螺帽/Lock nut	1組/1set
7	內六角止付螺絲附銅片 Hexagon socket-head Setscrew(with set piece)	2

BK

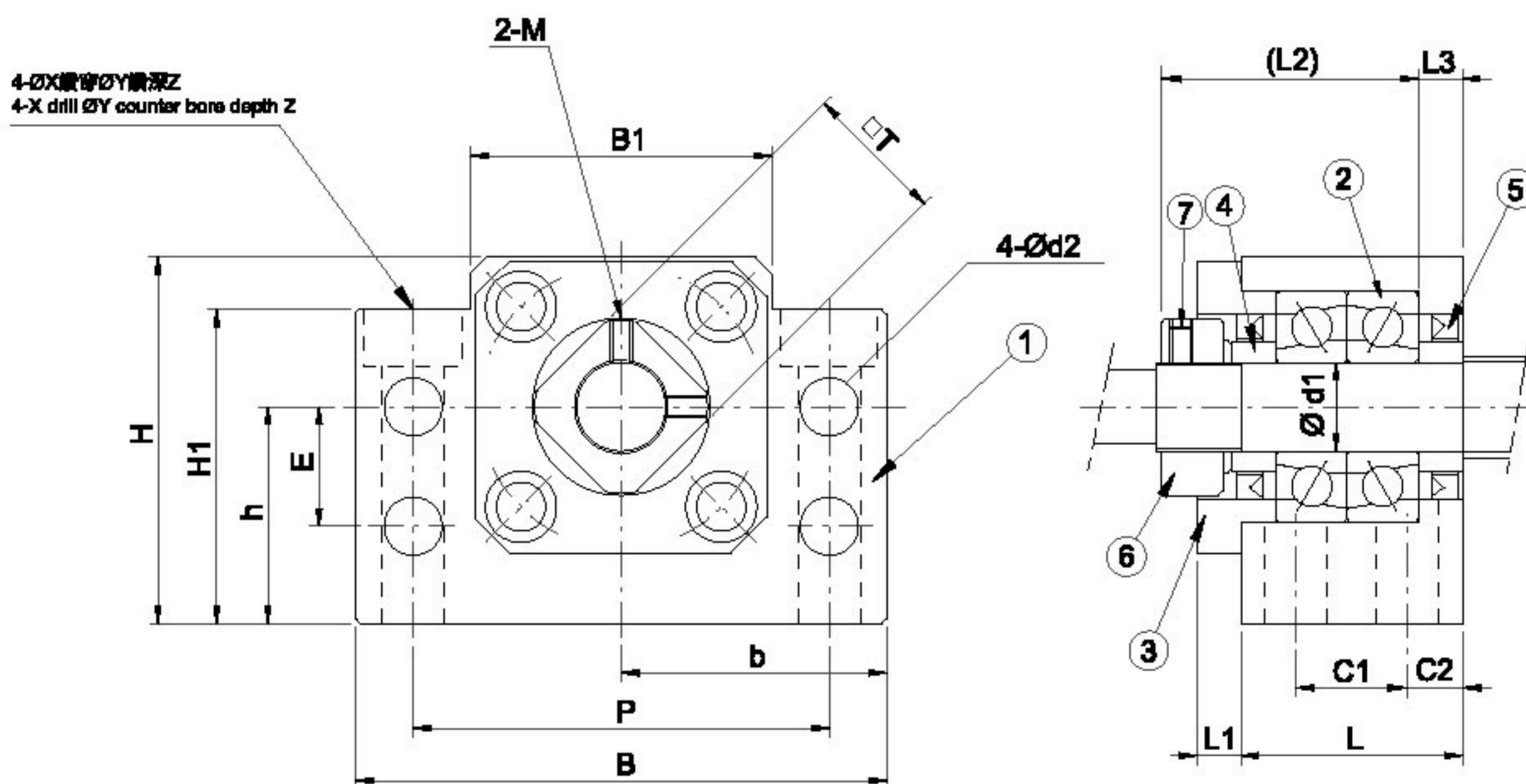

單位/Unit : mm

型號 Model No.	軸徑 Shaft diameter d1	L	L1	L2	L3	B	H	b	h	B1	H1	E	P	C1	C2	d2	X	Y	Z	M	T
								±0.02	±0.02												
BK10	10	25	5	29	5	60	39	30	22	34	32.5	15	46	13	6	5.5	6.6	10.8	5	M3	16
BK12	12	25	5	29	5	60	43	30	25	34	32.5	18	46	13	6	5.5	6.6	10.8	1.5	M4	19
BK15	15	27	6	32	6	70	48	35	28	40	38	18	54	15	6	5.5	6.6	11	6.5	M4	22
BK17	17	35	9	44	7	86	64	43	39	50	55	28	68	19	8	6.6	9	14	8.5	M4	24
BK20	20	35	8	43	8	88	60	44	34	52	50	22	70	19	8	6.6	9	14	8.5	M4	30
BK25	25	42	12	54	9	106	80	53	48	64	70	33	85	22	10	9	11	17.5	11	M5	35
BK30	30	45	14	61	9	128	89	64	51	76	78	33	102	23	11	11	14	20	13	M6	40
BK35	35	50	14	67	12	140	96	70	52	88	79	35	114	26	12	11	14	20	13	M8	50
BK40	40	61	18	76	15	160	110	80	60	100	90	37	130	33	14	14	18	26	17.5	M8	50