

440G-EZ Interlocking Safety Switch

Catalog Numbers 440G-EZS21STL05J, 440G-EZS21STL05H

Installation

Installation of the 440G-EZ Electromagnetic Guard Locking Safety Switch must be in accordance with the following steps and stated specifications and implemented by suitably competent personnel. The unit is not to be used as a mechanical stop. Guard stops and guides must be mounted.

Adherence to the recommended maintenance instructions forms part of the warranty.



ATTENTION: The presence of spare actuators can compromise the integrity of the safety systems. Personal injury or death, property damage, or economic loss can result. Appropriate management controls, working procedures, and alternative protective measures should be introduced to control their use and availability.



WARNING: Do not defeat, tamper, remove, or bypass this unit. Severe injury to personnel could result. This device must be provided with a 24V DC PELV or SELV power supply that conforms to the requirements of 414-3 of IEC 60364-4-41 where provisions have been taken. To confirm that, even if an internal fault, the voltage at the outgoing terminals cannot exceed 60V DC. Improper selection or installation of the devices affects the integrity of the safety systems.

Mount Multiple Safety Switches

IMPORTANT When several safety switches are mounted, the minimum distance between the individual systems must be followed to avoid mutual interference.

Figure 1 - Spacing Requirement [mm (in.)]

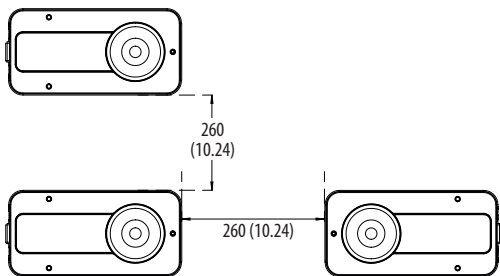

Mounting

The sensor can be mounted in the following ways:

- Surface mount — The sensor is mounted on the fixed part of the protective device (for example, door frame).
- Flush mount — The sensor is mounted in the fixed part of the protective device (for example, door frame). There must be a suitable recess in the mounting surface. The thickness of the mounting surface must be between 1.5...3 mm (0.06...0.12 in.)

For recess dimensions for flush mounting, see [Figure 4 on page 4](#).

IMPORTANT Install the safety switch horizontally to help increase protection against manipulation.

Mount the Sensor

1. Unscrew the fixing screw (hexagon socket, 2 mm [0.08 in.]) and remove the cover plate.

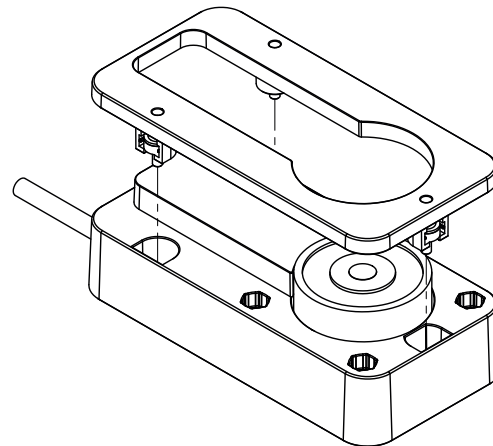

2. Mount the sensor on the fixed part of the protective device with 4 x M4 screws and secure it with four nuts.
 - For surface mount: mount the sensor on the fixed part of the protective device. The screws can be set in the front or the back.

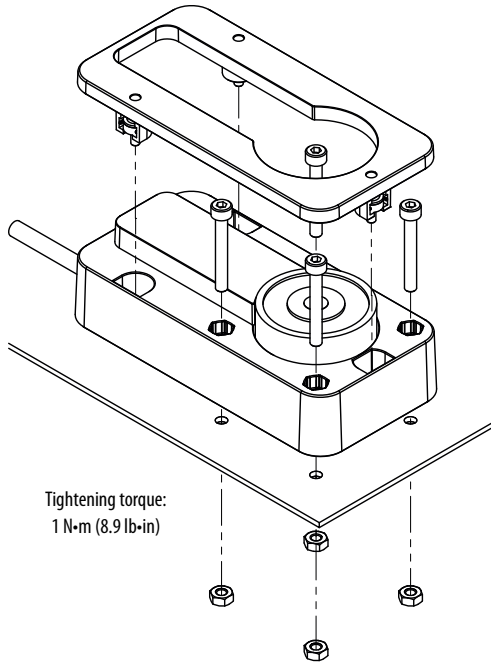

- For flush mount: mount the sensor in the fixed part of the protective device.

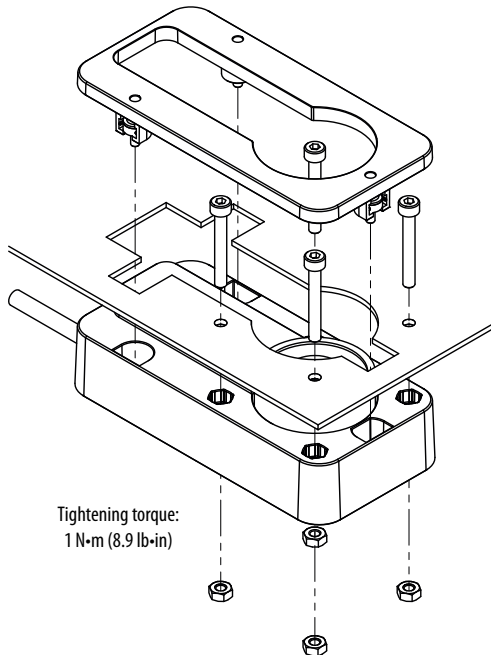

3. Set cover plate on the sensor.
4. Tighten the fixing screws to 1 N·m (8.9 lb·in).

Mount the Actuator

1. Align the actuator to the mounted sensor.
2. Mount the actuator on the moving part of the protective device (for example, door) with 4 x M4 screws. Tightening torque: 1 N·m (8.9 lb·in). Use disposable screws if possible.
 - Maximum angle between sensor and actuator when protective device is closed is 3°

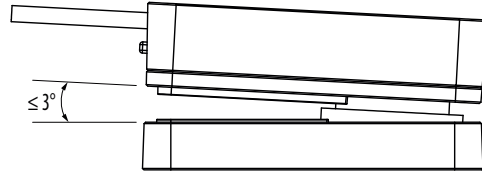

3. Cover drill holes of the actuator with protective caps.

Wiring

Figure 2 - Device Connection Pin Assignment (Male Connector, M12, 5-pin, A-coded)

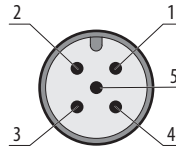

Pin	Wire Color ⁽¹⁾	Designation	Description
1	Brown	+24V DC	Safety switch voltage supply
2	White	OSSD 1	Safety output
3	Blue	0V	0V DC voltage supply
4	Black	OSSD 2	Safety output
5	Gray	Magnet	Magnet activation 24V DC

(1) Applies to the extension cables recommended as accessories.

IMPORTANT Pay attention to tightness of the plug connector.

Figure 3 - Device Connection Pin Assignment (Male Connector, M12, 8-pin, A-coded)

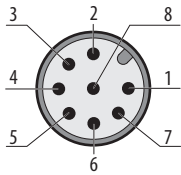

Pin	Wire Color ⁽¹⁾	Designation	Description
1	White	Aux	Application diagnostic output (not safe)
2	Brown	+24V DC	Safety switch voltage supply
3	Green	Magnet	Magnet activation 24V DC
4	Yellow	OSSD 2	Safety input ⁽²⁾
5	Gray	OSSD 1	Safety output
6	Pink	OSSD 2	Safety output
7	Blue	0V	0V DC voltage supply
8	Red	OSSD 1	Safety input ⁽²⁾

- (1) Applies to the extension cables recommended as accessories.
- (2) When used as an individual safety switch or as the first safety switch in a cascade apply 24V DC.

IMPORTANT Pay attention to tightness of the plug connector.

Status/Diagnostics Operating LED Indicators

The switch has two light-emitting diode (LED) indicators:

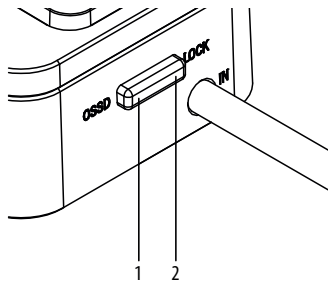

Item	Name	Color	Description
1	OSSD	Green/Red	Green when the OSSD pair is in the ON state. Red when the OSSD pair is in the OFF state. ⁽¹⁾
2	LOCK	Yellow	Turns ON when the magnet is supplied with voltage.

- (1) When a load is applied to the application diagnostic output that is too high, the red OSSD status indicator remains continuously ON. The actual switching behavior of the safety switch is not affected.

Power to Lock	Door/Guard Status	Lock Command	OSSD Input ⁽¹⁾	Lock Status	LED Status	OSSD Status
Power on and lock command off	Open or closed	Off	Off or on	Unlocked	—	Off
Lock command on and door open	Open	On	Off or on	Unlocked	Yellow	Off
Lock command on and door closed	Closed	On	Off	Locked	Red	Off
Lock command on and door closed	Closed	On	On	Locked	Solid Green	On

- (1) OSSD Input only used with 8-pin version.

Maintenance

Every week, check the alignment of the actuator to the switch and the correct operation of the switching circuit. Also check for signs of abuse or interference. Inspect the switch casing and actuator for damage. Replace if needed.

At least every six months, isolate all power. Remove the lid and end cover. Inspect all terminals for tightness. Clean out any accumulation of fine dirt. Check for any sign of wear of damage, for instance, actuator wear, cam assembly wear, contact oxidation and replace if needed. Replace cover and tighten screws to specified settings. Reinstall the power and check for correct operation. Reapply tamper evident varnish or similar compound for mountings.

Repair

If there is any malfunction or damage, make no attempts at repair. Replace before machine operation is allowed.

IMPORTANT Do not dismantle the unit.

Specifications

Table 1 - Specifications

Attribute	440G-EZS21STL05J, 440G-EZS21STL05H
Functional Safety Data (Guard door sensing and lock monitoring)	1.5 x 10 ⁻⁸ at 40 °C (104 °F) and 1000 m (3280.8 ft) above sea level Mission time/PTI: 20 years
Operating Characteristics	
Safe switch on distance	4 mm (0.16 in.)
Typical switch on distance	15 mm (0.59 in.)
Safe switch off distance	45 mm (1.77 in.)
Holding force	500 N
Retaining force	25 N
Maximum actuation frequency	0.5 Hz
Alignment tolerance for locking device	• Vertical: 5 mm (0.2 in.) • Horizontal: 5 mm (0.2 in.)
Aperture angle	3°
Offset tolerance	5 mm (0.2 in.)
Rated voltage	24V DC
Insulation voltage U _i	32V
Rated impulse withstand voltage U _{imp}	1.5 kV
Supply voltage when an individual safety switch is connected	24V DC (19.2...28.8 V DC) Class 2 supply
Supply voltage UV when a cascade is connected	• Sensor: 24V DC (22.8...28.8 V DC) Class 2 supply • Magnet: 24V DC (21.6...28.8 V DC) Class 2 supply
Power consumption	• Locking active: 350 mA • Locking deactivated: 50 mA
Switching frequency	≤0.5 Hz
Type of output	OSSD
Maximum Output current	≤100 mA
Diagnostic output	≤25 mA, short-circuit protected
Cable capacitance	400 nF (for OUT A and OUT B)
Response time	50 ms
Enable time	100 ms
Risk time	100 ms
Power up delay	2.5 s
Muting time when supply voltage is interrupted	4 ms

Table 1 - Specifications

Attribute	440G-EZS21STL05J, 440G-EZS21STL05H
Environmental	
Operating temperature	-20...+55 °C (-4...+131 °F)
Storage temperature	-25...+70 °C (-13...+158 °F)
Relative humidity	50% at 70 °C (158 °F) (IEC 60947-5-2)
Enclosure ingress rating	IP67
EMC	IEC EMC: EN IEC 61326-3-1, EN IEC 60947-5-2, EN IEC 60947-5-3
Vibration resistance	1 mm/10...55 Hz (IEC 60068-2-6)
Shock resistance	30 g, 11 ms (IEC 60068-2-27)
Outputs	
Safety outputs	2 x OSSDs, 2 x PNP, max. 100 mA, short-circuit protected and overload-proof
Auxiliary output	25 mA max, short-circuit protected (resistive load)
Switching voltage	• ON State: 19.2...28.8 V DC • OFF State: 0...2 V DC
Switching current	• ON State: ≤100 mA • OFF State: ≤500 µA
Test pulse duration	300 µs
Weight	
Sensor	510 g (18 oz)
Actuator	210 g (7.4 oz)
Material:	
Sensor housing	Anodized aluminum
Actuator housing	Fiber-glass-reinforced PVC
Anchor plate	Nickel-plated steel

Approximate Dimensions

Figure 4 - Flush Mounting [mm (in.)]

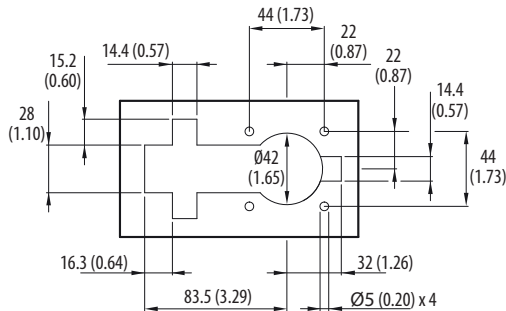

Figure 5 - Actuator [mm (in.)]

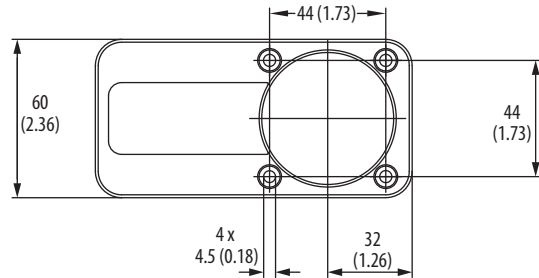
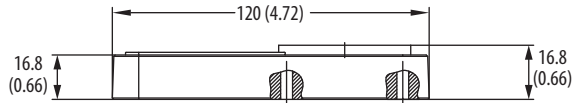
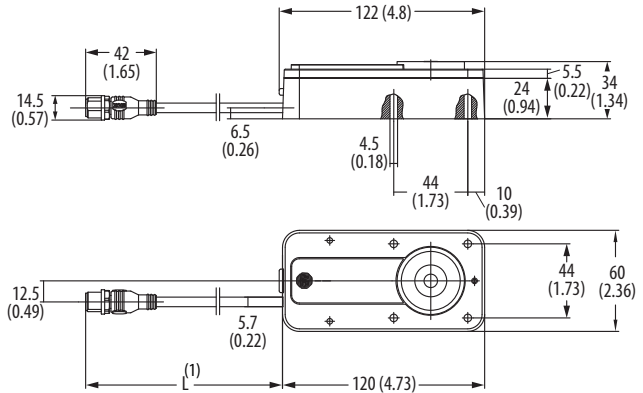

Figure 6 - Sensor [mm (in.)]



(1) L = 150±2 mm (5.91±0.79 in.)

Waste Electrical and Electronic Equipment (WEEE)



At the End of Life, this equipment should be collected separately from any unsorted municipal waste.

Rockwell Automation maintains current product environmental information on its website at <http://www.rockwellautomation.com/rockwellautomation/about-us/sustainability-ethics/product-environmental-compliance.page>.

Allen-Bradley, Rockwell Automation, and Rockwell Software are trademarks of Rockwell Automation, Inc. Trademarks not belonging to Rockwell Automation are property of their respective companies.

Rockwell Otomasyon Ticaret A.Ş., Kar Plaza İş Merkezi E Blok Kat:6 34752 İçerenköy, İstanbul, Tel: +90 (216) 5698400

www.rockwellautomation.com

Power, Control and Information Solutions Headquarters

Americas: Rockwell Automation, 1201 South Second Street, Milwaukee, WI 53204-2496 USA, Tel: (1) 414.382.2000, Fax: (1) 414.382.4444
 Europe/Middle East/Africa: Rockwell Automation NV, Pegasus Park, De Kleetlaan 12a, 1831 Diegem, Belgium, Tel: (32) 2 663 0600, Fax: (32) 2 663 0640
 Asia Pacific: Rockwell Automation, Level 14, Core F, Cyberport 3, 100 Cyberport Road, Hong Kong, Tel: (852) 2887 4788, Fax: (852) 2508 1846



PN-567593